

VERTI-COMB 1800 / 4000

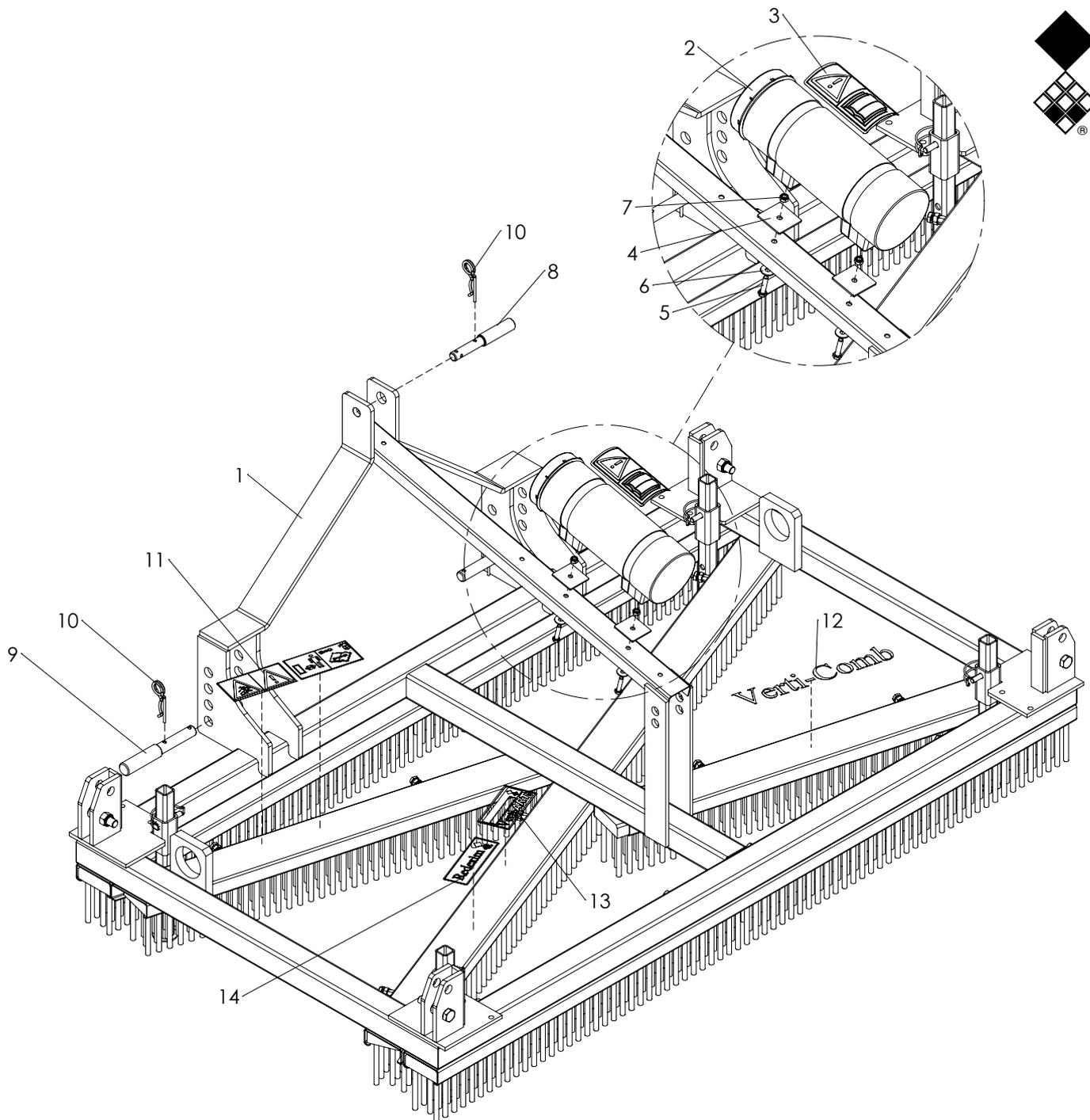

Version: 2201



ITEM	PART NUMBER	DESCRIPTION	REMARKS	QUA
1	494.108.180	Frame Verti-Comb 1800		1
2	444.803.100	Toolbox Complete		1
3	900.280.402	Safety decall manual		1
4	468.030.530	Toolbox contraplate		2
5	804.080.350	Bolt M8 x 35 - ISO 4017		2
6	864.080.024	Large washer M8 - DIN 9021		2
7	830.080.080	Self Lock Nut M8 - ISO 10511		2
8	521.191.600	Top link pin OS		1
9	414.281.950	3-Point Pin		2
10	523.051.000	R-clip Round 5, DIN 11024		3
11	933.280.402	Safety decal		1
12	942.260.404	Label Verti-Comb		1
13	947.260.200	Decall Verti-Art		1
14	900.260.403	Logo Label		1

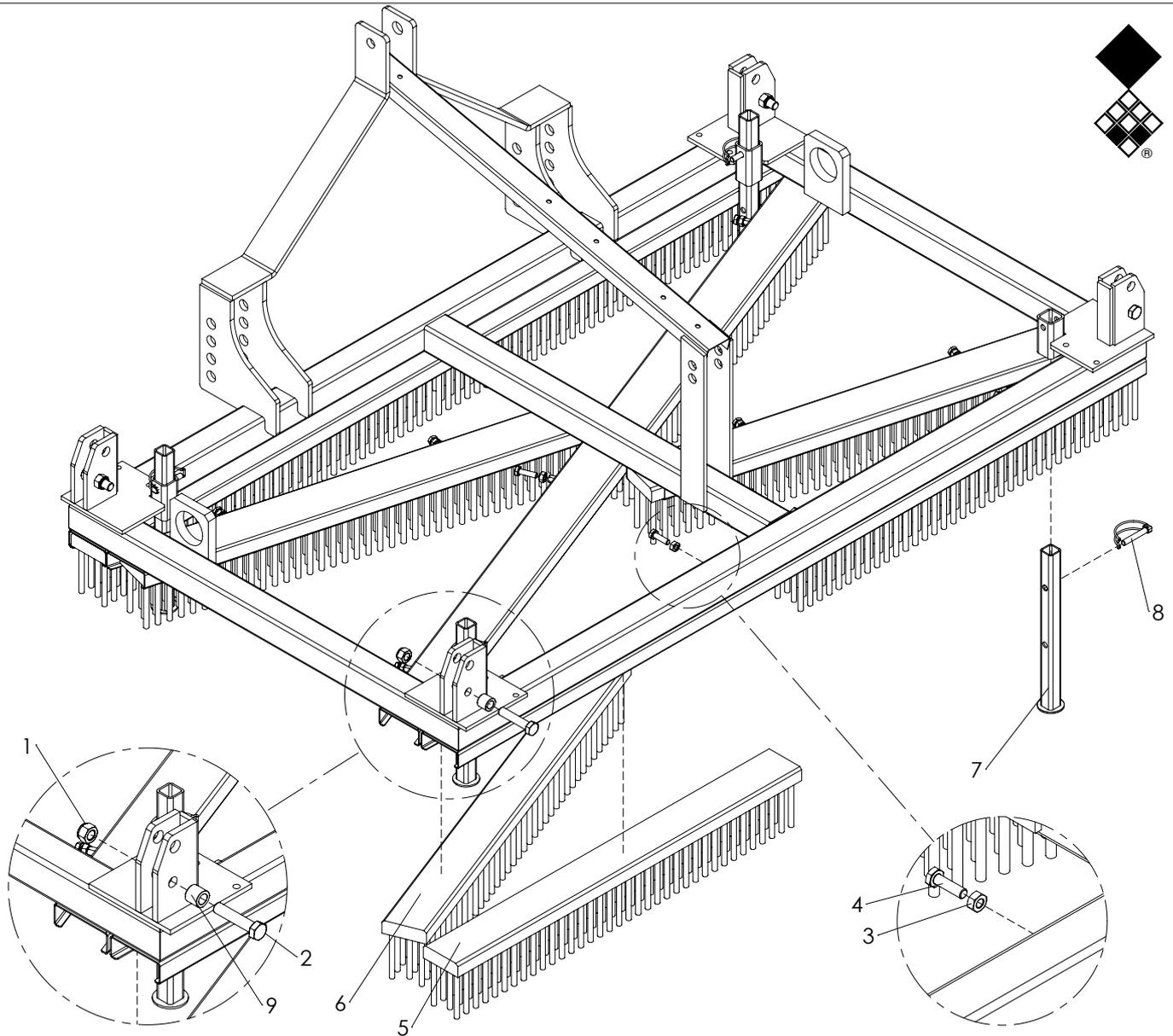

ITEM	PART NUMBER	DESCRIPTION	REMARKS	QUA
1	830.160.160	Self Lock Nut M16 10.9 - ISO 10511		4
2	802.160.750	Bolt M16 x 75 - ISO 4014		4
3	826.100.100	Nut M10 - DIN 934		16
4	804.100.350	Bolt M10 x 35 - ISO 4017		16
5	486.909.000	Brush hair thickness 2.2mm (0.09") L=900mm (35.4")	Color Yellow	4
	486.909.001	Brush hair thickness 1.5mm (0.06") L=900mm (35.4")	Color Dark Blue	4
	486.909.002	Brush hair thickness 3mm (0.12") L=900mm (35.4")	Color Light Blue	4
6	486.909.500	Brush hair thickness 2.2mm (0.09") L=950mm (37.4")	Color Yellow	4
	486.909.501	Brush hair thickness 1.5mm (0.06") L=950mm (37.4")	Color Dark Blue	4
	486.909.502	Brush hair thickness 3mm (0.12") L=950mm (37.4")	Color Light Blue	4
7	478.503.540	Jack		4
8	523.100.700	Pipe linch pin Ø10		4
9	406.160.174	Distance bush		4
	246.180.010	Set of brushes hair thickness 2.2mm (0.09")	Color Yellow, set of brushes for the Verti-Comb 1800.	
	246.180.008	Set of brushes hair thickness 1.5mm (0.06")	Color Yellow, set of brushes for the Verti-Comb 1800.	
	246.180.012	Set of brushes hair thickness 3mm (0.12")	Color Yellow, set of brushes for the Verti-Comb 1800.	

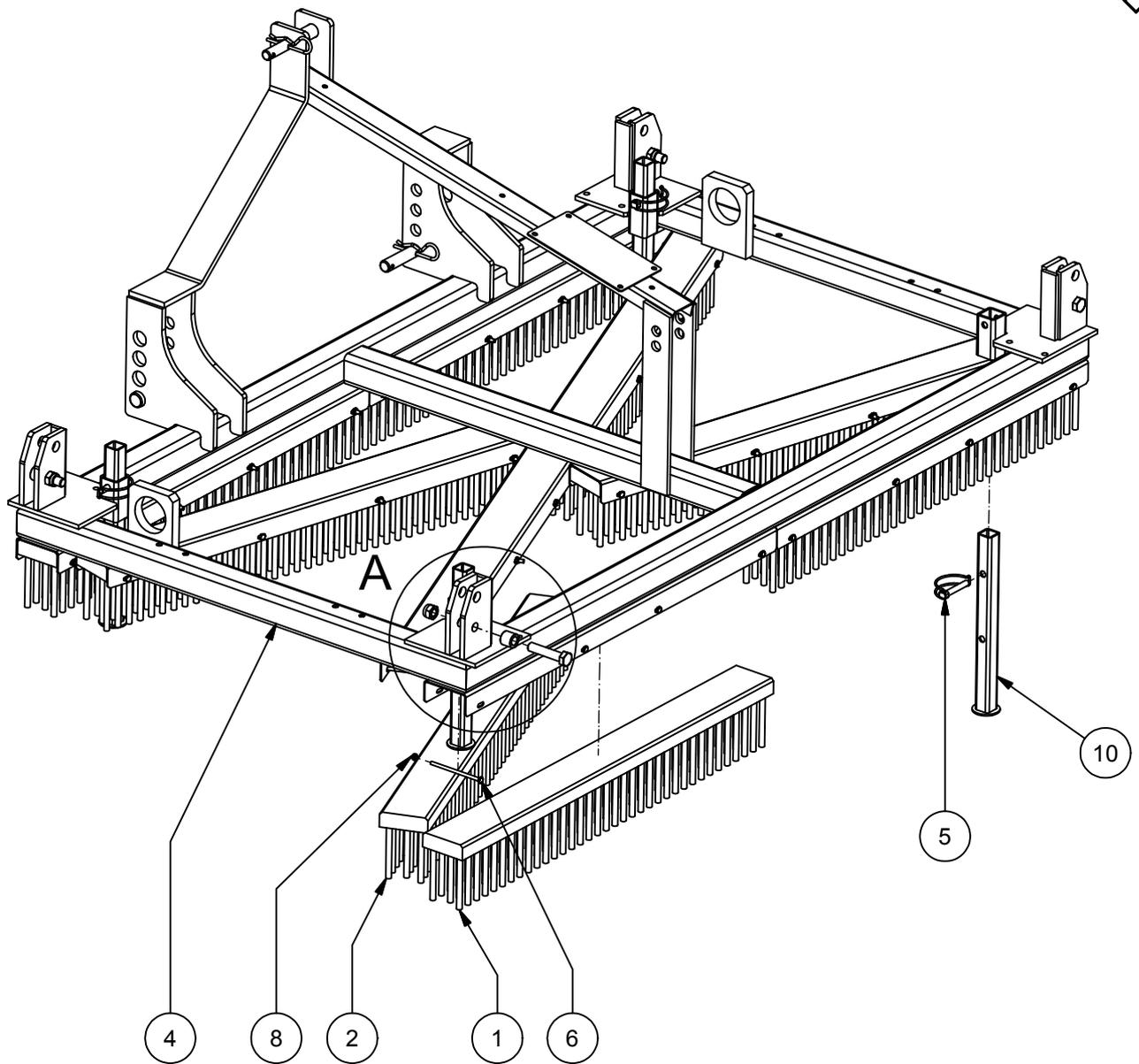

Detail A

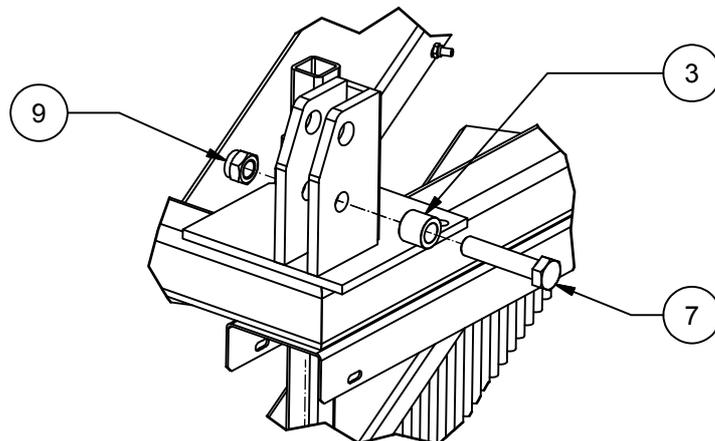

Redexim-Charterhouse Verti-Comb Pag 02 Code 1409

	PART #	DESCRIPTION	REMARKS	QUA
1	486.909.000	Brush Verti-Comb hair 2.2mm TL=900	Color yellow	4
	486.909.001	Brush Verti-Comb hair 1.5mm TL=900	Color dark blue	4
	486.909.002	Brush Verti-Comb hair 3mm TL=900	Color light blue	4
2	486.909.500	Brush Verti-Comb hair 2.2mm TL=950	Color yellow	4
	486.909.501	Brush Verti-Comb hair 1.5mm TL=950	Color dark blue	4
	486.909.502	Brush Verti-Comb hair 3mm TL=950	Color light blue	4
3	406.160.174	Distance bush		4
4	494.108.180	Base frame		1
5	523.100.700	Pipe linch pin		4
6	802.061.100	Bolt DIN 931-1 - M6 x 90		32
7	802.160.750	Bolt DIN 931-1 - M16 x 75		4
8	830.060.060	SL Nut DIN 985 - M6		32
9	830.160.160	SL Nut DIN 985 - M16		4
10	478.503.540	Jack		4
	246.180.010	Set of brushes VC1800 2.2mm	Color yellow Set of brushes for the VC 1800 version NOT the VC4000 -> See page 3	
	246.180.008	Set of brushes VC1800 1.5mm	Color dark blue Set of brushes for the VC 1800 version NOT the VC4000 -> See page 3	
	246.180.012	Set of brushes VC1800 3.0mm	Color light blue Set of brushes for the VC 1800 version NOT the VC4000 -> See page 3	

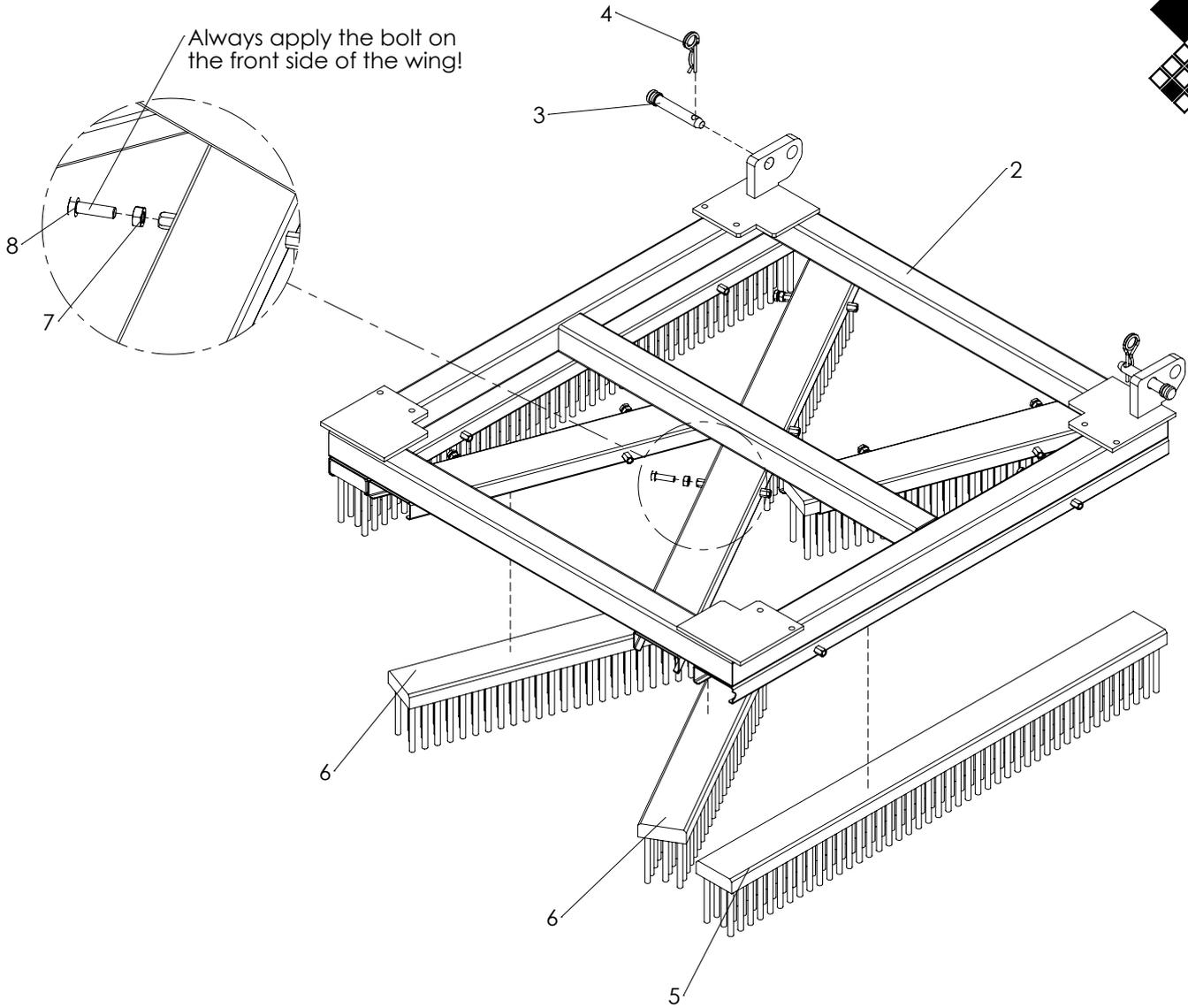

ITEM	PART NUMBER	DESCRIPTION	REMARKS	QUA
1		Sheet		-
2	494.102.110	Wing frame		1
3	521.191.120	Top Link Pin		2
4	523.051.000	R-clip Round 5, DIN 11024		2
5	486.909.110	Brush hair thickness 2.2mm (0.09") L=1100mm (43.3")	Color Yellow	2
	486.909.111	Brush hair thickness 1.5mm (0.06") L=1100mm (43.3")	Color Dark Blue	2
	486.909.112	Brush hair thickness 3mm (0.12") L=1100mm (43.3")	Color Light Blue	2
6	486.906.000	Brush hair thickness 2.2mm (0.09") L=600mm (23.6")	Color Yellow	4
	486.906.001	Brush hair thickness 1.5mm (0.06") L=600mm (23.6")	Color Dark Blue	4
	486.906.002	Brush hair thickness 3mm (0.12") L=600mm (23.6")	Color Light Blue	4
7	826.100.100	Nut M10 - DIN 934		12
8	804.100.350	Bolt M10 x 35 - ISO 4017		12
	246.400.014	Set of brushes hair thickness 2.2mm (0.09")	Color Yellow, set of brushes for 2 wings and the mid section.	
	246.400.012	Set of brushes hair thickness 1.5mm (0.06")	Color Light Blue, set of brushes for 2 wings and the mid section.	
	246.400.016	Set of brushes hair thickness 3mm (0.12")	Color Dark Blue, set of brushes for 2 wings and the mid section.	

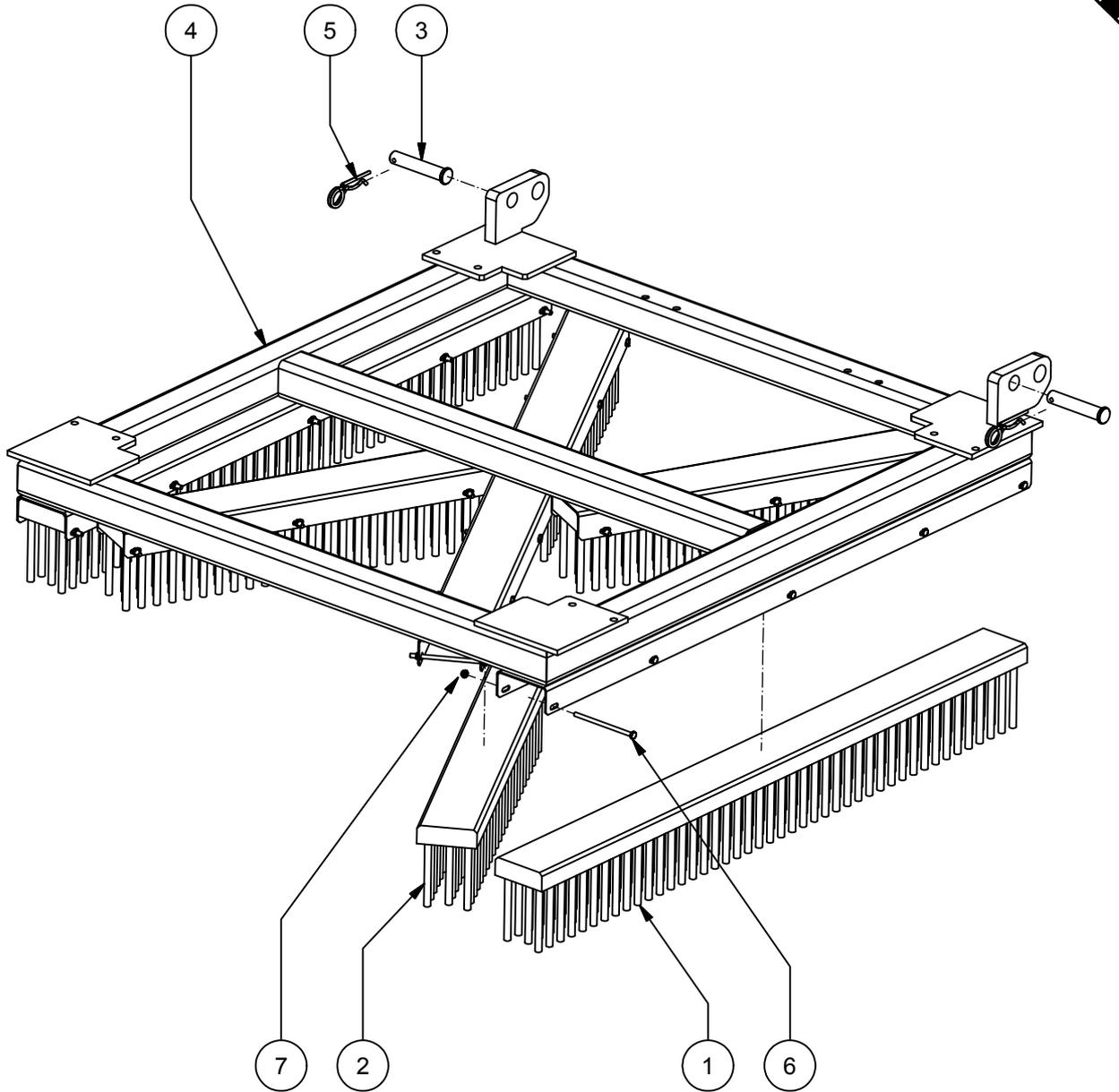

Redexim-Charterhouse Verti-Comb Pag 03 Code 1409

	PART #	DESCRIPTION	REMARKS	QUA
1	486.909.110	Brush Verti-Comb hair 2.2mm TL=1100	Color yellow	2
	486.909.111	Brush Verti-Comb hair 1.5mm TL=1100	Color dark blue	2
	486.909.112	Brush Verti-Comb hair 3mm TL=1100	Color light blue	2
2	486.906.000	Brush Verti-Comb hair 2.2mm TL=600	Color yellow	4
	486.906.001	Brush Verti-Comb hair 1.5mm TL=600	Color dark blue	4
	486.906.002	Brush Verti-Comb hair 3mm TL=600	Color light blue	4
3	2490825	Top Link Pin		2
4	494.102.110	Base frame 2		1
5	523.051.000	R-Pin 5 Din 11024		2
6	802.061.100	Bolt DIN 931-1 - M6 x 90		22
7	830.060.060	SL Nut DIN 985 - M6		22
	246.400.014	Set of brushes VC4000 2.2mm	Color yellow Set of brushes for the VC4000 includes brushes of 2 wings and mid section (VC1800) For the VC1800 brush set see page 2	
	246.400.012	Set of brushes VC4000 1.5mm	Color dark blue Set of brushes for the VC4000 includes brushes of 2 wings and mid section (VC1800) For the VC1800 brush set see page 2	
	246.400.016	Set of brushes VC4000 3mm	Color light blue Set of brushes for the VC4000 includes brushes of 2 wings and mid section (VC1800) For the VC1800 brush set see page 2	

Redexim-Charterhouse Verti-Comb Option: Bogy Kit Pag 04 Code 0935

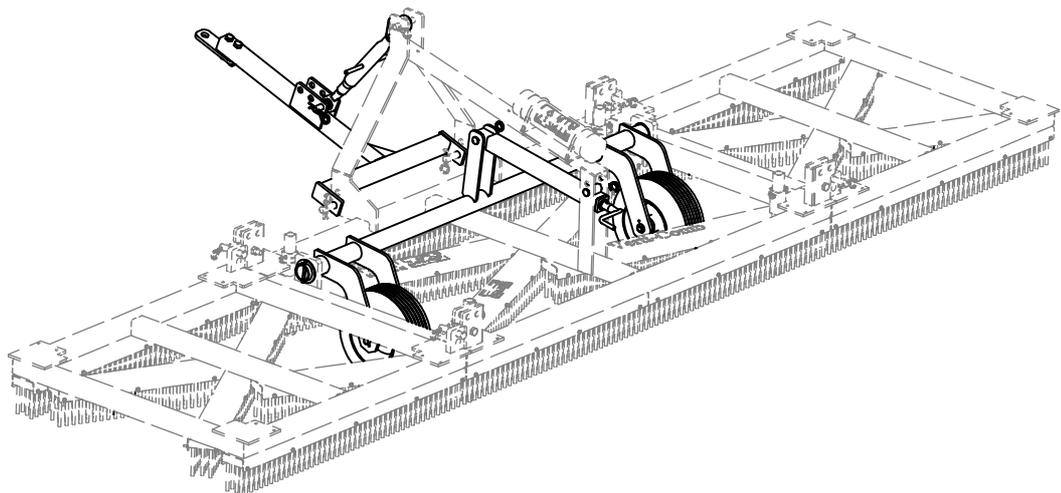
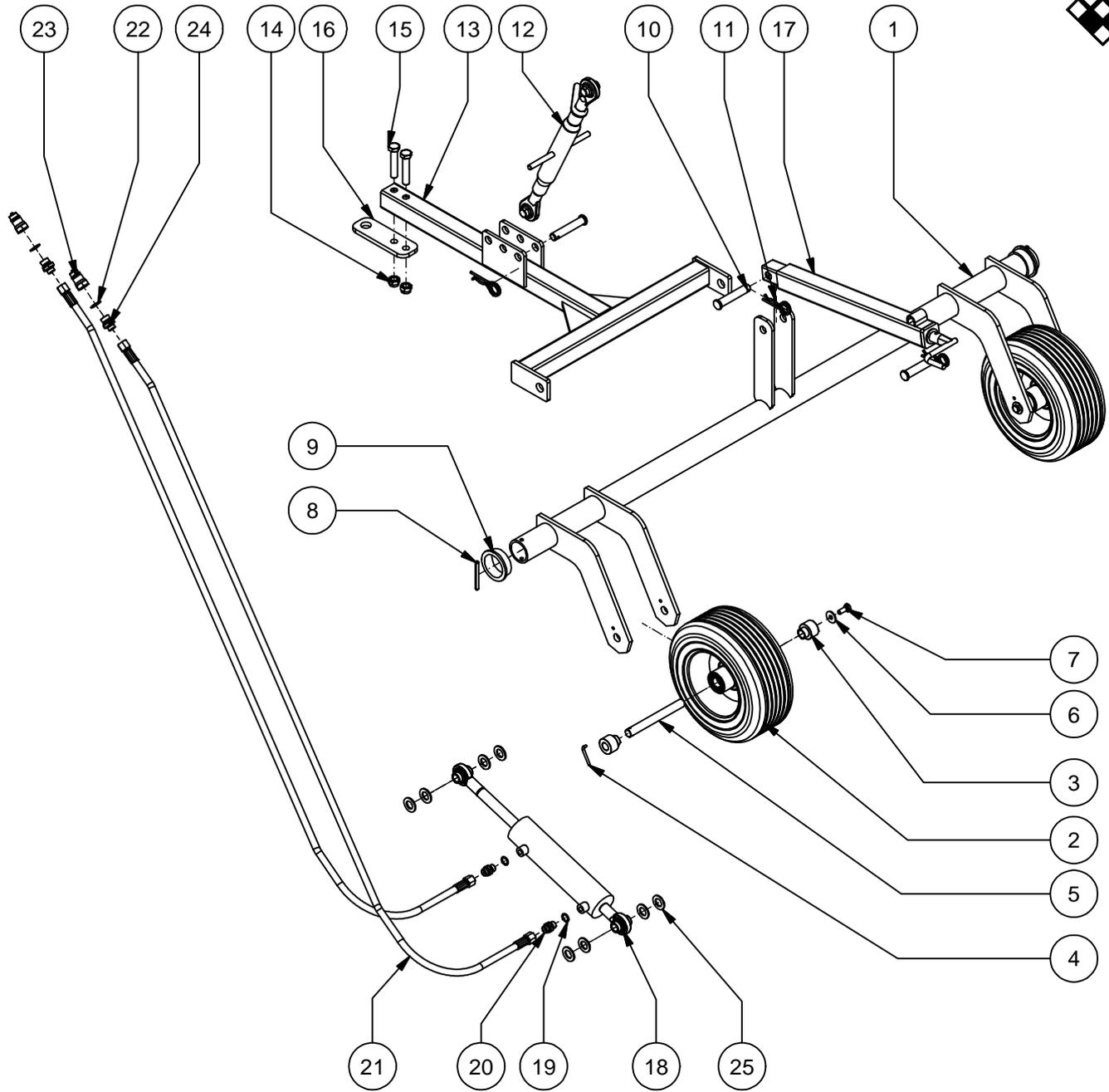

Redexim-Charterhouse Verti-Comb Option: Bogy Kit Pag 04 Code 0935

	PART #	DESCRIPTION	REMARKS	QUA
1	476.609.172	Wheel frame		1
2	511.325.135	Wheel 13x5.00-6 Hub L=100 Axle Dia=25		2
3	406.200.380	Distance bush		4
4	424.050.570	Wheel shaft pin		2
5	422.201.820	Wheel shaft		2
6	864.100.031	Large Washer DIN 9021 - 10,5		2
7	804.100.250	Bolt DIN 933 - M10 x 25		2
8	878.080.800	Roll Pin ISO 8752 - 8 x 80 .		2
9	442.600.800	Bush		2
10	2490825	Top Link Pin		4
11	523.051.000	R-Pin 5 Din 11024		4
12	522.194.450	Toplink		1
13	494.520.725	Draw Bar Bogy Verti-Clean		1
14	830.160.160	SL Nut DIN 985 - M16		2
15	802.160.800	Bolt DIN 931-1 - M16 x 80		2
16	464.101.800	Pull Eye Plate Bogy SS1600		1
17	460.050.633	Jack	Only in Bogy Kit Manual 246.400.004	1
18	534.301.750	Hydraulic cylinder 60x30, Stroke 175mm	Only in Bogy Kit Hydraulic 246.400.008	1
19	874.170.020	Copper washer 3/8"	Only in Bogy Kit Hydraulic 246.400.008	2
20	544.170.120	Straight Nipple 3/8" - Ø12mm	Only in Bogy Kit Hydraulic 246.400.008	2
21	541.132.002	Hose 2xM18 straight L=2000mm	Only in Bogy Kit Hydraulic 246.400.008	2
22	874.210.020	Copper washer 1/2"	Only in Bogy Kit Hydraulic 246.400.008	2
23	545.210.800	Quick Connector Male 1/2"	Only in Bogy Kit Hydraulic 246.400.008	2
24	544.130.402	Nipple 1/2" x 12mm	Only in Bogy Kit Hydraulic 246.400.008	2
25	864.200.030	Washer DIN 125 - M20	Only in Bogy Kit Hydraulic 246.400.008	8
	246.400.004	Bogy Kit Manual V-Comb 4000	Consists of parts 1-16 and 17	
	246.400.008	Bogy Kit Hydraulic V-Comb 4000	Consists of parts 1-16 and 18-25	

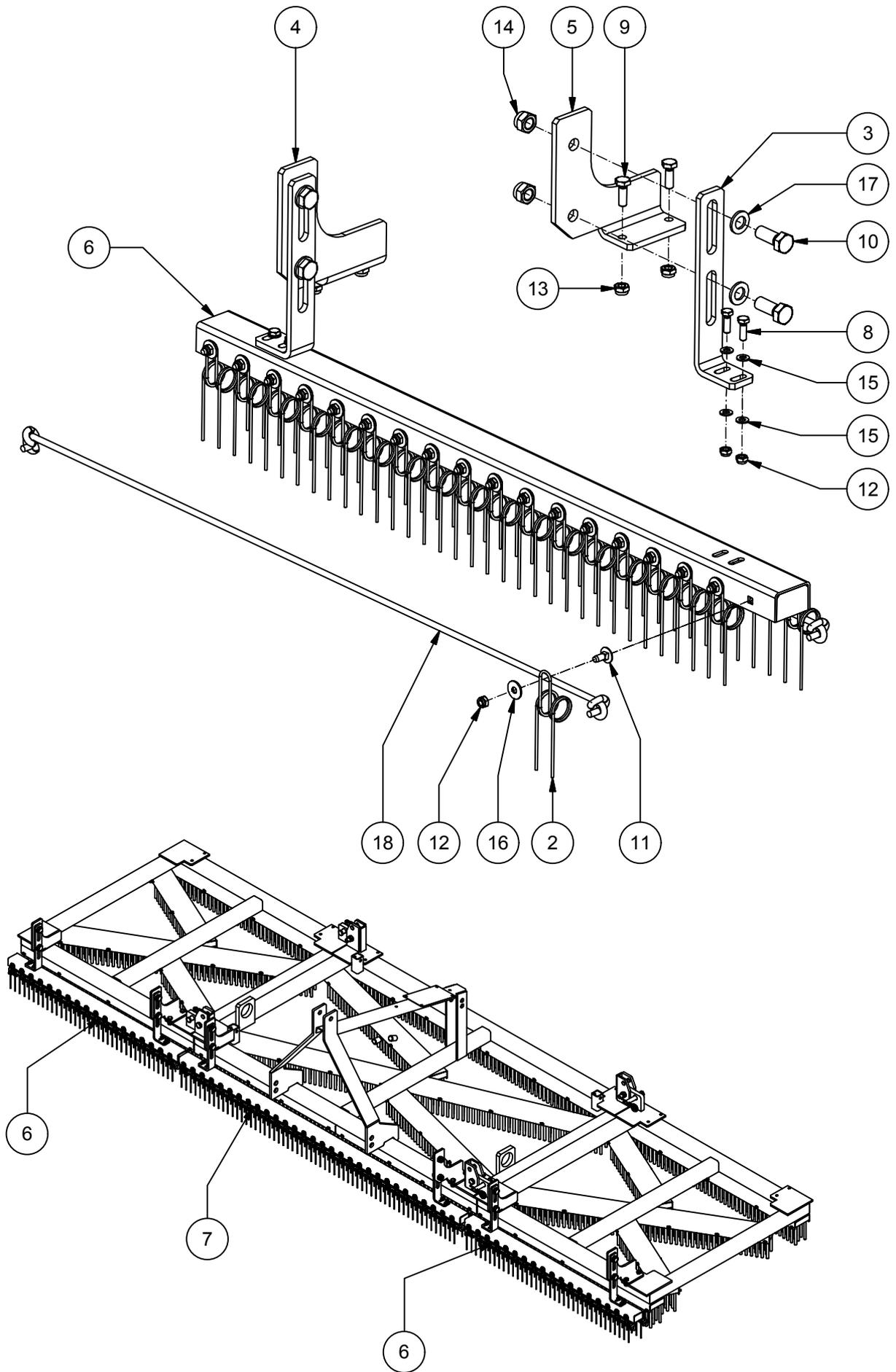

Redexim-Charterhouse Verti-Comb Option: Rake Kit Pag 05 Code 0935

	PART #	DESCRIPTION	REMARKS	QUA
1				
2	361.103.157	Tine For Rake VT		132
3	464.083.080	Mounting strip beam		6
4	468.082.460	Bracket for rake section Left		3
5	468.082.462	Bracket for rake section Right		3
6	470.609.109	Welding Assembly Beam L=1080		2
7	470.609.179	Welding Assembly Beam L=1790		1
8	804.080.250	Bolt DIN 933 - M8 x 25		12
9	804.100.300	Bolt DIN 933 - M10 x 30		12
10	804.160.400	Bolt DIN 933 - M16 x 40		12
11	820.080.200	MH Bolt DIN 603 - M8 x 20		132
12	830.080.080	SL Nut DIN 985 - M8		144
13	830.100.100	SL Nut DIN 985 - M10		12
14	830.160.160	SL Nut DIN 985 - M16		12
15	864.080.030	Washer DIN 125 - M8		24
16	864.080.031	Large Washer DIN 9021 - 8,4		132
17	864.160.030	Washer DIN 125 - M16		12
18	899.080.120	Rope For Spring Tines		6
	246.180.002	Rake section verti-comb 1800 complete		
	246.400.000	Rake section verti-comb 4000 complete		

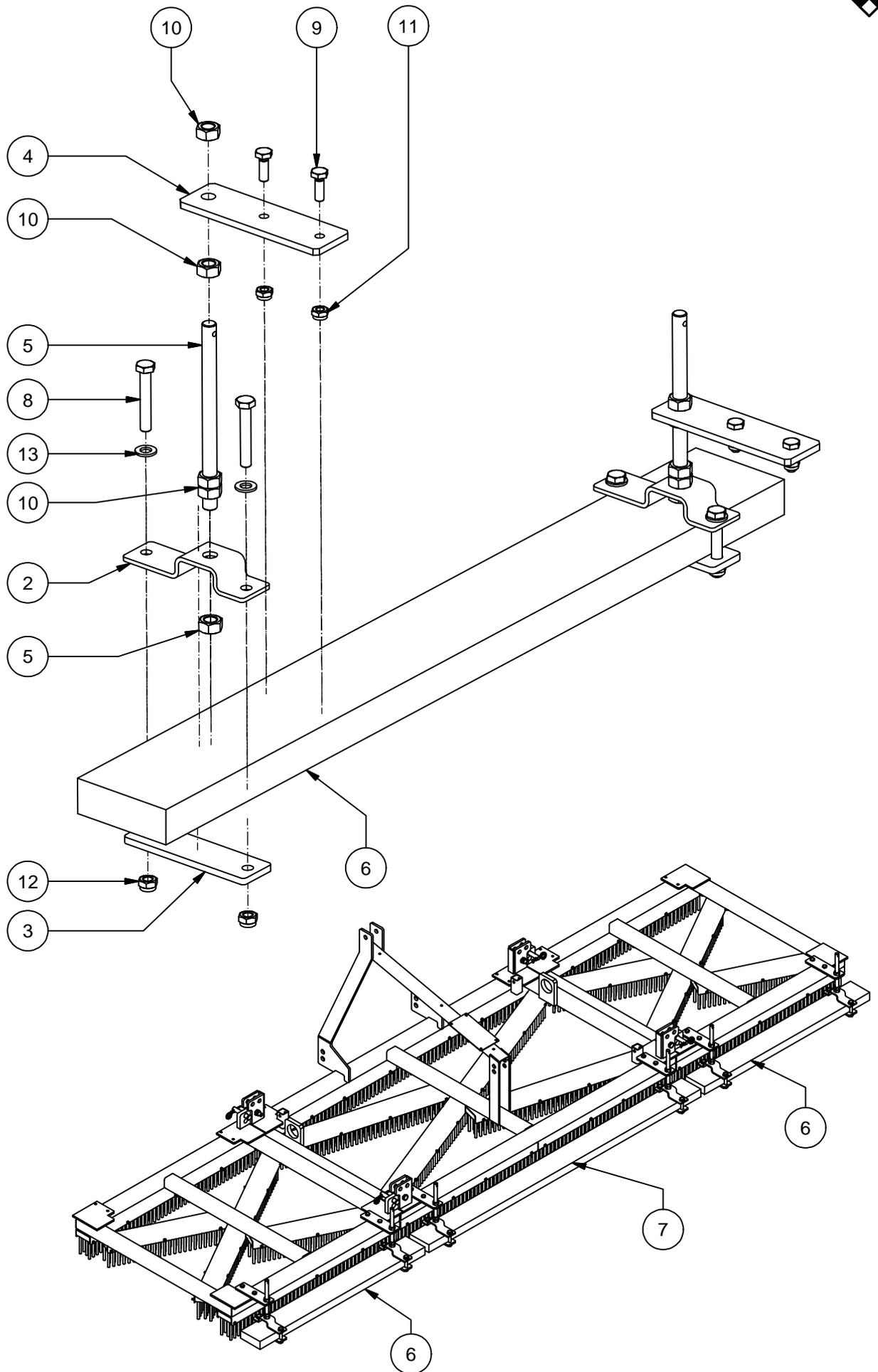

Redexim-Charterhouse Verti-Comb Option: Magnetic Bar Pag 06 Code 0935

	PART #	DESCRIPTION	REMARKS	QUA
1	246.400.002	Magnet kit complete		
2	464.051.740	Clamp Bracket		6
3	464.081.740	Clamp Strip		6
4	464.082.000	Mounting plate		6
5	490.162.320	Spindle		6
6	498.108.127	Magnetic Bar L=1080		2
7	498.178.127	Magnetic bar L=1780		1
8	802.120.750	Bolt DIN 931-1 - M12 x 75		12
9	804.100.300	Bolt DIN 933 - M10 x 30		12
10	826.160.160	Nut DIN 934 - M16		24
11	830.100.100	SL Nut DIN 985 - M10		12
12	830.120.120	SL Nut DIN 985 - M12		12
13	864.120.030	Washer DIN 125 - M12		12
	246.000.002	Magnet Kit Complete	Consists of parts 1-13	

Redexim-Charterhouse Verti-Comb Option: Hydraulic Kit Pag 07 Code 0941

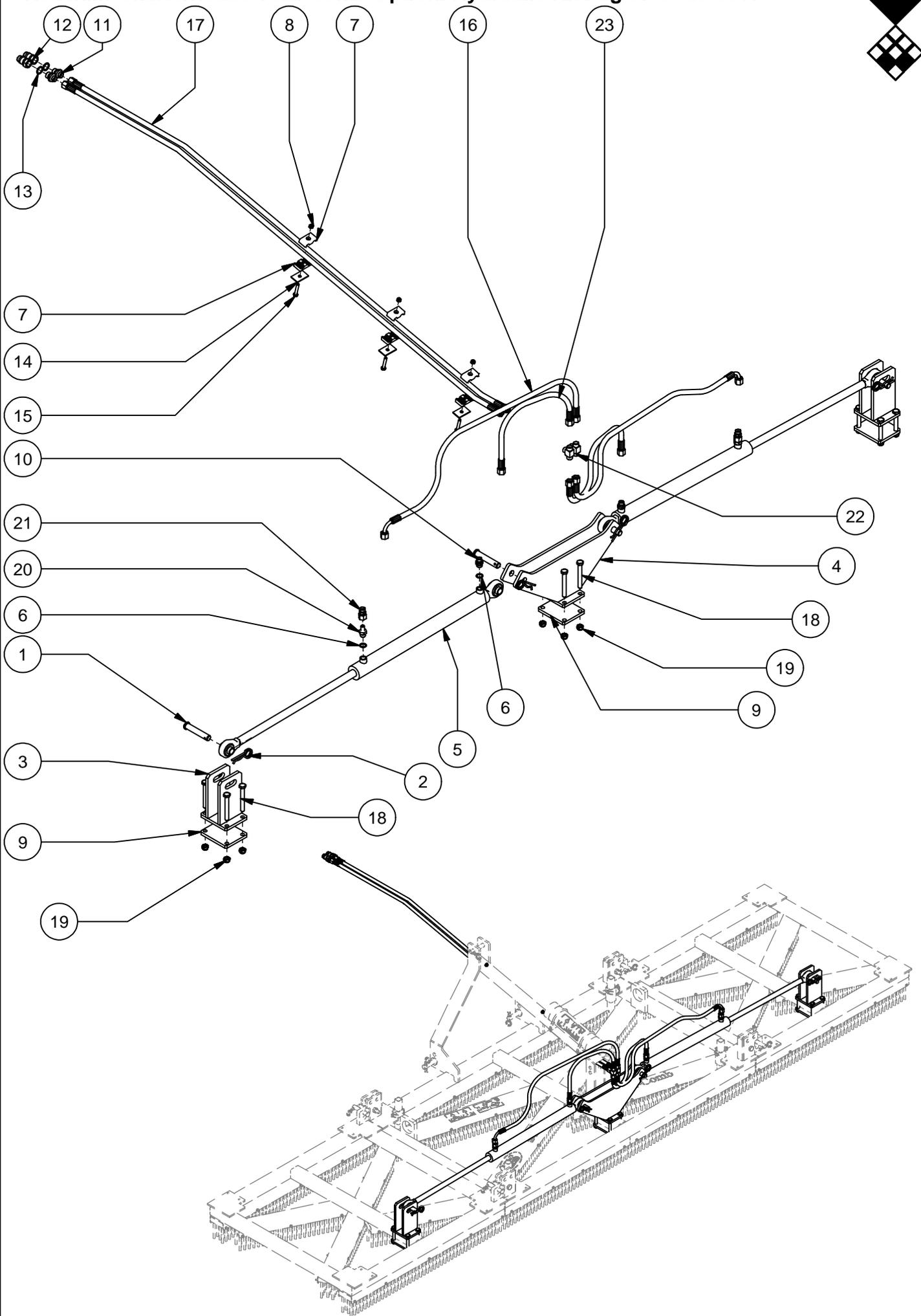

Redexim-Charterhouse Verti-Comb Option: Hydraulic Kit Pag 07 Code 0941

	PART #	DESCRIPTION	REMARKS	QUA
1	2490825	Top Link Pin		4
2	523.051.000	R-Pin 5 Din 11024		4
3	468.102.050	Bracket		2
4	468.102.960	Bracket		1
5	534.255.000	Hydraulic cylinder 40x25, Stroke 500mm		2
6	874.170.020	Copper washer 3/8"		4
7	547.150.150	Hose Clamp 2x Ø15		6
8	830.080.080	SL Nut DIN 985 - M8		3
9	468.101.200	Mounting plate		3
10	544.170.120	Straight Nipple 3/8" - Ø12mm		2
11	544.130.402	Nipple 1/2" x 12mm		2
12	545.210.800	Quick Connector Male 1/2"		2
13	874.210.020	Copper washer 1/2"		2
14	547.300.510	Deck Plate		3
15	802.080.450	Bolt DIN 931-1 - M8 x 45		3
16	541.130.852	Hose 2xM18 straight L=850mm		2
17	541.132.002	Hose 2xM18 straight L=2000mm		2
18	802.120.950	Bolt DIN 931-1 - M12 x 95		12
19	830.120.120	SL Nut DIN 985 - M12		12
20	543.170.410	Oil Flow Reducer WTS		2
21	544.121.120	Straight olive connector 12 mm		2
22	544.124.125	T-Connector		2
23	541.130.402	Hose 2xM18 straight L=400mm		2
	246.400.006	Hydraulic Kit for V-Comb 4000	Consists of parts 1-23	