

VERTI-DRAIN 7526



Version: 2434



Kwekerijweg 8 | 3709JA | Zeist | The Netherlands |
T: +31 (0)306 933 227
E: redexim@redexim.com
W: www.redexim.com

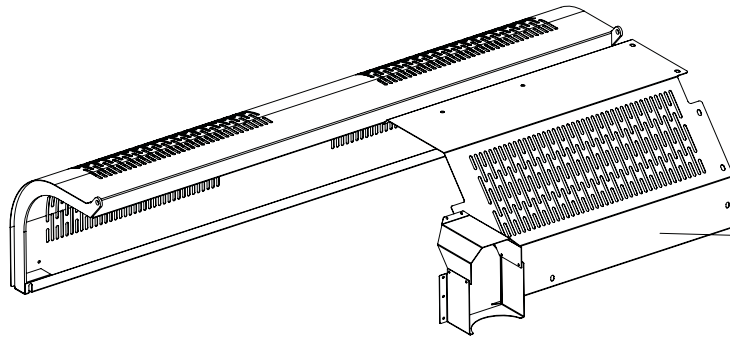

Page 3

Page 10-11

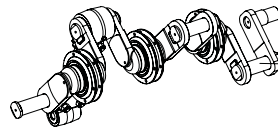
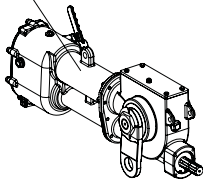

Page 5

Page 2

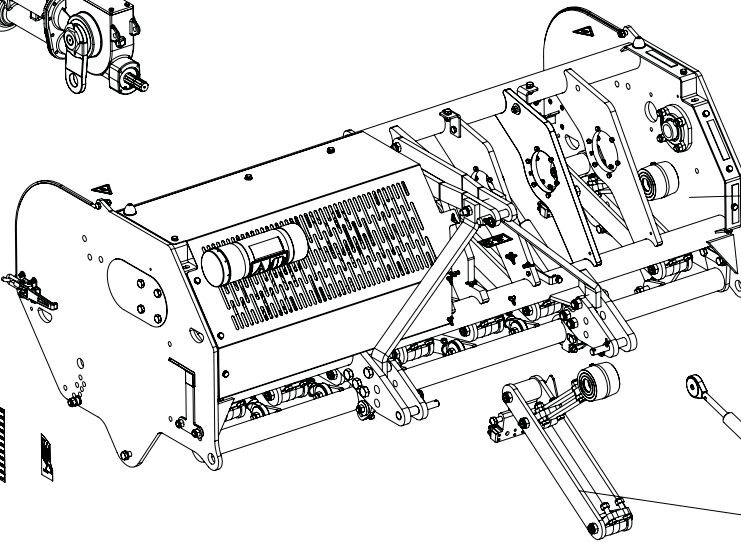

Page 6-7

Page 4

Page 9

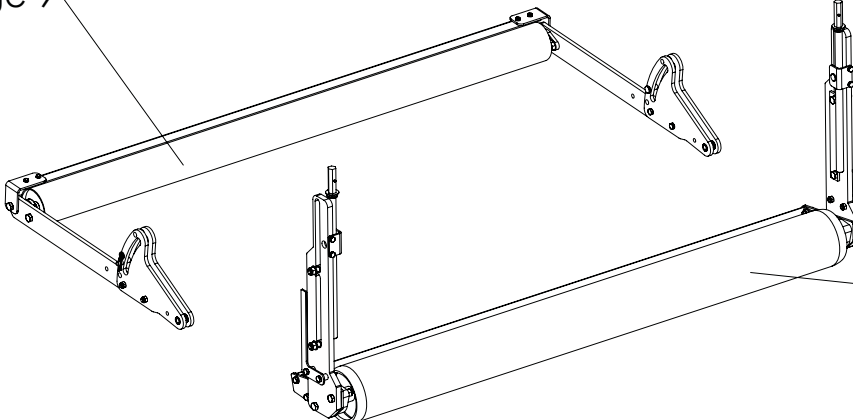

Page 8

Page 12: Tines
Page 13: Adapters and turf hold down kits
Page 14: PTO
Page 15-16: Optional wheel kit

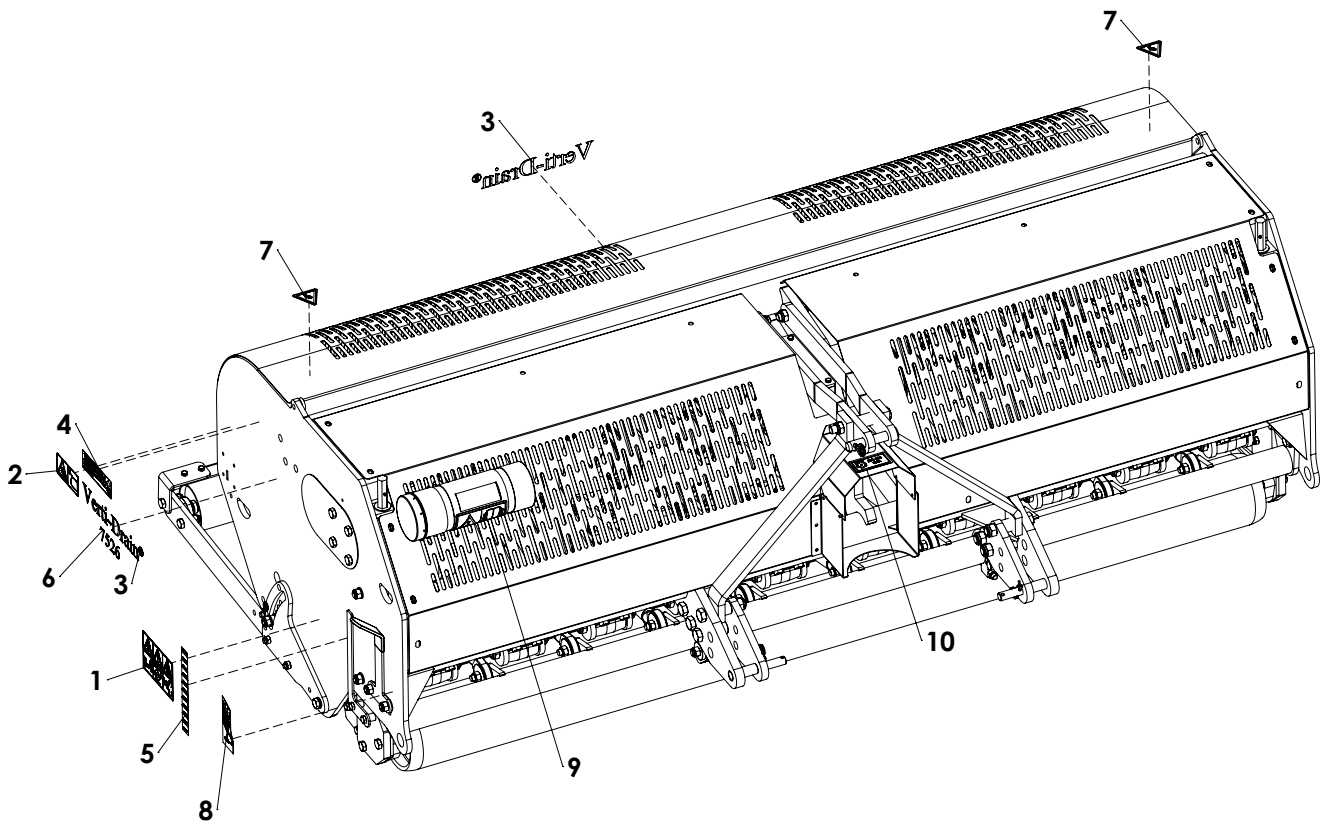

ITEM	PART NUMBER	DESCRIPTION	REMARKS	QUA
1	911.280.402	Safety Decall Verti-Drain		2
2	911.280.404	Decall close cover		2
3	911.260.402	Decall Verti-drain		3
4	900.260.403	Logo Label		2
5	900.260.412	Heigth label 150-400		2
6	911.260.420	Label 7526		2
7	900.280.404	Decall cut off fingers		2
8	911.260.404	Angle setting label VD		1
9	900.280.402	Safety decall manual		1
10	900.260.420	Decall PTO 300 500		1

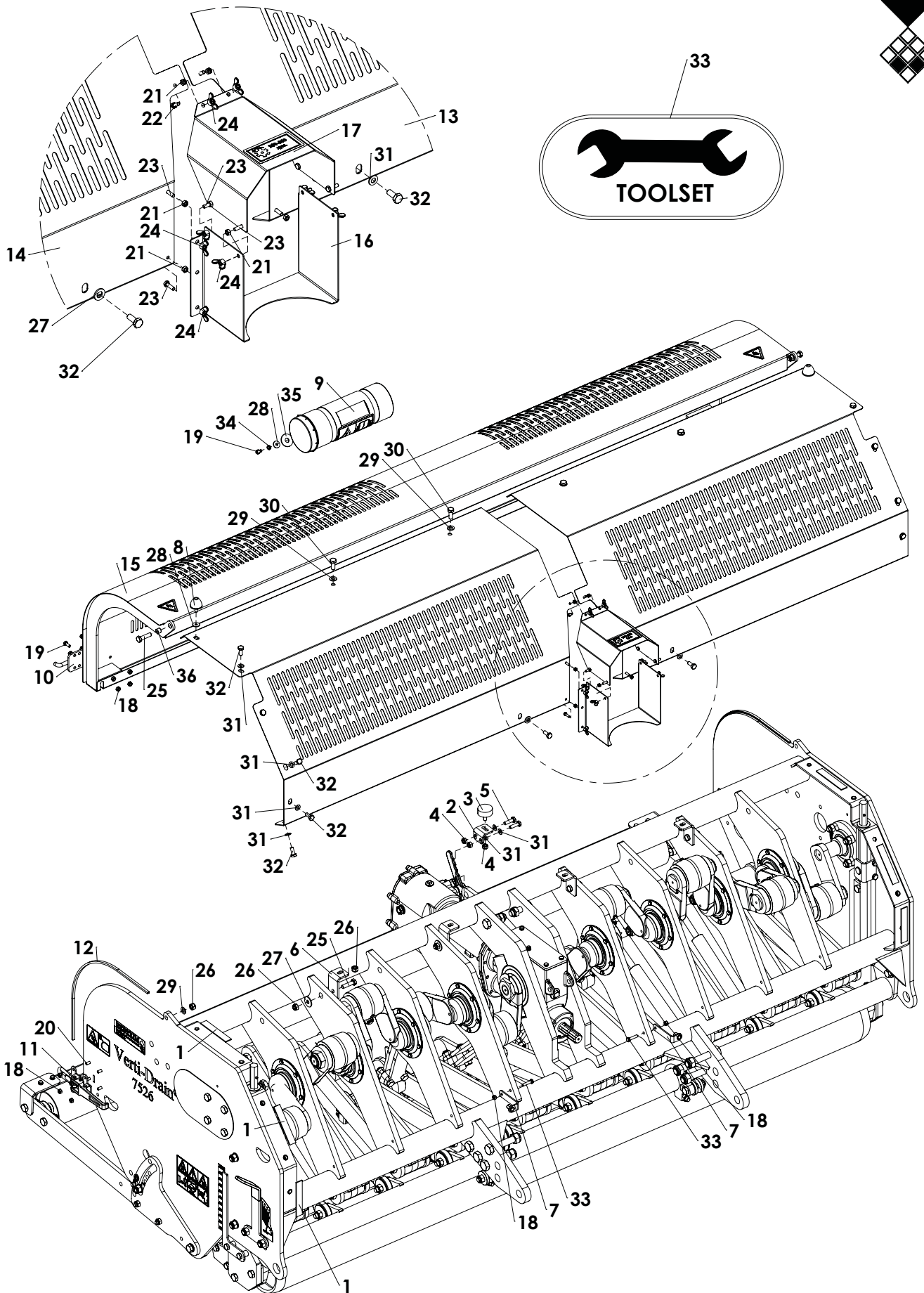

ITEM	PART NUMBER	DESCRIPTION	REMARKS	QUA
1	599.031.400	Foam rubber L=140		6
2	468.050.504	Cover bracket		1
3	D208112001	Rubber stop		1
4	830.100.100	Self Lock Nut M10 - ISO 10511		3
5	804.100.350	Bolt M10 x 35 - ISO 4017		2
6	2283201	Bracket		4
7	464.041.060	Bracket		2
8	446.080.550	Rubber stop		2
9	444.803.100	Toolbox Complete		1
10	470.061.710	Lock plate		2
11	590.342.700	Clamp		2
12	9500006	Rubber U-seal		2
13	456.132.700	Front cover left 7526		1
14	456.132.702	Front cover right 7526		1
15	456.269.048	Rear cover VD7526-7626		1
16	2282350	Bottom PTO Protection		1
17	2281782	TOP PTO protection cover		1
18	830.080.080	Self Lock Nut M8 - ISO 10511		18
19	804.080.200	Bolt M8 x 20 - ISO 4017		10
20	816.080.300	Bolt M8 x 30 - DIN 7991		8
21	826.060.060	Nut M6 - DIN 934		10
22	804.060.160	Bolt M6 x 16 - ISO 4017		2
23	804.060.200	Bolt M6 x 20 - ISO 4017		8
24	844.060.060	Winged nut		10
25	804.120.450	Bolt M12 x 45 - ISO 4017		6
26	830.120.120	Self Lock Nut M12 - ISO 10511		10
27	864.120.031	Large washer M12 - DIN 9021		4
28	864.080.024	Large washer M8 - DIN 9021		4
29	864.120.030	Washer M12 - ISO 7089		6
30	804.120.300	Bolt M12 x 30 - ISO 4017		4
31	864.100.030	Washer M10 - ISO 7089		12
32	804.100.250	Bolt M10 x 25 - ISO 4017		12
33	804.080.350	Bolt M8 x 35 - ISO 4017		2
34	866.080.020	Spring Washer M8 - DIN 127		2
35	864.140.031	Large washer M14 - DIN 9021		2
36	402.120.120	Distance bush		2
37	468.083.060	Set of tools		

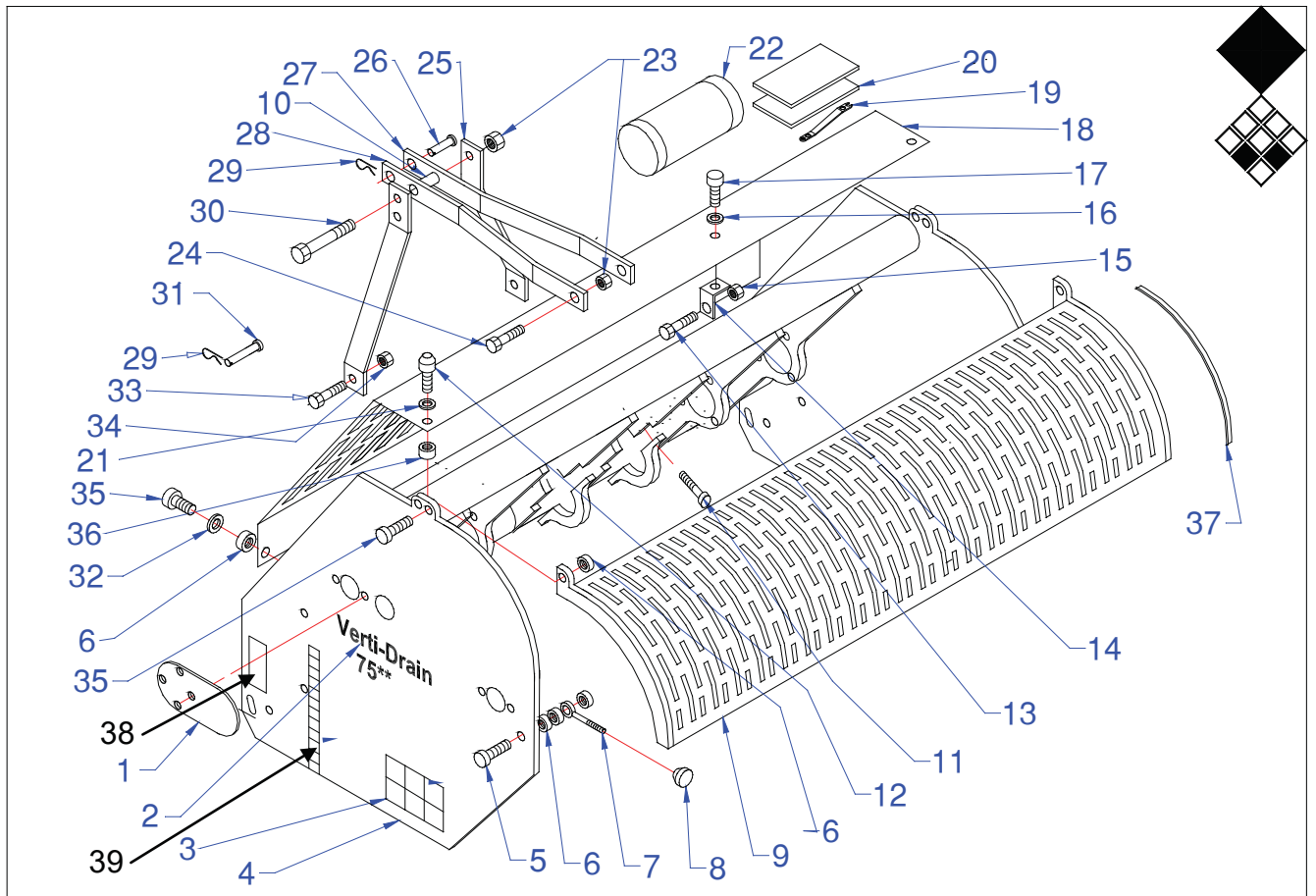

Redexim-Charterhouse Verti-Drain 7526 page 03 code 1225

	PART #	DESCRIPTION	REMARKS	QUA
1	2283224	Side cover plate 75 models		2
2	9700000	Verti-Drain 7526 decall set		1
3	9500002	Safety decall set 75 models		1
4	2306094	Main frame 7526		1
5	4001706	Bolt M10 x 60		2
6	4122000	Self lock nut M10		14
7	4091052	Eye bolt		2
8	2891200	Knurled nut		2
9	2283244	Rear cover 7526		1
10	2611930	Distance bush toplink 75		1
11	4012392	Gearbox support bolt		4
12	4972008	Rubber stop		2
13	4001858	Bolt M12 x 45		2
14	2283201	Front cover support		2
15	4122600	Self lock nut M12		4
16	4910120	Washer M12		4
17	4001842	Bolt M12 x 30		2
18	2212506	Front cover 7526		1
19	9100025	Combi-tool		1
20	9700004	User/ parts manual 7526		1
21	4910620	Washer		2
22	9100030	Manual/ tool box empty		1
23	4125000	Self lock nut M20		4
24	4002748	Bolt M20 x 70		2
25	2251858	Top link support strip		1
26	2490830	Top link pin CAT 2		1
27	2251852	Top link strip right		1
28	2251852	Top link strip left		1
29	4397008	Linch pin		3
30	4002828	Bolt M20 x 160		1
31	2490888	Bottom lift arm pin old	Complete with nut (old) for single plate	2
31	2490860	Pin	Use with dual plates	2
32	2910100	Washer M10		6
33	4002936	Bolt M22 x 120		6
34	4125850	Self lock nut M22		6
35	4001652	Bolt M10		6
36	4121400	Self lock nut M8		2
37	9500006	Rubber U seal		2
38	911.260.404	Angel setting label VD		1
39	900.260.409	Height label		2

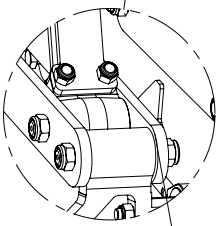
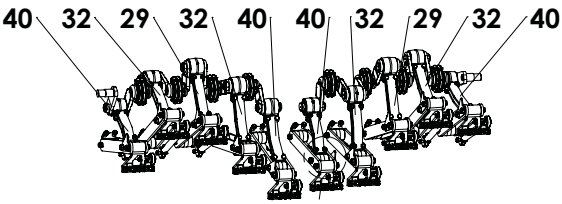
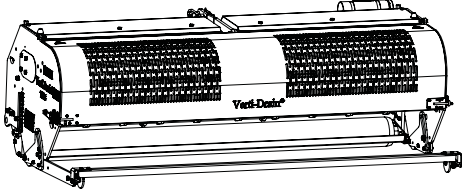
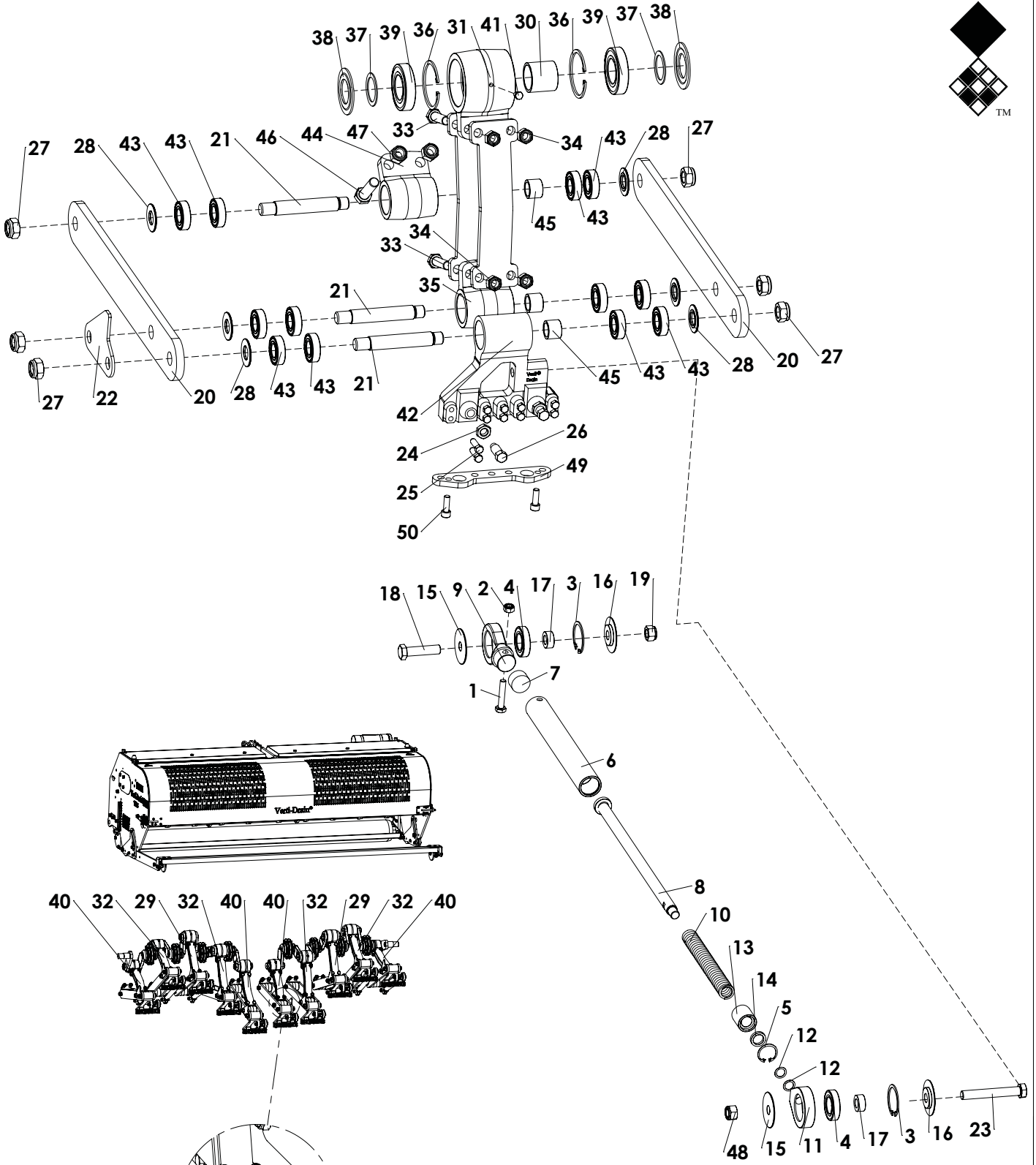

Only on this element mount the lock plate (2283256) on damper side to clear gearbox

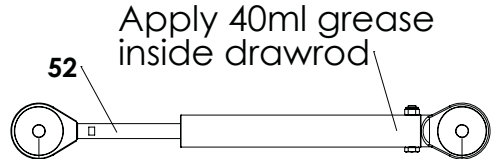

Apply 40ml grease inside drawrod

560 ⁺²mm (22.05"-22.12")

Use shim 4306000 to create correct length

ITEM	PART NUMBER	DESCRIPTION	REMARKS	QUA
1	802.100.550	Bolt M10 x 55 - ISO 4014		1
2	830.100.100	Self Lock Nut M10 - ISO 10511		1
3	872.055.200	Circlip D=55 - DIN 472		2
4	713.300.130	Bearing 6006 LLU		2
5	872.035.150	Circlip D=35 - DIN 472		1
6	476.423.180	Tube for drawrod 75		1
7	2891110	Rubber stop		1
8	2283220	Draw rod 75		1
9	448.421.150	Draw rod head with stud		1
10	4781802	Compression spring		1
11	2991102	Draw rod head		1
12	4306000	Shim	Use as many to calibrate	2
13	2602454	Bush		1
14	4480015	Seal		1
15	404.160.050	Dust washer Ø65/Ø38/Ø16 L=5.25		2
16	404.160.070	Dust washer Ø65/Ø38/Ø16 L=7.25		2
17	406.160.130	Distance bush		2
18	416.160.700	Special bolt M16		1
19	831.160.160	Self Lock Nut M16x1.5 - ISO 10511		1
20	2941800	Arm strip 75		2
21	2490452	Support axis 75		3
22	2283256	Lock plate for tine holder		1
23	802.161.100	Bolt M16 x 110 - ISO 4014		1
24	826.160.080	Low Nut M16 - DIN 439		2
25	4001675	Tine holder bolt M10x35		10
26	4002315	Tine holder Bolt M16 x 40		2
27	4125800	Self Lock Nut M22 - ISO 10511		6
28	2661700	Distance washer		6
29	2382694	Connecting rod outer 75		4
30	2604522	Inner bush		1
31	492.951.610	Big end empty 75		1
32	2382690	Connecting rod middle 75		2
33	802.160.650	Bolt M16 x 65 - ISO 4014 - 10.9		4
34	830.160.160	Self Lock Nut M16-ISO 10511 Class 10		4
35	2432102	Bearing support house empty 75	Replaces version with 2x circlip 872.035.150	1
36	872.085.300	Circlip D=85 - DIN 472		2
37	2604520	Distance washer big end		2
38	2661621	Dust cover big end		2
39	713.450.190	Bearing 6209-LLU		2
40	2382692	Connecting rod center 75		8
41	804.080.160	Bolt M8 x 16 - ISO 4017		1
42	492.742.180	Tine holder empty 75		4
43	713.250.150	Bearing 6205-LLU		12
44	448.088.122	Bearing support house empty 75	Check mounting holes Ø18.2mm (0.72")	1
	2432102	Bearing support house empty 75	Check mounting holes Ø16.2mm (0.64")	1
45	2602452	Inner bush		3
46	802.180.700	Bolt M18 x 70 - ISO 4014 Class 10.9	Check diameter 18mm (0.71")	2
	802.160.650	Bolt M16 x 65 - ISO 4014 Class 10.9	Check diameter 16mm (0.63")	2
47	830.180.180	Self Lock Nut M18 - ISO 10511 - 10.9	Check diameter 18mm (0.71")	2
	830.160.160	Self Lock Nut M16 - ISO 10511 - 10.9	Check diameter 16mm (0.63")	2
48	830.160.160	Self Lock Nut M16-ISO 10511 Class 10		1
49	468.102.230	Additional tine plate holder		1
50	814.100.300	Bolt M10 x 30 - DIN 912		2
51	490.345.600	Drawrod complete	Total needed	10

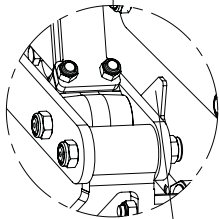
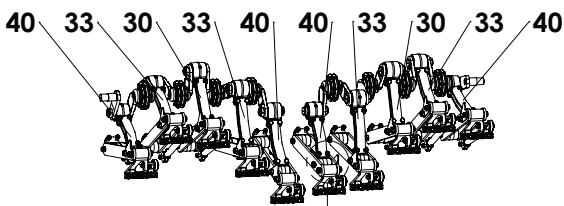
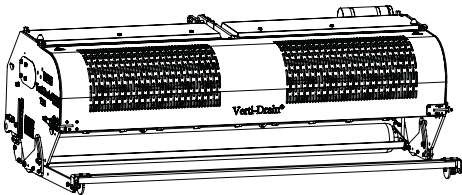
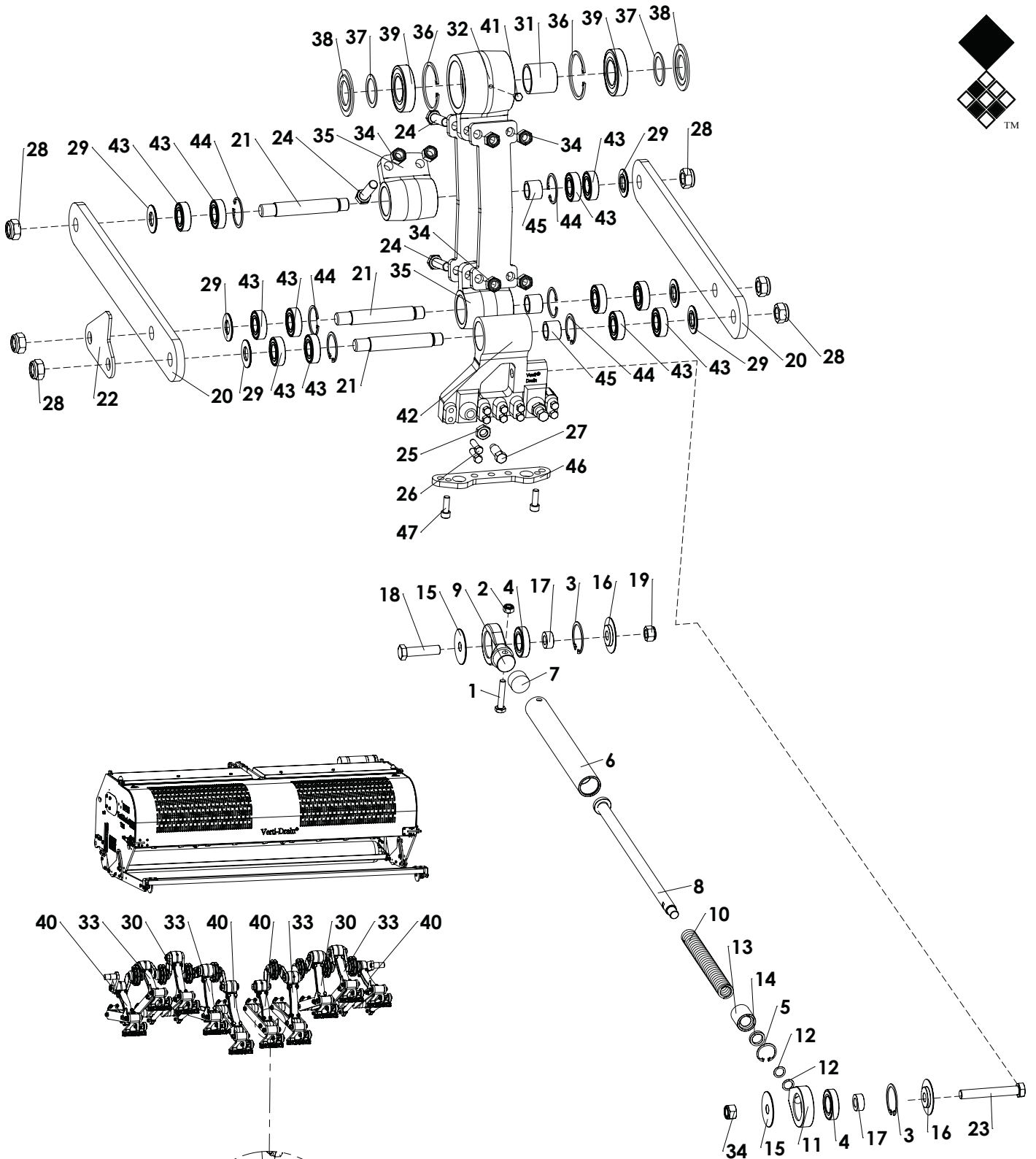

Only on this element mount the lock plate (2283256) on damper side to clear gearbox

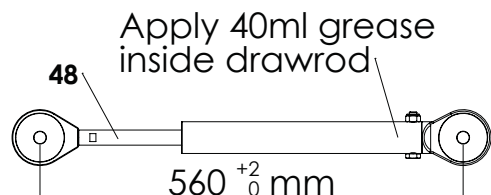

Use shim 4306000 to create correct length

ITEM	PART NUMBER	DESCRIPTION	REMARKS	QUA
1	802.100.550	Bolt M10 x 55 - ISO 4014	Quantity for 1 element	1
2	830.100.100	Self Lock Nut M10 - ISO 10511	Quantity for 1 element	1
3	872.055.200	Circlip D=55 - DIN 472	Quantity for 1 element	2
4	713.300.130	Bearing 6006 LLU	Quantity for 1 element	2
5	872.035.150	Circlip D=35 - DIN 472	Quantity for 1 element	1
6	476.423.180	Tube for drawrod 75	Quantity for 1 element	1
7	2891110	Rubber stop	Quantity for 1 element	1
8	2283220	Draw rod 75	Quantity for 1 element	1
9	448.421.150	Draw rod head with stud	Quantity for 1 element	1
10	4781802	Compression spring	Quantity for 1 element	1
11	2991102	Draw rod head	Quantity for 1 element	1
12	4306000	Shim	Quantity for 1 element	2
13	2602454	Bush	Quantity for 1 element	1
14	4480015	Seal	Quantity for 1 element	1
15	404.160.050	Dust washer Ø65/Ø38/Ø16 L=5.25	Quantity for 1 element	2
16	404.160.070	Dust washer Ø65/Ø38/Ø16 L=7.25	Quantity for 1 element	2
17	406.160.130	Distance bush	Quantity for 1 element	2
18	416.160.700	Special bolt M16	Quantity for 1 element	1
19	831.160.160	Self Lock Nut M16x1.5 - ISO 10511	Quantity for 1 element	1
20	2941800	Arm strip 75	Quantity for 1 element	2
21	2490452	Support axis 75	Quantity for 1 element	3
22	2283256	Lock plate for tine holder	Quantity for 1 element	1
23	802.161.100	Bolt M16 x 110 - ISO 4014	Quantity for 1 element	1
24	802.160.650	Bolt M16 x 65 - ISO 4014	Quantity for 1 element	6
25	826.160.080	Low Nut M16 - DIN 439	Quantity for 1 element	2
26	4001675	Tine holder bolt M10x35	Quantity for 1 element	10
27	4002315	Tine holder Bolt M16 x 40	Quantity for 1 element	2
28	4125800	Self Lock Nut M22 - ISO 10511	Quantity for 1 element	6
29	2661700	Distance washer	Quantity for 1 element	6
30	2382694	Connecting rod outer 75	Quantity for 1 element	2
31	2604522	Inner bush	Quantity for 1 element	1
32	492.951.610	Big end empty 75	Quantity for 1 element	1
33	2382690	Connecting rod middle 75	Quantity for 1 element	2
34	830.160.160	Self Lock Nut M16 - ISO 10511	Quantity for 1 element	7
35	2432102	Bearing support house empty 75	Quantity for 1 element	2
36	872.085.300	Circlip D=85 - DIN 472	Quantity for 1 element	2
37	2604520	Distance washer big end	Quantity for 1 element	2
38	2661621	Dust cover big end	Quantity for 1 element	2
39	713.450.160	Bearing 6209-LLU	Quantity for 1 element	2
40	2382692	Connecting rod center 75	Quantity for 1 element	2
41	804.080.160	Bolt M8 x 16 - ISO 4017	Quantity for 1 element	1
42	492.742.180	Tine holder empty 75	Quantity for 1 element	1
43	713.250.150	Bearing 6205-LLU	Quantity for 1 element	12
44	872.052.200	Circlip D=52 - DIN 472	Quantity for 1 element	6
45	2602452	Inner bush	Quantity for 1 element	3
46	468.102.230	Additional tine plate holder	Quantity for 1 element	1
47	814.100.300	Bolt M10 x 30 - DIN 912	Quantity for 1 element	2
48	490.345.600	Drawrod complete		10

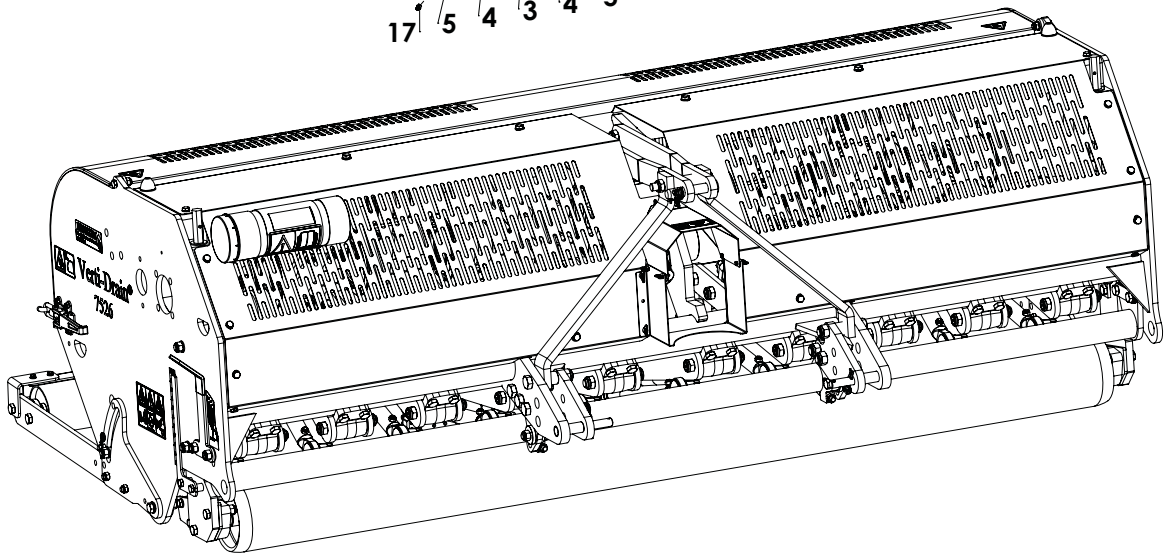
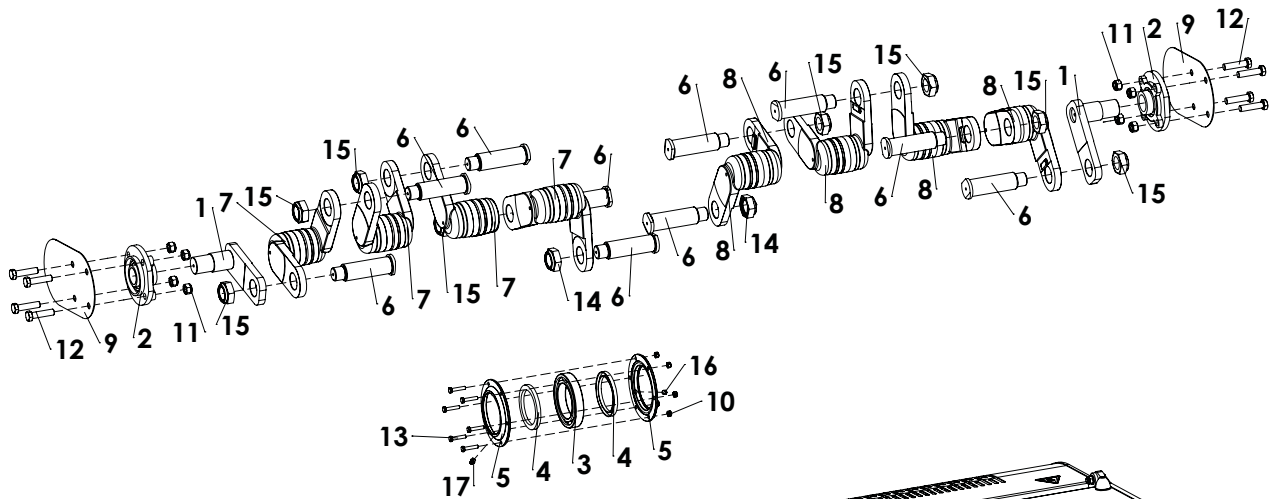

ITEM	PART NUMBER	DESCRIPTION	REMARKS	QUA
1	470.200.804	End crank 7526		2
2	741.450.590	Bearing UELFC 209		2
3	711.950.240	Bearing 6019		8
4	4410310	Oil Seal 95x120x10 RP		16
5	468.151.804	Crank cover empty		16
6	2490182	Big end pin		10
7	2441720	7526 Left crank		4
8	2441716	7526 Right crank		4
9	468.023.310	Side cover plate		2
10	830.080.080	Self Lock Nut M8 - ISO 10511		48
11	830.160.160	Self Lock Nut M16 - ISO 10511		8
12	802.160.650	Bolt M16 x 65 - ISO 4014		8
13	802.080.400	Bolt M8 x 40 - ISO 4014		48
14	4129200	Nut M35x1.5		2
15	4129210	Nut M35x1.5		8
16	4067000	Breather M10x1		8
17	4061150	Grease nipple M10x1		8

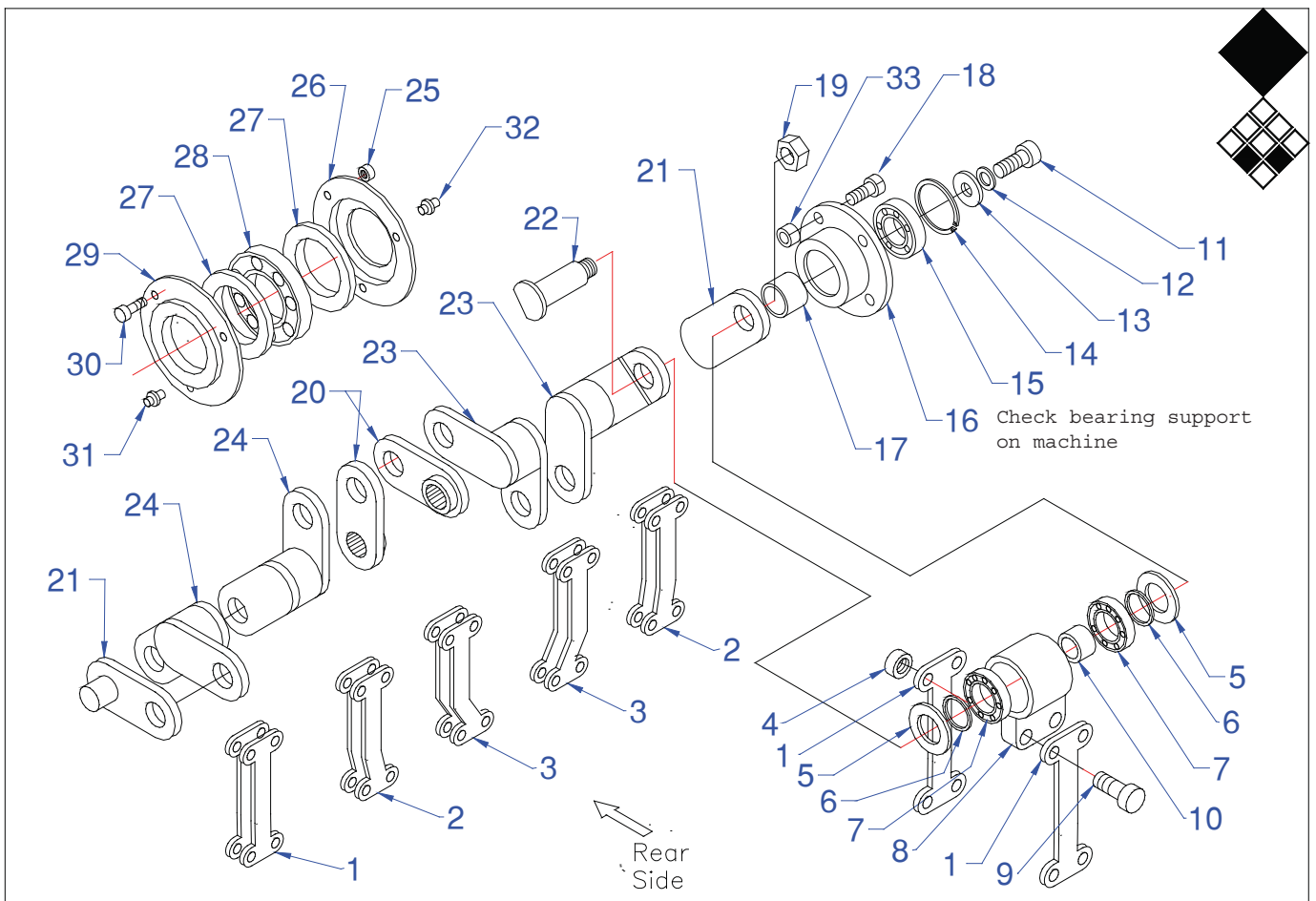

Redexim-Charterhouse Verti-Drain 7526 page 05 code 0104

	PART #	DESCRIPTION	REMARKS	QUA
1	2382694	Connecting rod straight 75		4
2	2382690	Connecting rod little bent 75		8
3	2382692	Connecting rod bent 75		8
4	4123800	Self lock nut M16		20
5	2661621	Dust cover big end		20
6	2604520	Distance washer big end		20
7	4815880	Sealed bearing 6209 2RS		20
8	2437640	Big end empty 75		10
9	4002352	Bolt M16 x 65		20
10	2604522	Inner bush		10
11	4002028	Bolt M14 x 35 x 1.5		2
12	4211100	Spring washer		2
13	2611928	Washer		2
14	4720085	Cir clip D 85		2
15	4815880	Sealed bearing 6209 2RS		2
16	2471870	Bearing support house crankshaft 75		2
17	2691932	Distance bush crank handle		2
18	4001874	Bolt M12 x 55		8
19	4129210	Big end pin nut	Use loctite	8
20		Splined arm	See page 11 for more information	
21	2444812	Crank handle		2
22	2490182	Big end pin		10
23	2441720	Left hand crank 7526	Note: assembled at right side of machine	4
24	2441716	Right hand crank 7526	Note: assembled at left side of machine	4
25	4121400	Self lock nut M8		48
26	2661658	Crank cover empty with breather	Use liquid paste for sealing to main frame	8
27	4410310	Oil seal 95x120x10 RP		16
28	4814200	Bearing 6019		8
29	2661658	Crank cover with grease nipple	Use liquid paste for sealing to main frame	8
30	4001470	Bolt M8 x 45		48
31	4061150	Grease nipple		4
32	4067000	Breather		4
33	4122600	Self lock nut M12		4
	1992730	pos 26-27-32		
	1992732	pos 27-29-31		

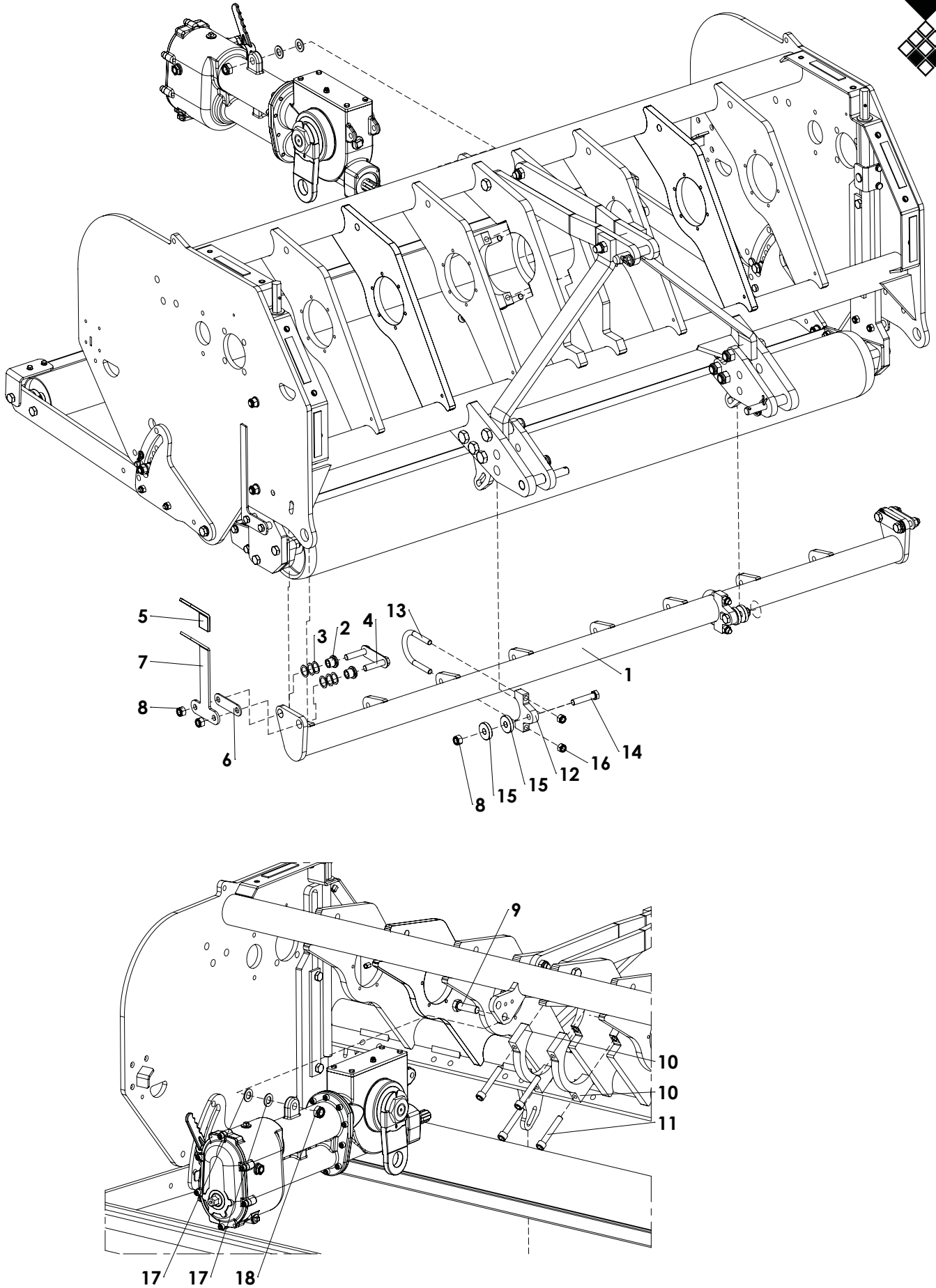

ITEM	PART NUMBER	DESCRIPTION	REMARKS	QUA
1	2382684	Central bar 7526		1
2	2611922	Bush for central bar		4
3	4306050	Shim		12
4	2283222	Bolt assembly central bar		2
5	446.401.250	Cover for lever 75 serie		1
6	2611924	Distance plate		2
7	2283230	Handle for adjusting angle 75		1
8	830.160.160	Self Lock Nut M16 - ISO 10511		6
9	802.200.650	Bolt M20 x 65 - ISO 4014		1
10	2479520	Bracket		2
11	814.161.000	DIN 912 - M16x100		4
12	466.279.000	Support bolt assy central bar		2
13	848.791.360	U-Bolt M14		2
14	802.160.750	Bolt M16 x 75 - ISO 4014		2
15	402.160.100	Distance washer Ø16.5/Ø50 L=10		4
16	830.140.140	Self Lock Nut M14 - ISO 10511		4
17	864.200.030	Washer M20 - ISO 7089		2
18	830.200.200	Self Lock Nut M20 Din 985 h=17		1

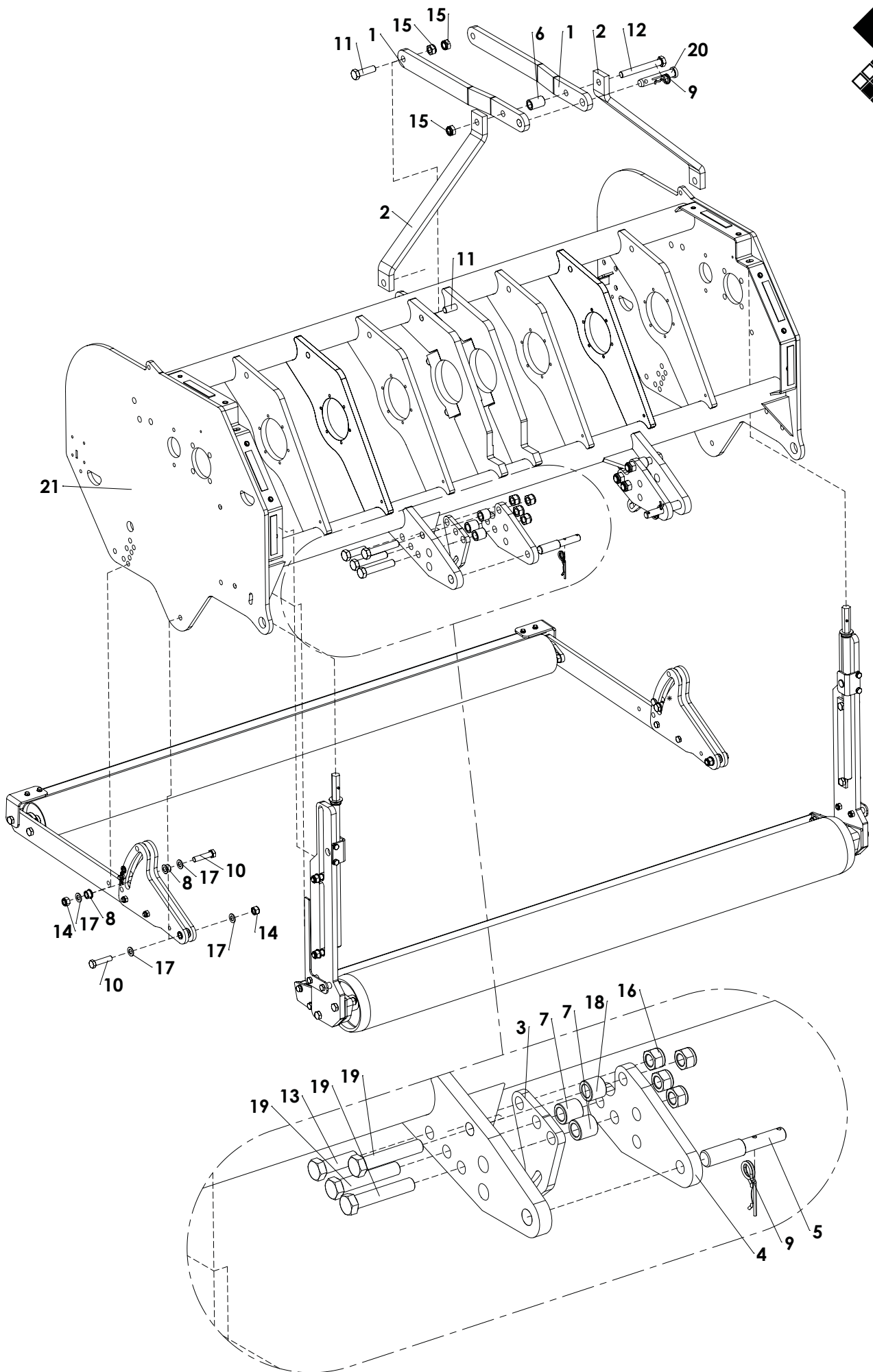

ITEM	PART NUMBER	DESCRIPTION	REMARKS	QUA
1	2251852	3-point arm 20mm		2
2	2251858	3-point strip		2
3	2283207	Central bar support		2
4	2283260	3-point plate		2
5	2490860	3-Point pin Ø28/Ø22 L=160		2
6	2611930	Distance bush toplink		1
7	2611942	Distance bush		4
8	404.160.160	Pivot bush		4
9	523.051.000	R-clip Round 5, DIN 11024		3
10	802.160.700	Bolt M16 x 70 - ISO 4014		4
11	802.200.700	Bolt M20 x 70 - ISO 4014		3
12	802.201.600	Bolt M20 x 160 - ISO 4014		1
13	802.220.700	Bolt M22 x 70 - ISO 4014		2
14	830.160.160	Self Lock Nut M16 - ISO 10511		4
15	830.200.200	Self Lock Nut M20 Din 985 h=17		3
16	830.220.220	Self Lock Nut M22 - ISO 10511		8
17	864.160.030	Washer M16 - ISO 7089		8
18	406.220.300	Distance bush Ø35/Ø22 L=30		2
19	802.221.200	Bolt M22 x 120 - ISO 4014		6
20	521.251.380	Top link pin		1
21	2306094	Frame 7526		1

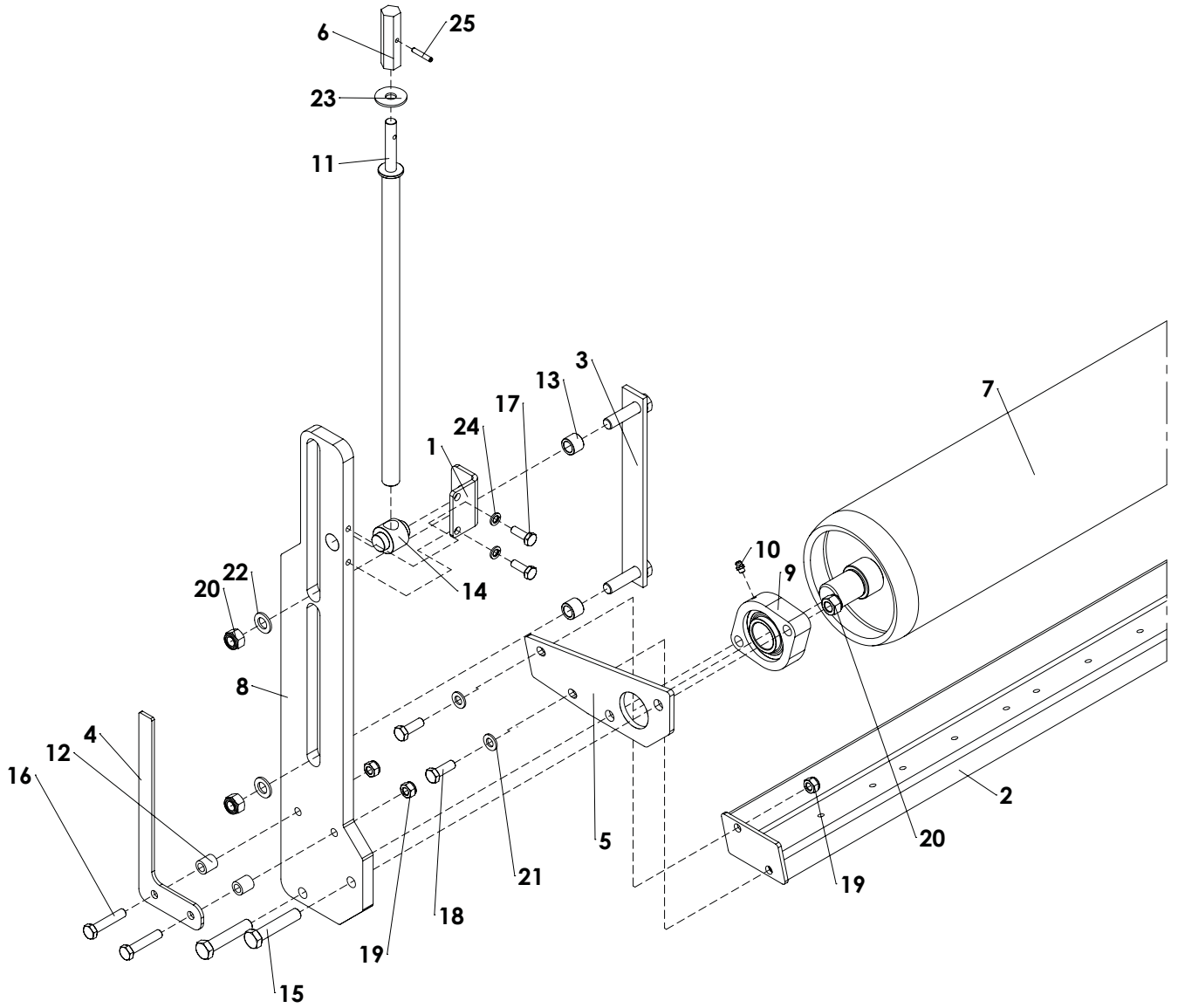

ITEM	PART NUMBER	DESCRIPTION	REMARKS	QUA
1	2283200	Spindle nut support 75		2
2	2283214	Scraper 7526		1
3	2283226	Front roller support bolt assy		2
4	2283228	Height indicator 75		2
5	2283232	Front roller scraper support 75		2
6	2283234	Spindle head 75		2
7	2344434A	Front roller VD7526		1
8	2382606	Front roller support 75		2
9	2471872	Front roller bearing		2
10	880.080.100	Grease nipple M8 DIN 71412A		2
11	2692108	Front roller spindle 75		2
12	402.130.220	Bush Ø20 L=22		4
13	402.160.190	Distance bush		4
14	4972870	Front roller spindle nut		2
15	802.160.800	Bolt M16 x 80 - ISO 4014		4
16	802.120.600	Bolt M12 x 60 - ISO 4014		4
17	804.100.300	Bolt M10 x 30 - ISO 4017		4
18	804.120.350	Bolt M12 x 35 - ISO 4017		4
19	830.120.120	Self Lock Nut M12 - ISO 10511		8
20	830.160.160	Self Lock Nut M16 - ISO 10511		8
21	864.120.030	Washer M12 - ISO 7089		4
22	864.160.030	Washer M16 - ISO 7089		4
23	864.140.031	Large washer M14 - DIN 9021		2
24	866.100.020	Spring Washer M10 - DIN 127		4
25	878.060.350	Roll Pin 6 x 35 - ISO 8752		2

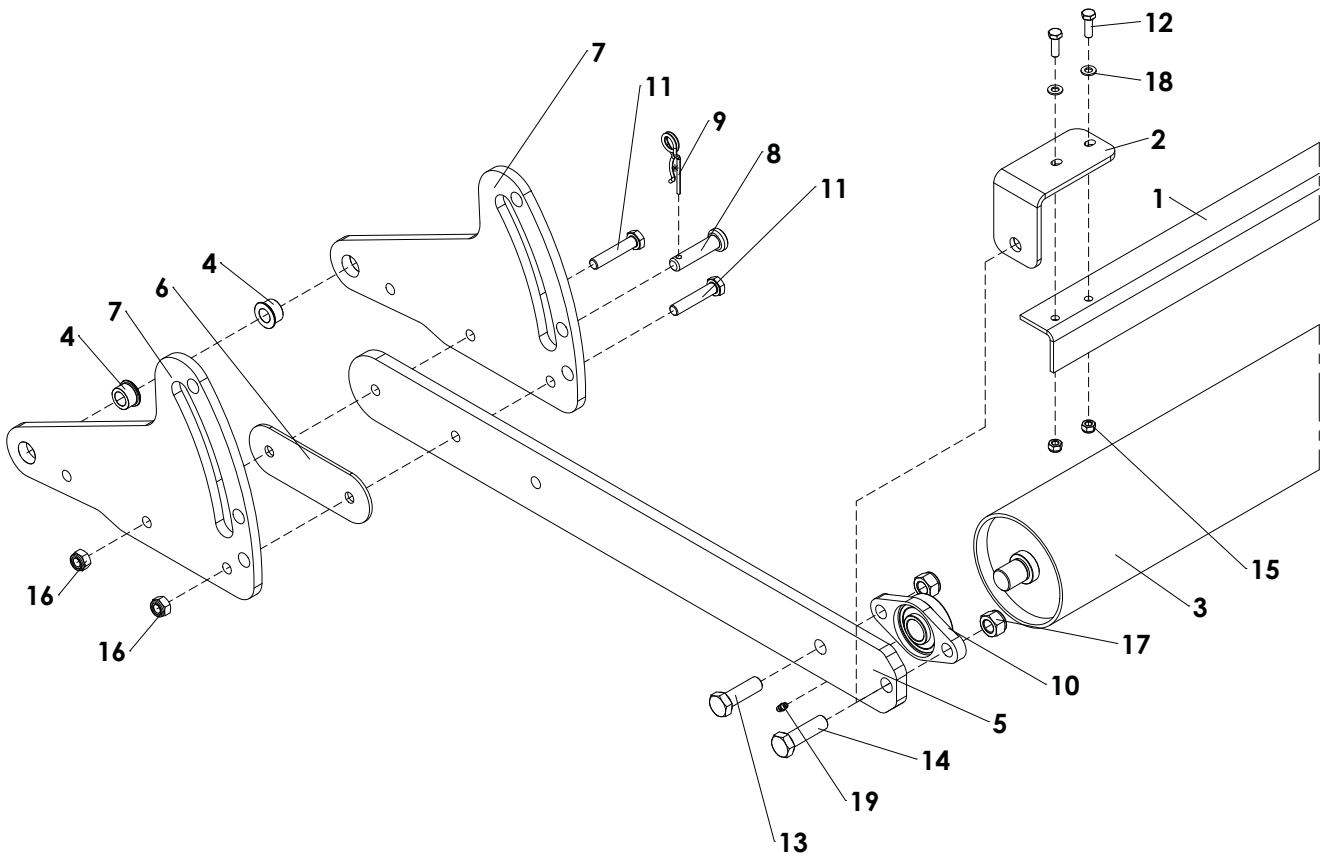

ITEM	PART NUMBER	DESCRIPTION	REMARKS	QUA
1	2283274	Scraper VD7526		1
2	2283276	Rear roller scraper support		2
3	2344424	Rear roller 7526		1
4	404.160.160	Pivot bush		4
5	464.158.200	Second rear roller support		2
6	468.031.800	Distance plate		2
7	468.123.700	Main Rear Roller support		4
8	521.160.510	Lock pin rear roller		2
9	523.030.750	R-Clip Round 3, DIN 11024		2
10	742.250.360	Bearing UCFL 205		2
11	802.120.600	Bolt M12 x 60 - ISO 4014		4
12	804.080.250	Bolt M8 x 25 - ISO 4017		4
13	804.160.500	Bolt M16 x 50 - ISO 4017		2
14	804.160.550	Bolt M16 x 55 - ISO 4017		2
15	830.080.080	Self Lock Nut M8 - ISO 10511		4
16	830.120.120	Self Lock Nut M12 - ISO 10511		4
17	830.160.160	Self Lock Nut M16 - ISO 10511		4
18	864.080.030	Washer M8 - ISO 7089		4
19	880.060.100	Grease nipple M6 DIN 71412A		2

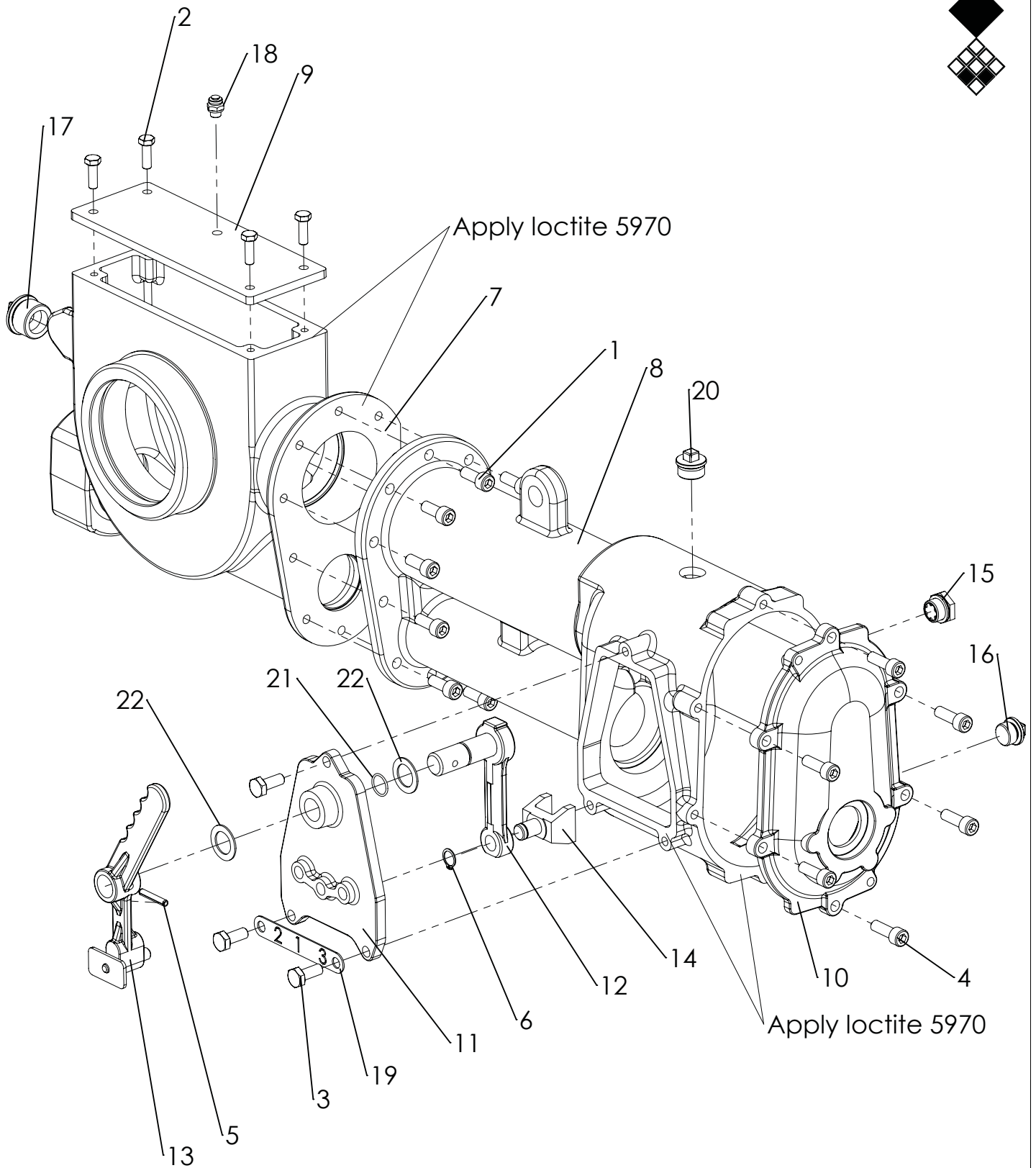

ITEM	PART NUMBER	DESCRIPTION	REMARKS	QUA
1	814.100.250	Bolt M10 x 25 - DIN 912		10
2	804.080.250	Bolt M8 x 25 - ISO 4017		4
3	804.100.250	Bolt M10 x 25 - ISO 4017		3
4	814.100.300	Bolt M10 x 30 - DIN 912		6
5	878.060.350	Roll Pin 6 x 35 - ISO 8752		1
6	870.015.100	Circlip d=15 - DIN 471		1
7	2401410	Front part gearbox		1
8	2401409	Gearbox back		1
9	2471418	Top cover gearbox		1
10	2471856	Gearbox backcover		1
11	2471431	Cover lever		1
12	2469210	Lever with pin		1
13	1994002	Gear lever complete		1
14	2779970	Fork		1
15	820.210.180	Level / fill glass		1
16	4561000	Tap 1/2"		1
17	4561100	Tap 1"		1
18	4067008	Breather gearbox		1
19	468.021.462	Gear indicator		1
20	856.240.240	Gas cap 3/4"		1
21	4422075	O-ring D18.77x1.78		1
22	2894040	Plastic washer 22.2x34x1.5		2
		Use oil 80W90		5.8 Ltr
	1441830-60	Gearbox complete 7516		
	1441830-45	Gearbox complete 7521		
	1441830-36	Gearbox complete 7526		

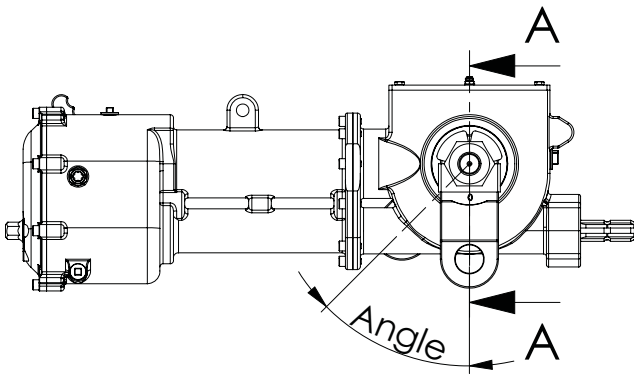

Angle:

- Verti-Drain 7516 - 60°
- Verti-Drain 7521 - 45°
- Verti-Drain 7526 - 36°

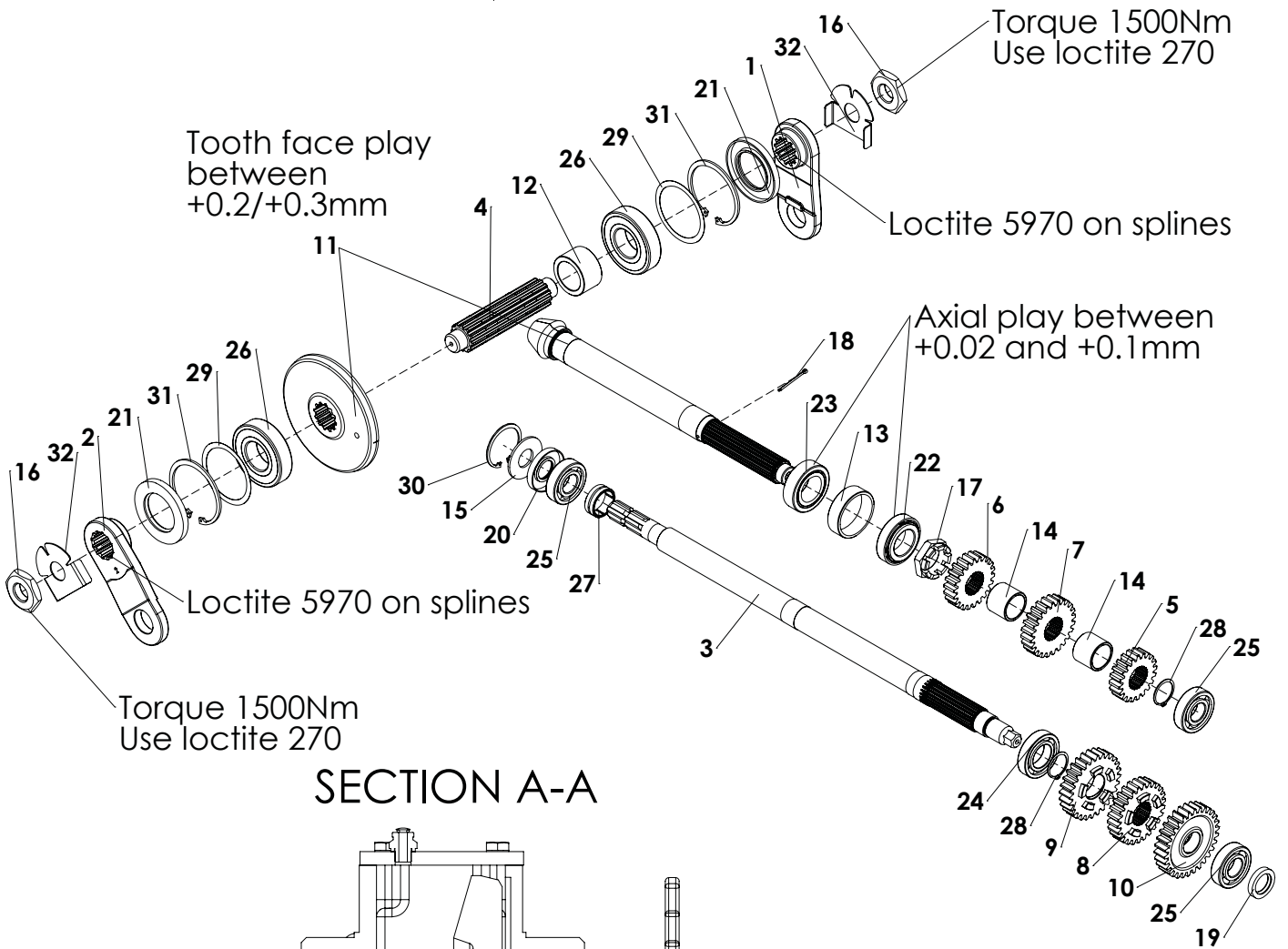

SECTION A-A

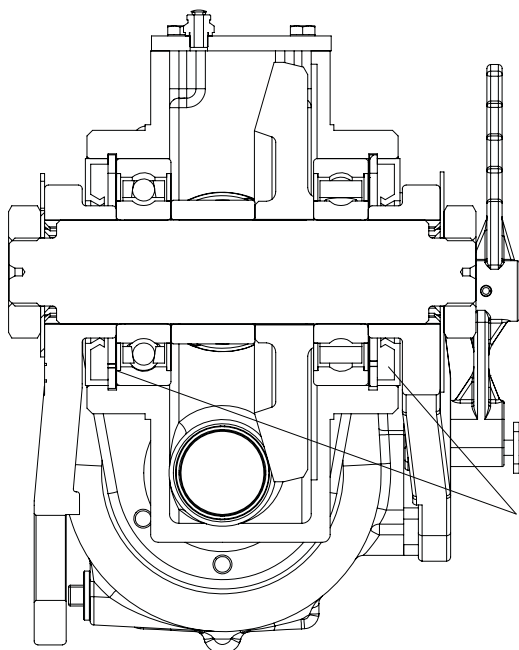

Fill area between seal and bearing complete with a NLGI 2-3 bearing grease. Also apply grease between shaft and seal before assembly.

ITEM	PART NUMBER	DESCRIPTION	REMARKS	QUA
1	2447810	Right hand crank 7516-21-26		1
2	2447812	Left hand crank 7521		1
	2447814	Left hand crank 7526		1
	2447810	Left hand crank 7516		1
3	2460800	Input shaft		1
4	2462100	Splined shaft		1
5	2504450	Gear Z20-m4.25		1
6	2504473	Gear Z22-m4.25		1
7	2504495	Gear Z24-m4.25		1
8	2504512	Gear Z26-m4.25		1
9	2504533	Gear Z28-m4.25		1
10	2504551	Gearwheel Z=30		1
11	2527405	Crownwheel and pignon		1
12	2611404	Distance bush		1
13	2611600	Centering bush		1
14	2612800	Distance bush		2
15	2661490	Washer		1
16	4109300	Nut M36x3		2
17	4135200	Castle Nut		1
18	4317460	Cotter Pin 4 x 56 - DIN 94		1
19	4406260	Oil Seal 35x56x10		1
20	4406460	Oil seal 35x80x12		1
21	4409540	Oil seal 70x120x12		2
22	4810490	Bearing 32210		1
23	4811170	Bearing 33210		1
24	4815270	Bearing 6209		1
25	4816910	Bearing 6307		3
26	713.550.290	Bearing 6311-2RS		2
27	4819215	Bearing NK45/20		1
28	870.045.180	Circlip DIN 471 - 45 x 1.75		2
29	869.120.002	Set of shims 100x120 5x0.1 2x0.3		1
30	872.080.250	Circlip D=80 - DIN 472		1
31	872.120.400	Circlip D=120 - DIN 472		2
32	2282200	Lock plate		2

Solid tines							7526
Mountig Ø (mm)	Tine Size (mm)	Tine Size (inch)	Part #	Adapter			Qua
5	5 x 125	3/16 x 5	311.105.125	J or multi-tine block mini			40+J
8	8 x 150	5/16 x 6	311.108.150	K or multi-tine block			40+K or 80+N+U+W
8	8 x 175	5/16 x 7	9990056	K or multi-tine block			40+K or 80+N+U+W
8	8 x 250	5/16 x 10	9990059	K - Don't use in MTH. Will bend			40+K
12	12 x 150	1/2 x 6	311.112.150				40
12	12 x 200	1/2 x 8	311.112.200				40
12	12 x 225	1/2 x 9	311.112.225				40
12	12 x 250	1/2 x 10	2381837				40
12	12 x 300	1/2 x 12	2381838				40
18	18 x 200	3/4 x 8	311.118.200	L or non needed			20+L
18	18 x 225	3/4 x 9	311.118.225	L or non needed			20+L
18	18 x 250	3/4 x 10	2381841	L or non needed			20+L
18	18 x 300	3/4 x 12	2382638	L or non needed			20+L
18	18 x 350	3/4 x 14	311.118.350	L or non needed			20+L
18	18 x 400	3/4 x 16	2382639	L or non needed			20+L
24	24 x 225	1 x 9	311.124.225				20
24	24 x 350	1 x 14	311.124.350				20
24	24 x 400	1 x 16	2382640				20
Hollow tines							7526
Mountig Ø (mm)	Tine Size (mm)	Tine Size (inch)	Part #	Adapter			Qua
8	10 x 6 x 80	3/8 x 1/4 x 3	311.210.080	K or multi-tine block			40+K or 80+N+U+W
8	10 x 6 x 125	3/8 x 1/4 x 5	311.210.127	K or multi-tine block			40+K or 80+N+U+W
12	16 x 10 x 150	5/8 x 3/8 x 6	311.216.150				40
12	16 x 10 x 175	5/8 x 3/8 x 7	9990022				40
12	19 x 12 x 150	3/4 x 1/2 x 6	311.219.150				40
18	19 x 12 x 200	3/4 x 1/2 x 8	311.219.200	L or non needed			20+L
12	19 x 12 x 200	3/4 x 1/2 x 8	311.219.201				40
18	19 x 12 x 225	3/4 x 1/2 x 9	311.219.225	L or non needed			20+L
12	19 x 12 x 225	3/4 x 1/2 x 9	311.219.226				40
12	19 x 12 x 250	3/4 x 1/2 x 10	9990040				40
18	19 x 12 x 250	3/4 x 1/2 x 10	9990023	L or non needed			20+L
18	25 x 16 x 200	1 x 5/8 x 8	311.225.200	L or non needed			20+L
18	25 x 16 x 225	1 x 5/8 x 9	311.225.225	L or non needed			20+L
18	25 x 17 x 250	1 x 5/8 x 10	9990024	L or non needed			20+L
18	29 x 19 x 250	1 1/8 x 3/4 x 10	9990066	L or non needed			20+L
24	32 x 21 x 300	1 1/4 x 13/16 x 12	9990034				20
18	32 x 21 x 300	1 1/4 x 13/16 x 12	9990041	L or non needed			20+L
Replacement tubes							7526
Mountig Ø (mm)	Tine Size (mm)	Tine Size (inch)	Part #	Combine with rollpin			Qua
12	16 x 10 x 150	5/8 x 3/8 x 6	311.716.150	9990010			
12	16 x 10 x 175	5/8 x 3/8 x 7	9990036	9990010			40
12	19 x 12 x 150	3/4 x 1/2 x 6	311.719.150	9990012			
18	19 x 12 x 200	3/4 x 1/2 x 8	311.719.200	9990012			
12	19 x 12 x 200	3/4 x 1/2 x 8	311.719.200	9990012			
18	19 x 12 x 225	3/4 x 1/2 x 9	311.719.225	9990012			
12	19 x 12 x 225	3/4 x 1/2 x 9	311.719.225	9990012			
12	19 x 12 x 250	3/4 x 1/2 x 10	9990037	9990012			40
18	19 x 12 x 250	3/4 x 1/2 x 10	9990037	9990012			
18	25 x 16 x 200	1 x 5/8 x 8	311.725.200	9990014			
18	25 x 16 x 225	1 x 5/8 x 9	311.725.225	9990014			20
18	25 x 17 x 250	1 x 5/8 x 10	9990038	9990014			
18	29 x 19 x 250	1 1/8 x 3/4 x 10	9990067	9990016			20
24	32 x 21 x 300	1 1/4 x 13/16 x 12	9990039	9990016			
18	32 x 21 x 300	1 1/4 x 13/16 x 12	9990039	9990016			
Cross tines							7526
Mountig Ø (mm)	Tine Size (mm)	Tine Size (inch)	Part #	Adapter			Qua
8	12 x 90	1/2 x 3 1/2	9990020	K or multi-tine block			40 + K
12	12 x 90	1/2 x 3 1/2	311.812.090				
12	19 x 120	3/4 x 5	9990021				40
Chisel tines							7526
Mountig Ø (mm)	Tine Size (mm)	Tine Size (inch)	Part #				Qua
12	4.8 x 19 x 175	3/16 x 3/4 x 7	311.619.175				40
12	4.8 x 19 x 120	3/16 x 3/4 x 4 3/4	311.619.120				40
19	5 x 30 x 90	3/16 x 1 3/16 x 3 1/2	311.619.127	Tines for verti-core			
Composed hollow tines							7526
Shank		Size (mm)	Size (inch)	Part #			Qua
A	12	12	1/2	311.120.690	(Straight)		40
B	18	18	3/4	311.180.782	(Straight)		20
C	12	12	1/2	311.180.780			40
D	24	24	1	311.240.862	(Straight)		20
E	18	18	3/4	311.240.860			
Clip		Size (mm)	Size (inch)	Part #			Qua
F	16	16	5/8	438.160.160			40
G	22	22	7/8	438.220.220			40 / 20
H	30	30	1 3/16	438.300.300			20
Hollow tine tube (folded)							7526
		Tine Size (mm)	Tine Size (inch)	Part #			Qua
		16 x 150	5/8 x 6	317.316.150	Combine with:	A and F	40A+40F
		16 x 200	5/8 x 8	317.316.200	Combine with:	A and F	40A+40F
		22 x 150	7/8 x 6	317.322.150	Combine with:	B or C and G	40B+40G+40L
							40C+40G
		22 x 250	7/8 x 10	317.322.250	Combine with:	B or C and G	40B+40G+40L
							40C+40G
		22 x 150	7/8 x 6	317.322.150	Combine with:	B or C and G	20B+20G+20L
							20C+20G
		22 x 250	7/8 x 10	317.322.250	Combine with:	B or C and G	20B+20G+20L
							20C+20G
		30 x 150	1 3/16 x 6	317.330.150	Combine with:	E and H	20D+20H
							20E+20H+20L
		30 x 225	1 3/16 x 9	317.330.220	Combine with:	E and H	20D+20H
							20E+20H+20L
		30 x 300	1 3/16 x 12	317.330.300	Combine with:	E and H	20D+20H

Adapter							7526	
	J	Tine Size (mm)	Tine Size (inch)	Part #			Qua	
		5	3/16	314.205.043			40	
	K	8	5/16	314.208.043			40	
Adapter							7526	
	L	Tine Size (mm)	Tine Size (inch)	Part #			Qua	
		18	3/4	2451800			20	
Multi-tine block complete WO tines							7526	
		Tine Size (mm)	Tine Size (inch)	Part #		Tines:	Qua	
		8mm (5 tines)	5/16	211.700.016	Combination of:	T-O-U-Y-Z	A1-A3-A4-A5	
		8mm (6 tines)	5/16	9990206	Combination of:	M-U	A1-A2-A3-A4-A5	
		8mm (8 tines)	5/16	9990208	Combination of:	N-U	A1-A2-A3-A4-A5	
		8mm (8 tines)	5/16	9990211	Combination of:	N-U-W	A1-A2-A3-A4-A5	10 (80 tines)
		8mm (8 tines)	5/16	314.430.209	Combination of:	P-U	A1-A2-A3-A4-A5	
		Tines:						
		A1	8 x 150	5/16 x 6	311.108.150	Solid tine		
		A2	8 x 175	5/16 x 7	9990056	Solid tine		
		A3	10 x 6 x 80	3/8 x 1/4 x 3	311.210.080	Hollow tine		
	A4	10 x 6 x 125	3/8 x 1/4 x 5	311.210.127	Hollow tine			
	A5	12 x 90	1/2 x 3 1/2	9990020	Cross tine			
Multi-tine block empty							7526	
		Tine Size (mm)	Tine Size (inch)	Part #			Qua	
	M	8mm (6 tines)	5/16	9990201				
	N	8mm (8 tines)	5/16	314.430.240			10	
	O	8mm (5 tines)	5/16	480.301.430				
	P	8mm (8 tines)	5/16	211.215.002				
Tine lock bolt							7526	
		Size (mm)		Part #			Qua	
	U	10x40		812.100.401				
		10x35		4001675			80	
Stud							7526	
		Size (mm)		Part #			Qua	
	W	23.2x50		408.230.500			20	
	X	12x60		9990212D				
Turf hold down fingers							7526	
		Part name				Part #	Qua	
		Turf hold down finger						
		Turf hold down finger MTH						
		Turf hold down finger 12mm end						
		Turf hold down finger 12mm					311.510.250	10
		Turf hold down finger 18mm						
		Turf hold down finger 24mm end					311.510.252	10
	Turf hold down finger 24mm							
Turf hold down kit							7526	
		Part name				Part #	Qua	
		THD kit complete						
		THD kit complete MTH						
		THD kit complete 12mm					211.752.009	1
		THD kit complete 18mm						
		THD kit complete 24mm					211.752.008	1

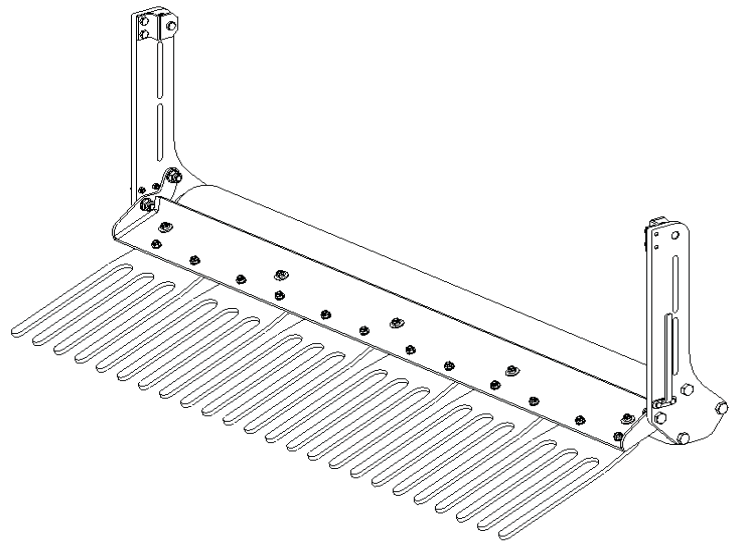

Optional: Auxiliary spring kit

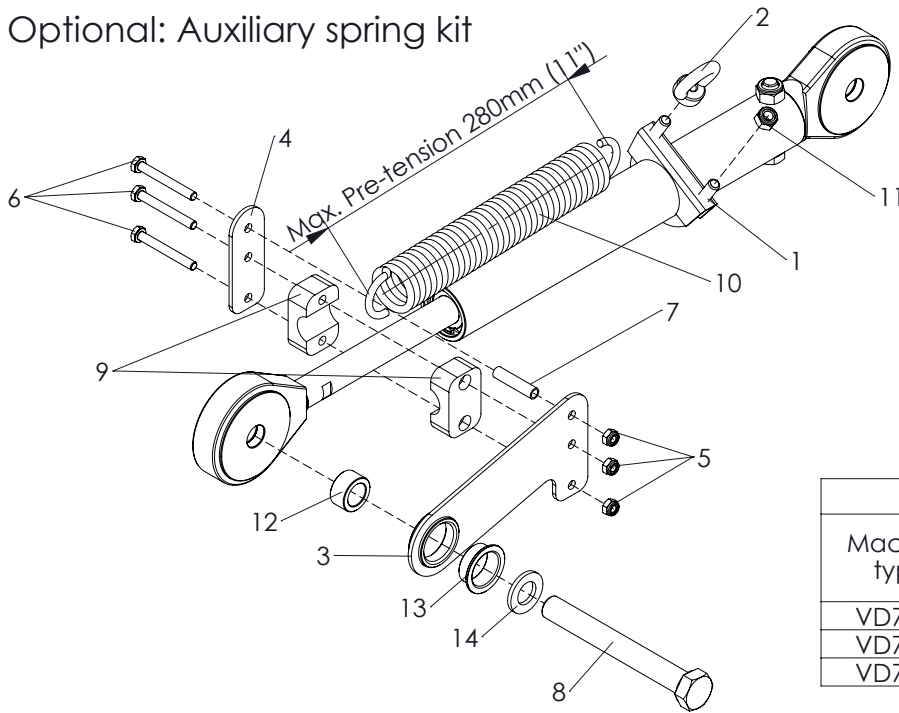

Combination table		
Machine type	Quantity 211.752.004	Quantity 211.752.005
VD7516	5	1
VD7521	7	1
VD7526	9	1

ITEM	PART NUMBER	DESCRIPTION	REMARKS	QUA
1	547.080.700	Pipe clamp Ø42		1
2	822.080.360	Lifting Eye Nut M8 - DIN 582		1
3	468.031.650	Holder plate		1
4	468.030.808	Contra plate		1
5	830.060.060	Self Lock Nut M6 - ISO 10511		3
6	802.060.500	Bolt M6 x 50 - ISO 4014		3
7	542.080.035	Tube		1
8	802.161.300	Bolt M16 x 130 - ISO 4014		1
9	547.200.302	Pipe clamp single Ø20 Gr3		1
10	575.302.252	Spring auxiliary kit VD		1
11	830.080.080	Self Lock Nut M8 - ISO 10511		1
12	410.170.130	Bearing bush		1
13	733.250.120	Bearing		1
14	864.160.030	Washer M16 - ISO 7089		1
15	211.752.004	Auxiliary spring kit 75 series	Contains item 1-14. Quantity per machine see Combination table	

Lock strip kit: 1 needed to apply auxiliary spring kit on most right side of machine.

Drill hole Ø10.5 (0.41")
Use 464.031.050 Lock plate as a template

Assembled situation right side machine

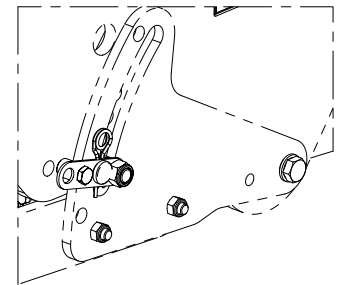
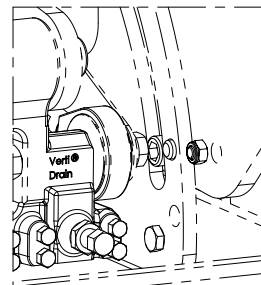
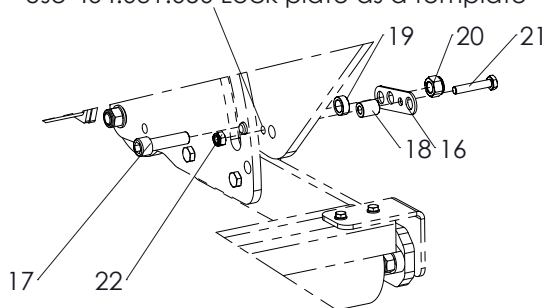

ITEM	PART NUMBER	DESCRIPTION	REMARKS	QUA
15	211.752.004	Auxiliary spring kit 75 series		1
16	464.031.050	Lock plate		1
17	814.160.600	Bolt M16 x60 - DIN 912		1
18	402.100.250	Distance bush Ø20/Ø11 L=25		1
19	406.160.102	Distance bush		1
20	830.160.160	Self Lock Nut M16-ISO 10511 Class 10		1
21	802.100.550	Bolt M10 x 55 - ISO 4014		1
22	830.100.100	Self Lock Nut M10 - ISO 10511		1
	211.752.005	Lock strip kit	Contains item 15-22. Quantity per machine see Combination table	



Rear roller support replacement strip

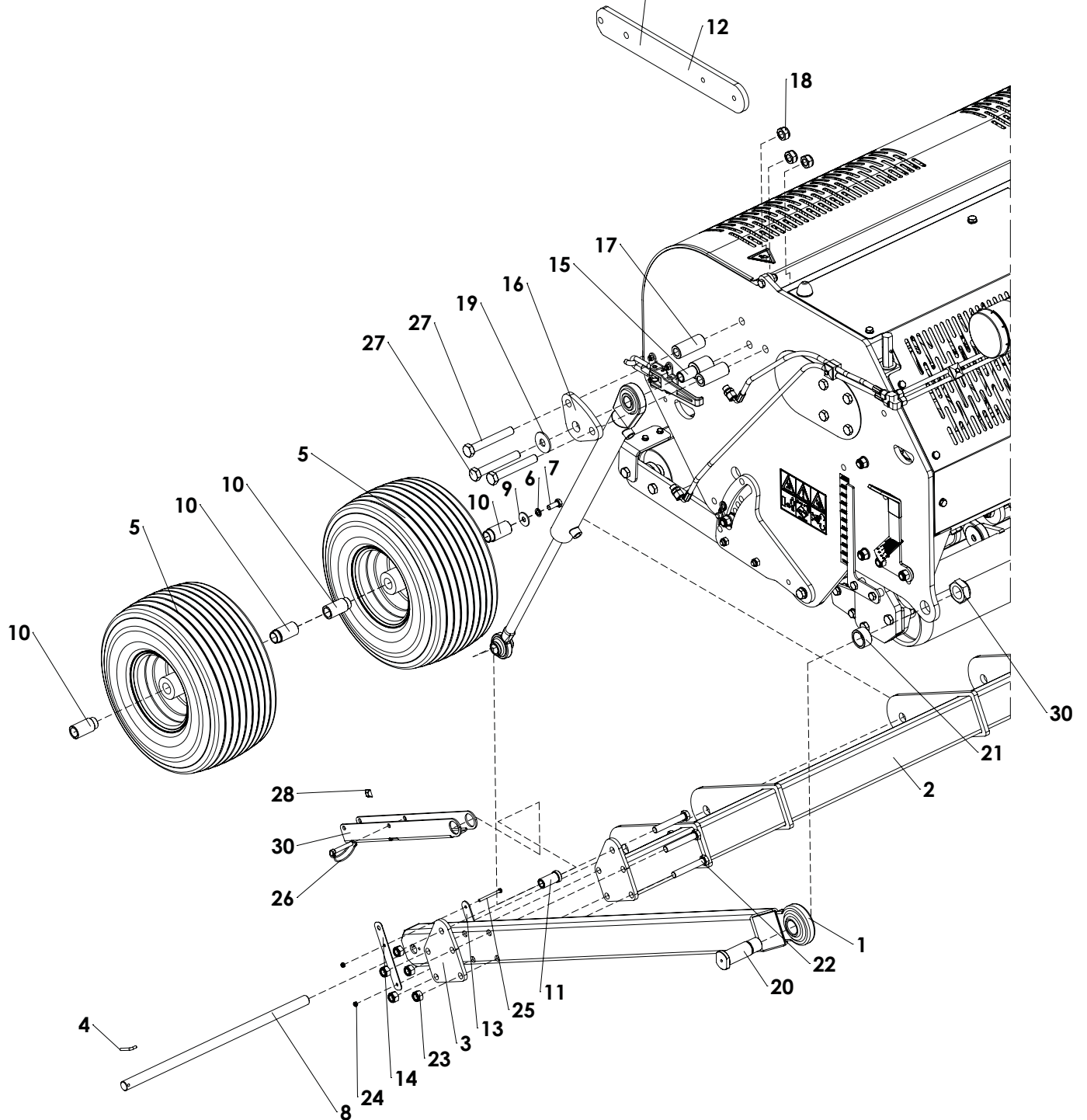

Redexim Verti-Drain 7516/7521/7526 optional wheel kit Page 15-1 Code 1626

ITEM	PART NUMBER	DESCRIPTION	REMARKS	QUA VD7516	QUA VD7521	QUA VD7526
1	494.167.010	Side support		2	2	2
2	494.176.042	Rear wheel support 7516	VD 7516	1	0	0
	494.228.042	Rear wheel support 7521	VD 7521	0	1	0
	494.279.042	Rear wheel support 7526	VD 7526	0	0	1
3	468.101.680	Cylinder plate		2	2	2
4	2499186	Lock pin		2	2	2
5	511.542.236	Wheel Complete		4	4	4
6	866.120.020	Spring Washer M12 - DIN 127		2	2	2
7	804.120.300	Bolt M12 x 30 - ISO 4017		2	2	2
8	2499188	Wheel shaft		2	2	2
9	864.120.031	Large washer M12 - DIN 9021		2	2	2
10	404.250.700	Distance Bush Wheel		4	4	4
11	2611938	Distance bush		2	2	2
12	464.155.700	Second rear roller support short	Replace standaard rear roller support (464.158.200)	2	2	2
13	468.031.370	Strip 30x3 L=137		2	2	2
14	577.016.185	Hook up plate 75H lock		2	2	2
15	404.210.970	Cylinder bush		2	2	2
16	468.151.702	Bridge plate		2	2	2
17	406.210.850	Distance bush Ø35/Ø20.5 L=85		4	4	4
18	830.200.200	Self Lock Nut M20 Din 985 h=17		6	6	6
19	864.200.041	Large washer M20 - DIN 9021		2	2	2
20	416.381.250	Pivot shaft		2	2	2
21	406.380.250	Distance bush Ø50/Ø37.7 L=25		2	2	2
22	802.161.000	Bolt M16 x 100 - ISO 4014		10	10	10
23	830.160.160	Self Lock Nut M16-ISO 10511 Class 10		10	10	10
24	830.060.060	Self Lock Nut M6 - ISO 10511		4	4	4
25	802.060.700	Bolt M6 x 70 - ISO 4014		4	4	4
26	523.100.700	Pipe linch pin Ø10		2	2	2
27	802.201.400	Bolt M20 x 140 - ISO 4014		6	6	6
28	572.080.200	Self adhesive buffer		6	6	6
29	468.045.100	Lock beam 75 H models		1		
30	4129210	Nut M35x1.5		2	2	2
	211.751.600	Complete boggy kit 7516				
	211.752.104	Complete boggy kit 7521				
	211.752.600	Complete boggy kit 7526				

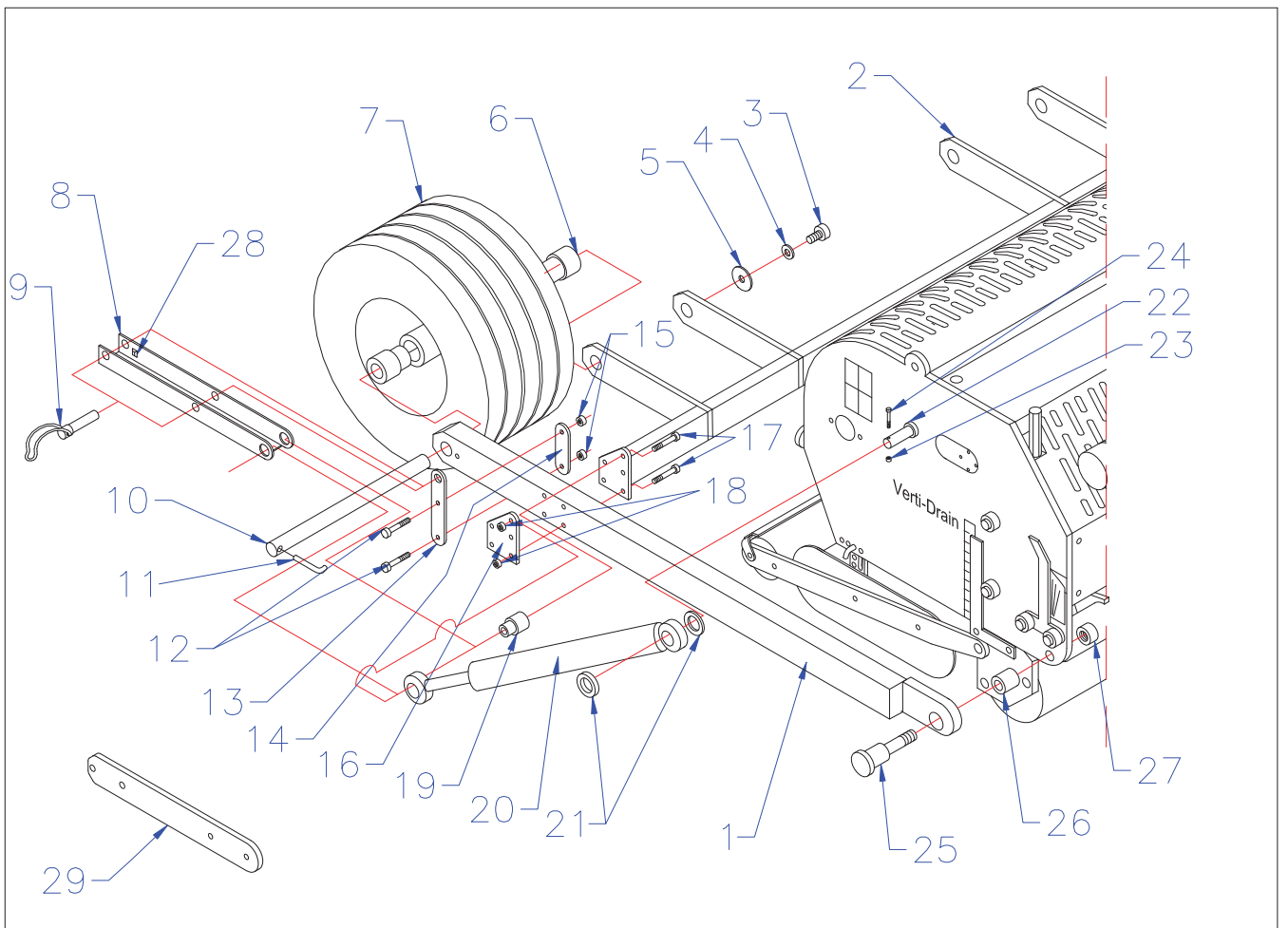

Redexim-Charterhouse Verti-Drain 7516/7521/7526 Wheel kit page 15 code 0920

	PART# 7516	PART# 7521	PART# 7526	DESCRIPTION	REMARKS	QUA
1	2283292	Same	Same	Side support		2
2	2283280	2283282	2283284	Rear wheel support		1
3	802.120.300	Same	Same	Bolt M12 x 30		2
4	866.120.020	Same	Same	Spring washer M12		2
5	864.120.030	Same	Same	Washer M12		2
6	2611934	Same	Same	Distance bush wheel		8
7	511.542.236	Same	Same	Wheel		4
8	468.045.100	Same	Same	Lock beam 75 H models		2
9	523.100.700	Same	Same	Pipe linch pin		2
10	2499188	Same	Same	Wheel shaft		2
11	2499186	Same	Same	Lock pin		2
12	802.060.700	Same	Same	Bolt M6 x 70		4
13	577.016.185	Same	Same	Hook up plate 75 H lock		2
14	468.031.370	Same	Same	Mount plate 75 H lock		2
15	830.060.060	Same	Same	Self lock nut M6		4
16	2283286	Same	Same	Lock Plate		2
17	802.161.000	Same	Same	Bolt M16 x 100		10
18	830.160.160	Same	Same	Self lock nut M16		10
19	2611938	Same	Same	Distance bush cylinder		2
20	1811312	Same	Same	Cylinder		2
21	864.300.055	Same	Same	Washer M30		8
22	2490888	Same	Same	Three point link pin		3
23	830.100.100	Same	Same	Self lock nut M10		2
24	802.100.400	Same	Same	Bolt M10 x 40		2
25	2499184	Same	Same	Pin		2
26	2611936	Same	Same	Bush		2
27	830.220.220	Same	Same	Self lock nut M22		2
28	572.080.200	Same	Same	Self adhesive buffer		8
29	464.155.700	Same	Same	Second rear roller supp. short		2

Optional top-drawbar

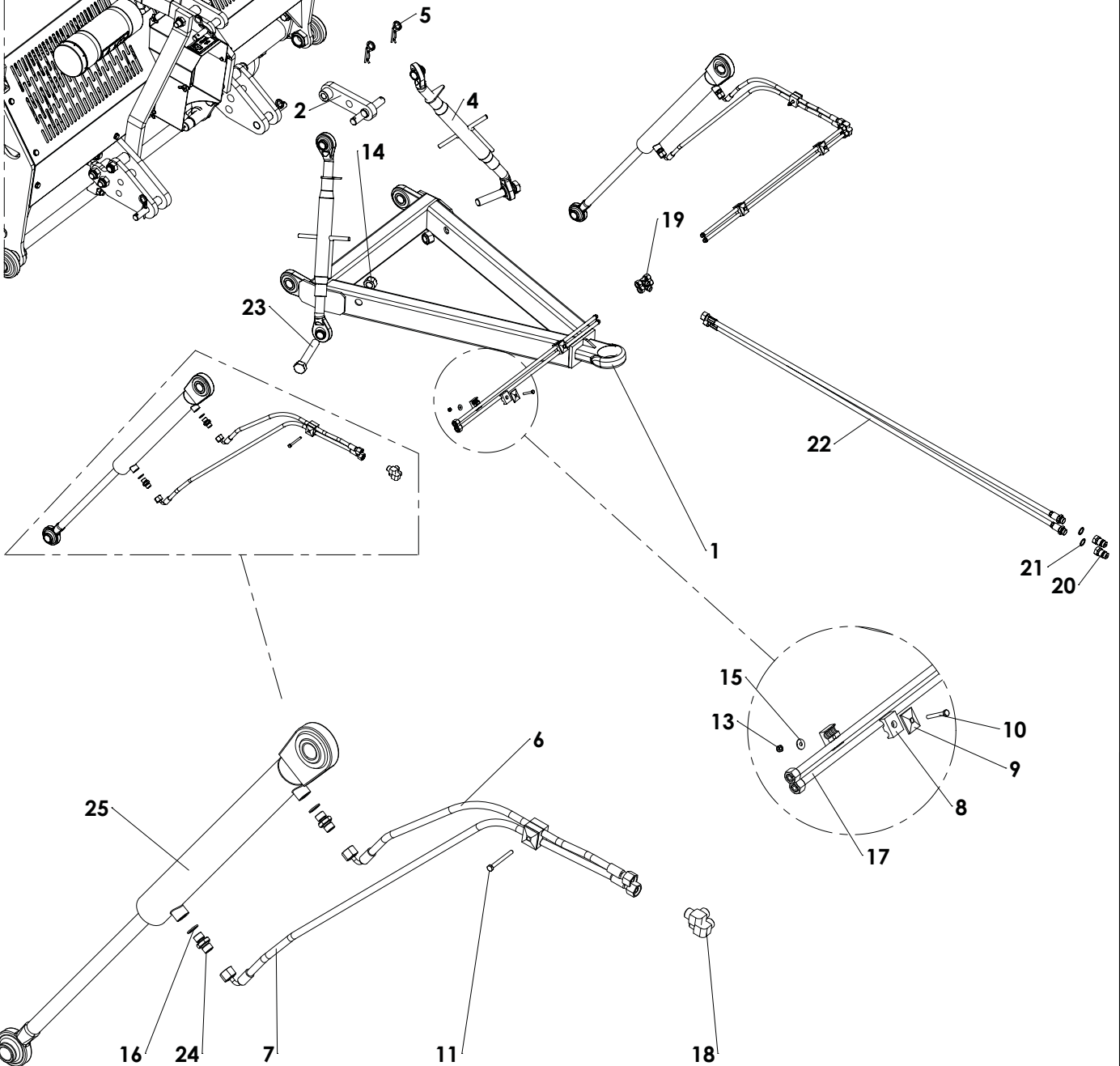
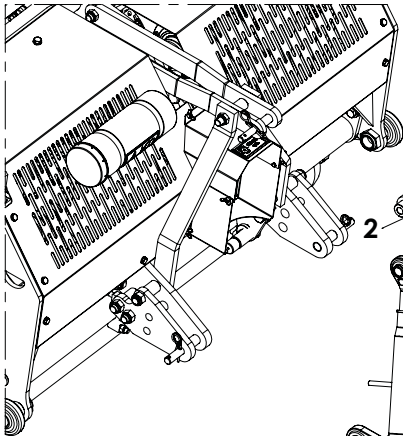
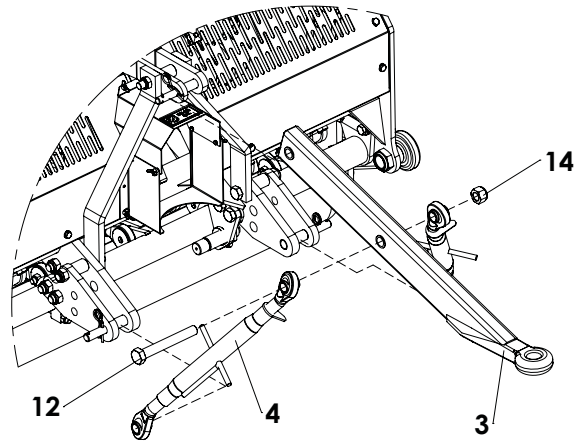

Redexim Verti-Drain 7516/7521/7526 optional wheel kit Page 16-1 Code 2134

ITEM	PART NUMBER	DESCRIPTION	REMARKS	QUA VD7516	QUA VD7521	QUA VD7526
1	2283288	Draw bar	VD 7516	1	0	0
	2283290	Draw bar	VD 7521 + VD 7526	0	1	1
2	2283294	Top link support		1	1	1
3	462.101.070	Top draw bar	Optional	1	1	1
4	522.256.200	Toplink Cat. 1 L0=555 Stroke=200 UNC 1 1/4"		2	2	2
5	523.051.000	R-clip Round 5, DIN 11024		2	2	2
6	541.130.680	Hose NSK 6 (1/4") TL=680 PF6690 + PGLO618		2	2	2
7	541.131.090	Hose NSK 6 (1/4") TL=1135 PF6690 + PGLO618		2	2	2
8	547.120.120	Hose clamp double 12mm		12	12	12
9	547.300.340	Cover plate hose clamp 2x10 - 2x12		6	6	6
10	802.060.450	Bolt M6 x 45 - ISO 4014		4	4	4
11	802.060.600	Bolt M6 x 60 - ISO 4014		2	2	2
12	808.010.070	Hex Bolt 1"-8x7.5" UNC - ANSI B18.2.1	Optional	1	1	1
13	830.060.060	Self Lock Nut M6 - ISO 10511		6	6	6
14	838.010.220	Self Lock Nut 1 inch UNC - DIN 985	Optional for top- drawbar	2 (1)	2 (1)	2 (1)
15	864.060.031	Large washer M6 - DIN 9021		4	4	4
16	874.170.020	Copper washer 3_8		4	4	4
17	542.120.815	Tube for boggy 7516	VD 7516	4	0	0
	542.121.070	Tube 12mm 2xM18 L1070	VD 7521	0	4	0
	542.121.329	Tube 12mm 2xM18 L1330	VD 7526	0	0	4
18	544.120.360	90 degree connector 12L-M18		4	4	4
19	544.124.125	T-Connector 12x12x12		2	2	2
20	545.210.800	Quick connector male 1/2"		2	2	2
21	874.210.020	Copper washer 1_2		2	2	2
22	541.172.510	Main hose 75 serie		2	2	2
23	808.010.060	Hex Bolt 1"-8x6" UNC - ANSI B18.2.1		2	2	2
24	543.170.170	Nipple BSP 3_8" x 3_8" 60deg		4	4	4
25	1811312	Cylinder 50/25 Lo=685 stroke=400		2	2	2

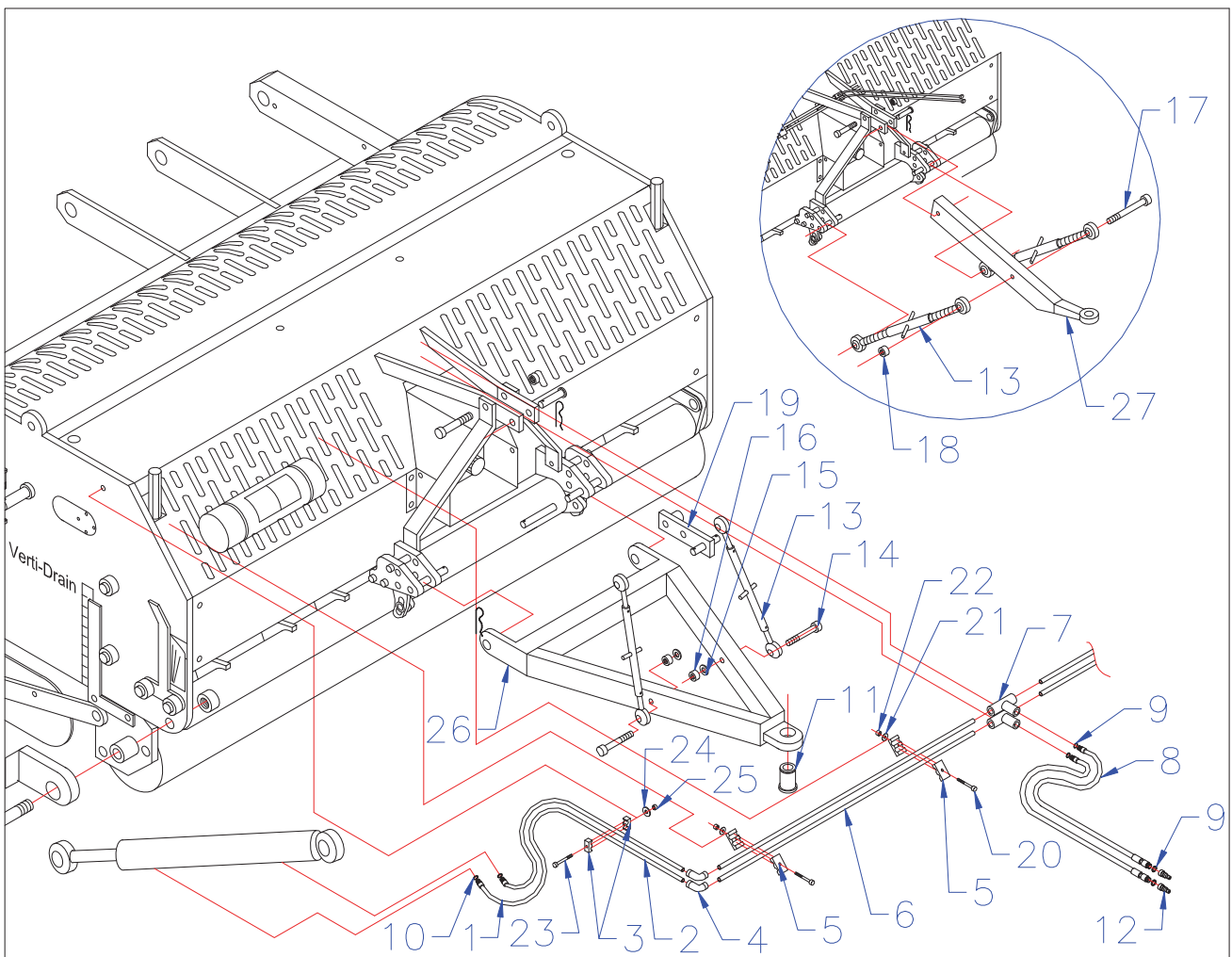

**Redxim-Charterhouse Verti-Drain 7516/7521/7526 page 16 code 1444
Hydraulics & draw rod**

	PART# 7516	PART# 7521	PART# 7526	DESCRIPTION	REMARKS	QUA
1	541.131.090	Same	Same	Hose long 1/4"		2
2	541.130.680	Same	Same	Hose short 1/4"		2
3	547.150.150	Same	Same	Clamp set 15 mm		2
4	544.120.360	Same	Same	90 degrees connector		4
5	547.120.120	Same	Same	Clamp set 12 mm		4
6	542.120.815	542.121.070	542.121.329	Tube 12 mm		4
7	544.124.125	Same	Same	T-connector 12x12x12		2
8	541.172.510	Same	Same	Hose 3/8"		2
9	874.170.020	Same	Same	Copper washer 3/8"		4
10	874.210.020	Same	Same	Copper washer 1/2"		2
11	404.320.550	Same	Same	Pivot bush draw bar		1
12	545.210.800	Same	Same	Quick connector male G 1/2"		2
13	522.256.200	Same	Same	Top link special		2
14	808.010.050	Same	Same	Bolt 1" x 5" UNF		2
15	866.010.050	Same	Same	Spring washer 1"		2
16	838.010.140	Same	Same	Low Nut 1" UNF		2
17	808.010.070	Same	Same	Bolt 1" x 7" UNC		1
18	838.010.220	Same	Same	Nut 1" UNC		1
19	2283294	Same	Same	Top link support		1
20	802.060.450	Same	Same	Bolt M6 x 45		4
21	864.060.021	Same	Same	Large washer M6 x 40		4
22	830.060.060	Same	Same	Self lock nut M6		4
23	802.080.055	Same	Same	Bolt M8 x 55		2
24	864.080.031	Same	Same	Large washer M8 x 35		2
25	830.080.080	Same	Same	Self lock nut M8		2
26	2283288	2283290	2283290	Draw bar		1
27	462.101.070	Same	Same	Top draw bar		1
28	543.170.170	Same	Same	Nipple 3/8" x 3/8"		4

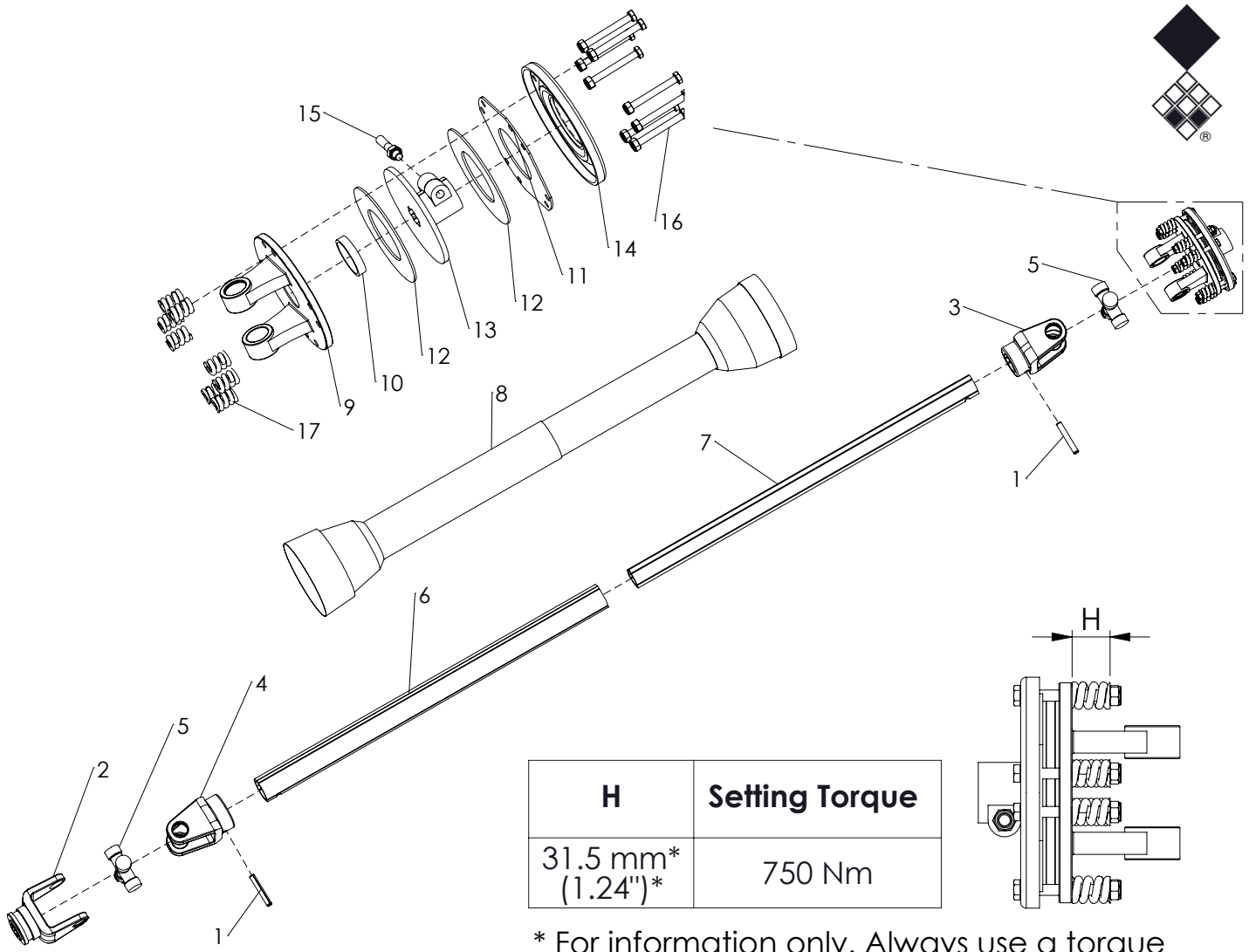

* For information only. Always use a torque test rig to set the correct value.

ALWAYS deburr parts when cut
MEASURE correct length of PTO first
MAINTAIN slipclutch every month
NEVER USE PTO over 30 degrees
SLIPCLUTCH always on machine side

ITEM	PART NUMBER	DESCRIPTION	REMARKS	QUA
1	190.000.271	Inner roll pin		2
2	BEN PT140150	End yoke with quick lock		1
3	BEN PT148826	Inner tube yoke		1
4	BEN PT148827	Outer tube yoke		1
5	BEN PT151040	Universal joint assembled		2
6	BEN PT158168	Tubing cut to size	Cut to correct length	1
7	BEN PT158790	Tubing cut to size	Cut to correct length	1
8	BEN PT166465	Complete shaft shield	Cut to correct length	1
9	BEN F2B08	Flanged yoke		1
10	BEN F060	Bush		1
11	BEN F071	Inner plate		1
12	BEN F31/HP	Lining ring		2
13	BEN F238	Hub		1
14	BEN F2200	Pressure plate		1
15	BEN 90938	Conic bolt and nut		1
16	BEN F10085	Bolt and nut		8
17	BEN F0111	Spring		8
	611.801.200	PTO shaft type T-80 tl 1200		
	611.806.100	PTO shaft type T-80 tl 610		

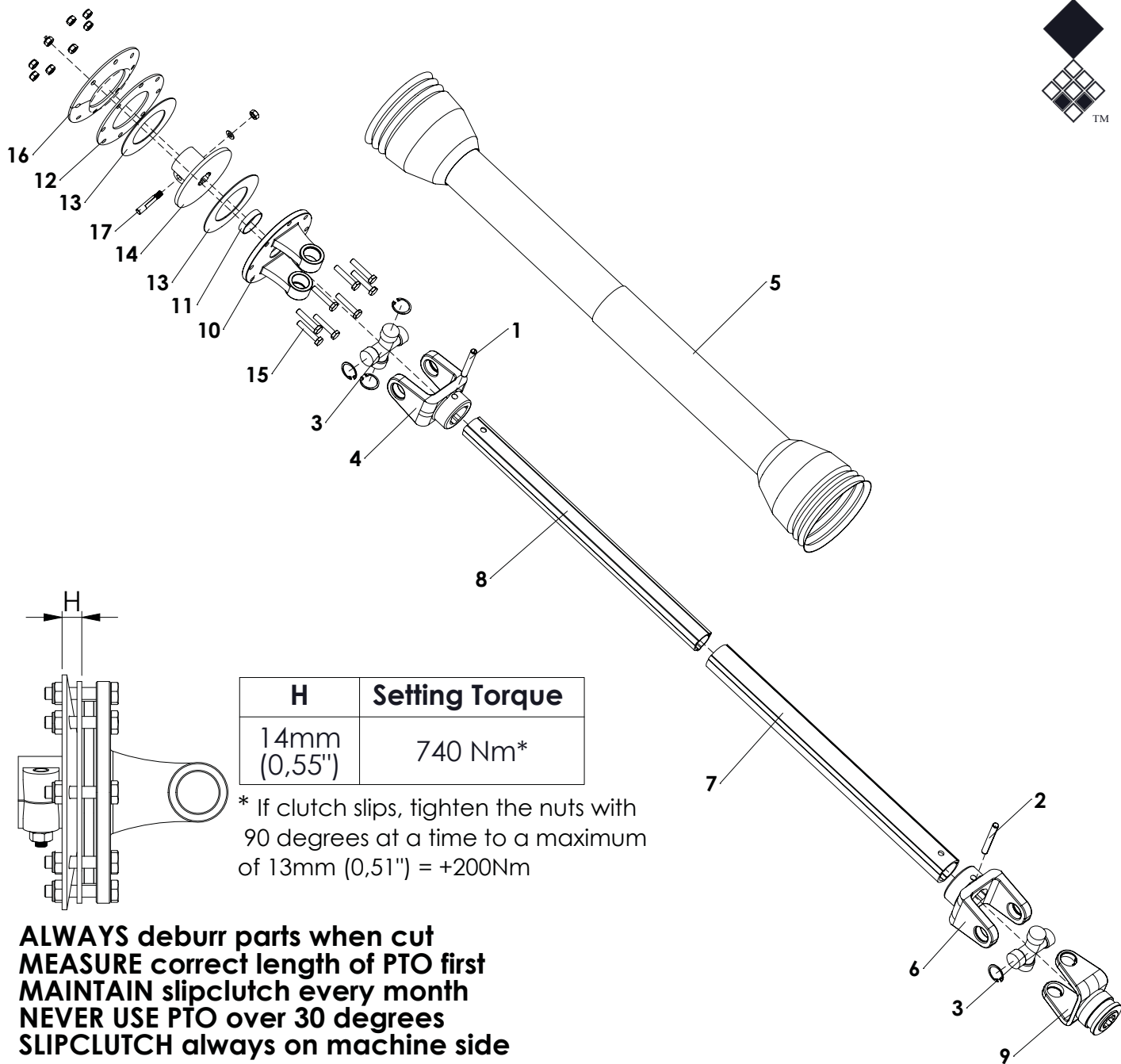

ALWAYS deburr parts when cut
MEASURE correct length of PTO first
MAINTAIN slipclutch every month
NEVER USE PTO over 30 degrees
SLIPCLUTCH always on machine side

ITEM	PART NUMBER	DESCRIPTION	REMARKS	QUA
1	190000271	Inner roll pin		1
2	190000243	Outer roll pin		1
3	180018130	Cross and 4x circlip kit		2
4	1510181341	Inner tube yoke		1
5	1423800167851	Complete shield	Cut to correct length	1
6	1510181331	Outer tube yoke		1
7	1521981490700	T-series Outer tube	Cut to correct length	1
8	153190018	T-series Inner tube	Cut to correct length	1
9	1410284231	Complete collar yoke		1
10	1510180161	Flanged yoke		1
11	180019019	Bush		1
12	180017430	Pressure plate		1
13	180019018	Lining ring		2
14	1510194061	Hub T80		1
15	165000511	Bolt & nut M10x1,5x55		8
16	180017451	Belleville spring		1
17	165000588	Tapered Pin 1 3/8" kit	Retighten every 40 hours	1
	800611	Complete PTO T80		
	811110	Complete PTO T80 for boggy		

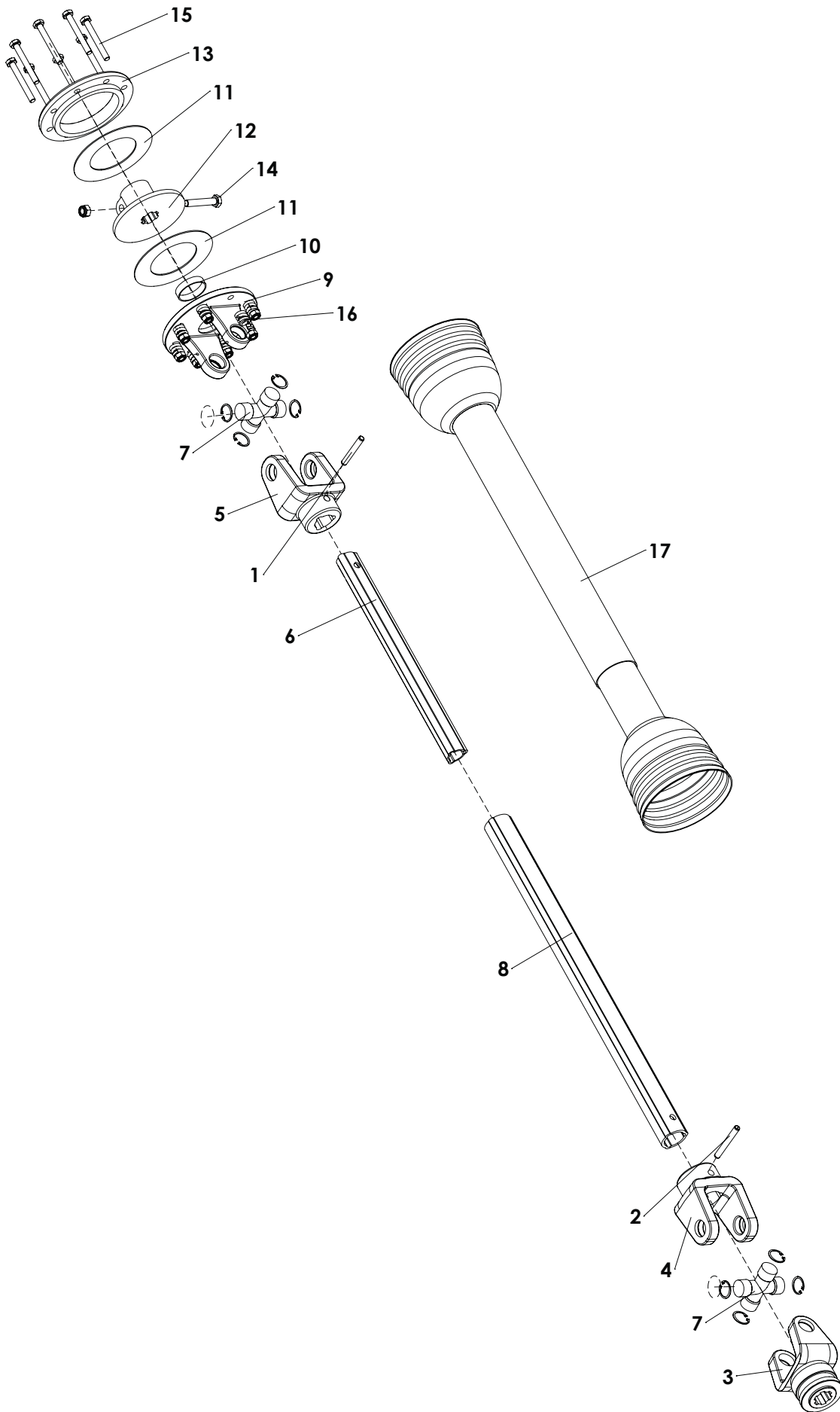

ITEM	PART NUMBER	DESCRIPTION	REMARKS	QUA
1	190000271	Inner roll pin		1
2	190000243	Outer roll pin		1
3	141028080	Complete collar yoke type 80		1
4	151018133	Outer tube yoke type 80		1
5	151018134	Inner tube yoke type 80		1
6	153190005	T80-series Inner tube		1
	153190013	Inner tube towed	With wheel kit	1
7	180018130	Cross and 4x circlip kit		2
8	152198140	T80-series Outer tube		1
	152198146	Outer tube towed	With wheel kit	1
9	151018016	Flanged yoke T80		1
10	180019019	Bush		1
11	180019018	Lining ring		2
12	151018018	Hub		1
13	180019116	Pressure plate		1
14	165000502	Bolt and Nut	Retighten every 40 hours	1
15	165000501	Bolt and nut		8
16	180014022	Spring		8
17	1422600097930	Complete guard 80-seriesComplete	Cut to correct length	1
	1422600097930	guard 80-series towed	With wheel kit	1
	800611	Complete PTO T80		
	811110	Complete PTO T80 for bogey		
		ALWAYS deburr parts when cut		
		MEASURE correct length of PTO first		
		MAINTAIN slipclutch every month		
		NEVER USE PTO over 30 degrees angle		
		SLIPCLUTCH always on machine side		