

VERTI-DRAIN 2519

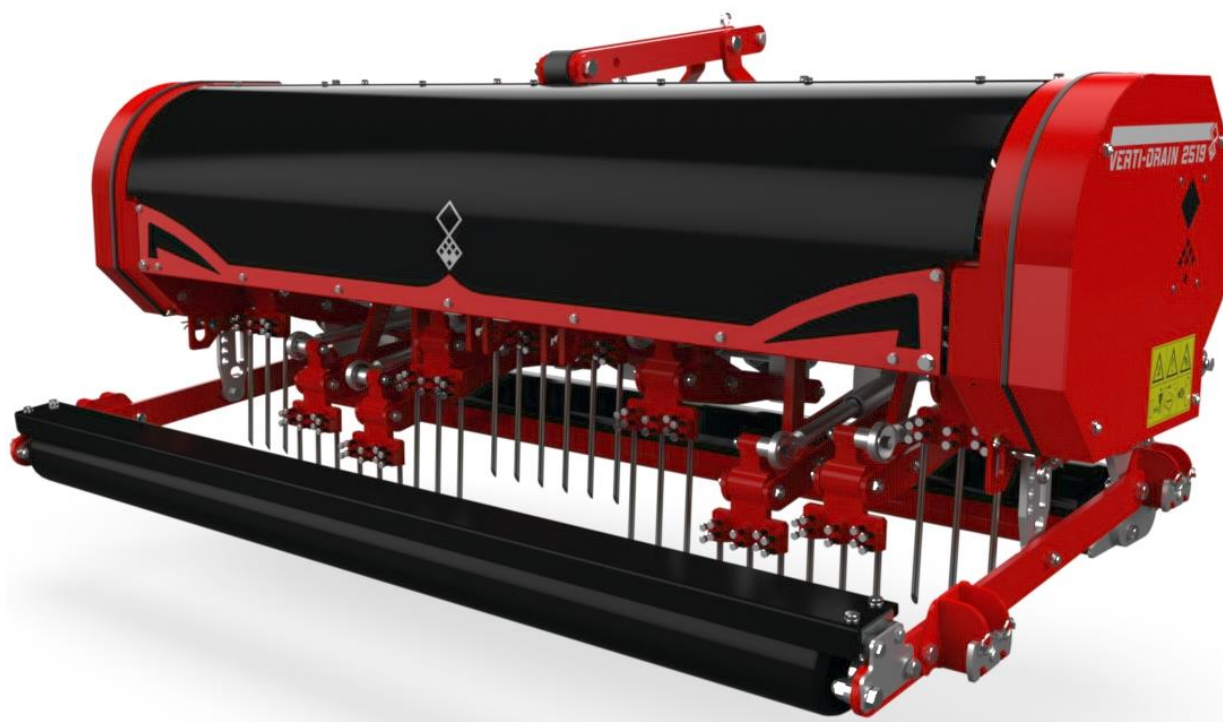

Version: 2434

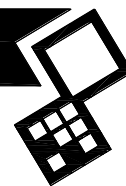

Kwekerijweg 8 | 3709JA | Zeist | The Netherlands |
T: +31 (0)306 933 227
E: redexim@redexim.com
W: www.redexim.com

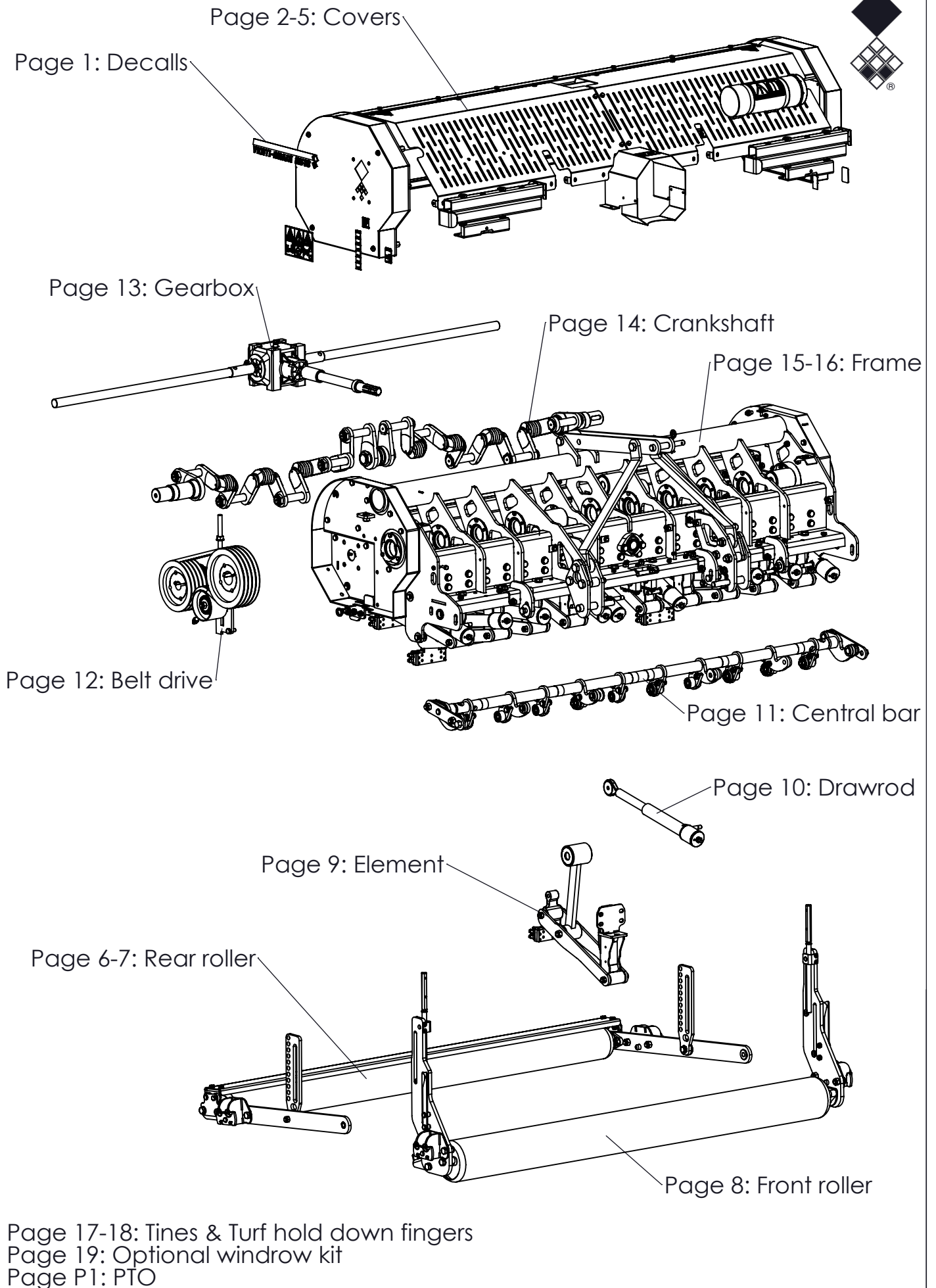

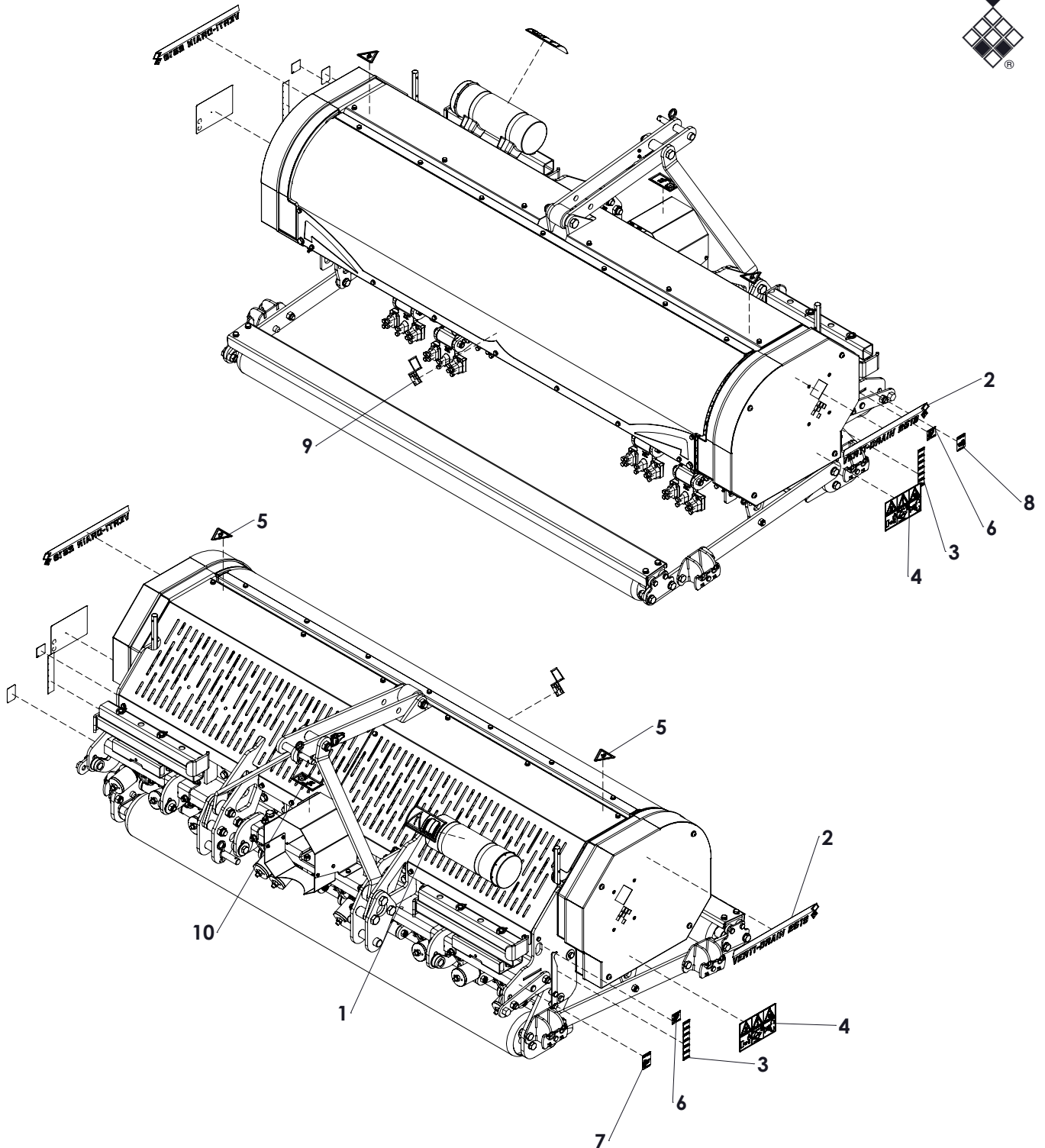

ITEM	PART NUMBER	DESCRIPTION	REMARKS	QUA
1	900.280.402	Safety decall manual		1
2	911.260.449	Label Verti-drain 2519		2
3	900.260.408	Heigth label 250		2
4	911.280.402	Safety Decall Verti-Drain		2
5	900.280.404	Decall cut off fingers		2
6	922.340.008	Decall fixation point		2
7	911.260.461	Angle decal left		1
8	911.260.460	Angle decal right		1
9	911.260.462	Logo Redexim		1
10	900.260.424	PTO Label 540 RPM		1

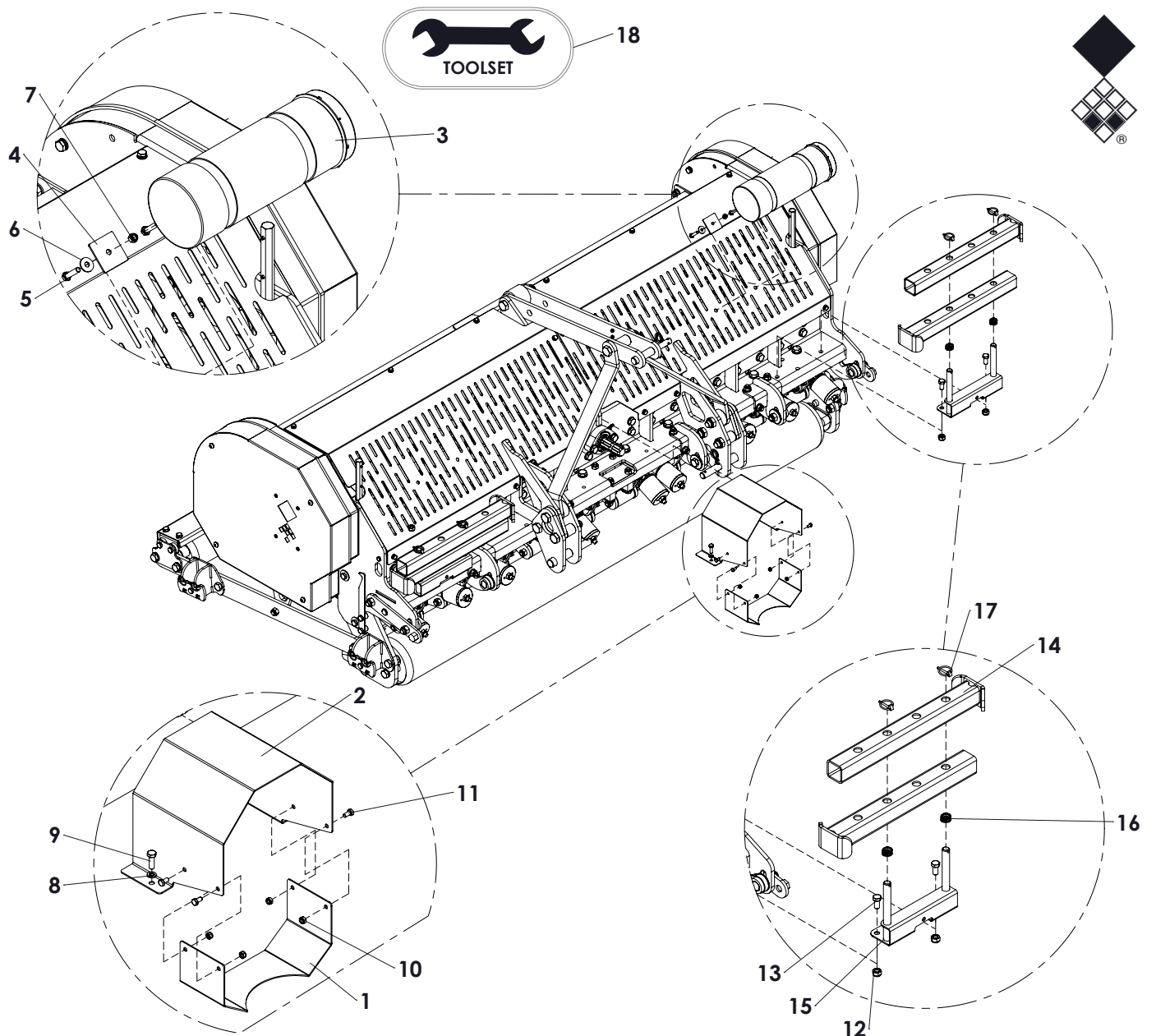

ITEM	PART NUMBER	DESCRIPTION	REMARKS	QUA
1	456.022.420	PTO cover lower side		1
2	456.022.460	PTO cover		1
3	444.803.100	Toolbox Complete		1
4	468.030.530	Toolbox contraplate		2
5	804.080.350	Bolt M8 x 35 - ISO 4017		2
6	864.080.024	Large washer M8 - DIN 9021		2
7	830.080.080	Self Lock Nut M8 - ISO 10511		2
8	866.080.020	Spring Washer M8 - DIN 127		2
9	804.080.250	Bolt M8 x 25 - ISO 4017		2
10	830.060.060	Self Lock Nut M6 - ISO 10511		4
11	804.060.120	Bolt M6 x 12 - ISO 4017		4
12	830.120.120	Self Lock Nut M12 - ISO 10511 Class 10.9		4
13	804.120.250	Bolt M12 x 25 - ISO 4017		4
14	462.504.780	Leg		4
15	470.034.002	Storage leg holder		2
16	576.020.190	Spring		2
17	523.040.320	Linch pin Ø4.5		2
18	468.083.060	Set of tools		1

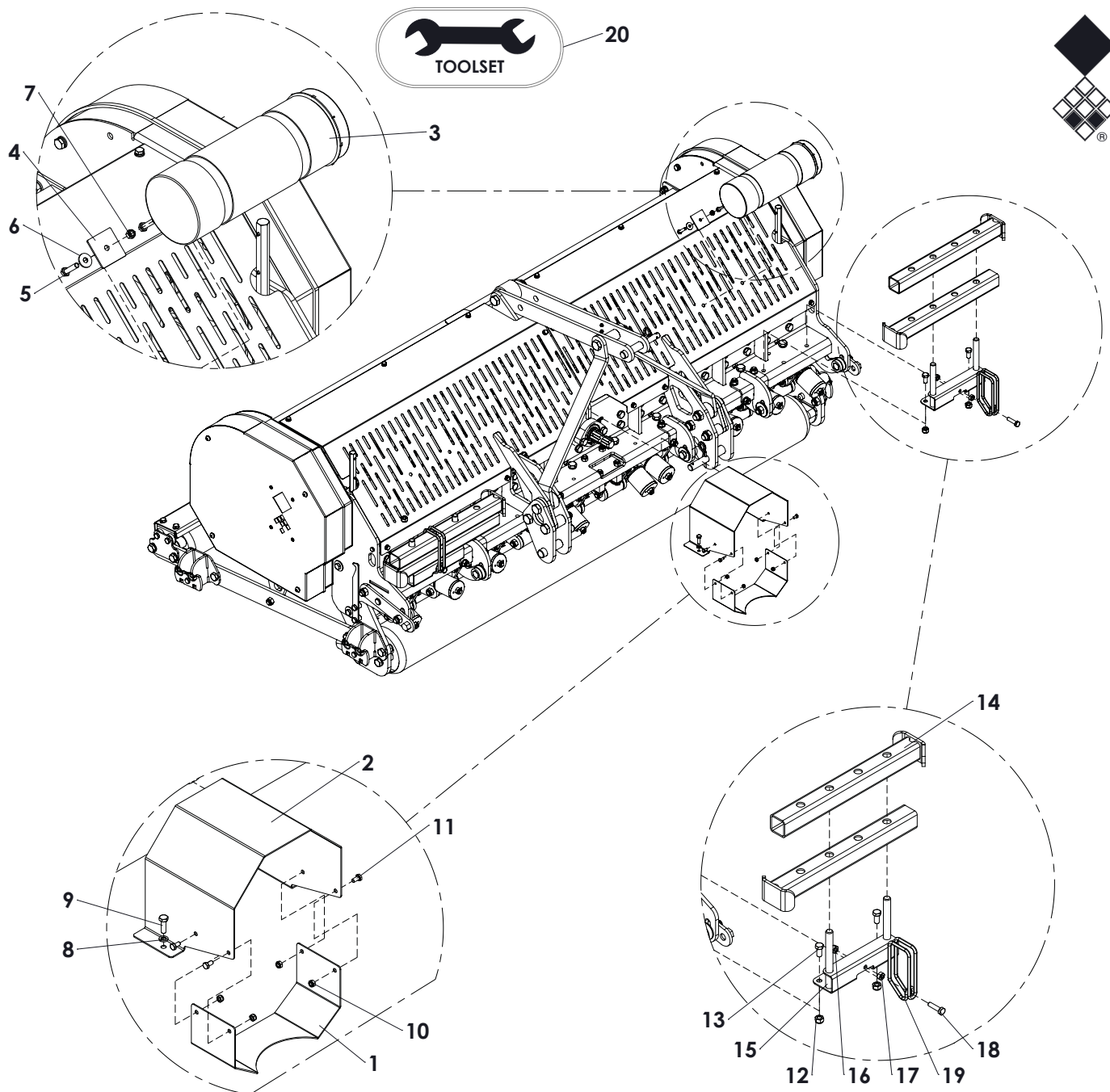

ITEM	PART NUMBER	DESCRIPTION	REMARKS	QUA
1	456.022.420	PTO cover lower side		1
2	456.022.460	PTO cover		1
3	444.803.100	Toolbox Complete		1
4	468.030.530	Toolbox contraplate		2
5	804.080.350	Bolt M8 x 35 - ISO 4017		2
6	864.080.024	Large washer M8 - DIN 9021		2
7	830.080.080	Self Lock Nut M8 - ISO 10511		2
8	866.080.020	Spring Washer M8 - DIN 127		2
9	804.080.250	Bolt M8 x 25 - ISO 4017		2
10	830.060.060	Self Lock Nut M6 - ISO 10511		4
11	804.060.120	Bolt M6 x 12 - ISO 4017		4
12	830.120.120	Self Lock Nut M12 - ISO 10511 Class 10.9		4
13	804.120.250	Bolt M12 x 25 - ISO 4017		4
14	462.504.780	Leg		4
15	470.034.002	Storage leg holder		2
16	830.100.100	Self Lock Nut M10 - ISO 10511		2
17	826.100.100	Nut M10 - DIN 934		2
18	804.100.400	Bolt M10 x 40 - ISO 4017		2
19	446.082.500	Rubber band 250x8		2
20	468.083.060	Set of tools		1

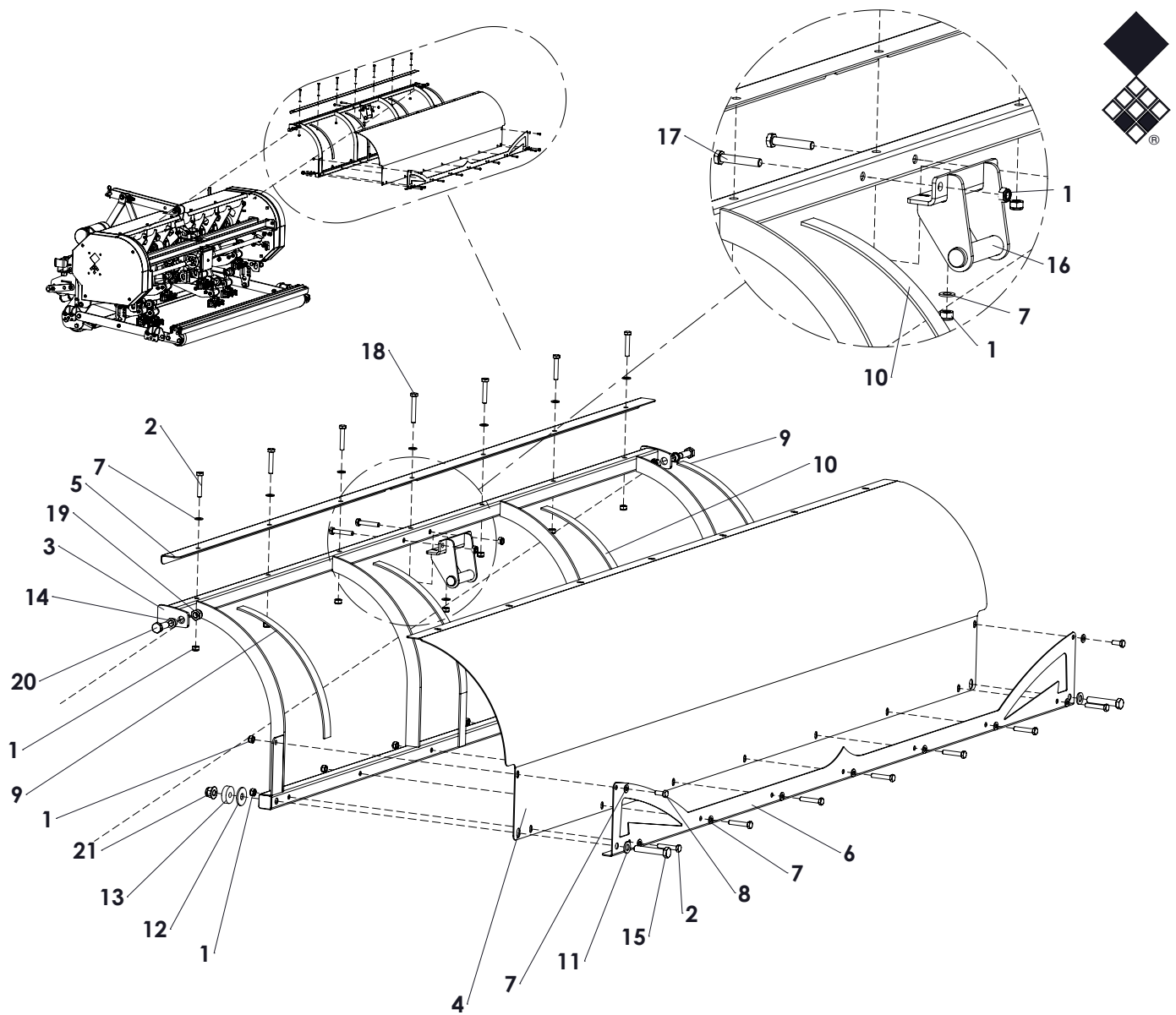

ITEM	PART NUMBER	DESCRIPTION	REMARKS	QUA
1	830.080.080	Self Lock Nut M8 - ISO 10511		18
2	802.080.450	Bolt M8 x 45 - ISO 4014		13
3	494.204.026	Rear cover frame		1
4	456.202.024	Cover		1
5	468.039.208	Clamp profile		1
6	468.039.201	Rear grill		1
7	864.080.030	Washer M8 - ISO 7089		18
8	804.080.200	Bolt M8 x 20 - ISO 4017		2
9	446.033.500	Isolator rubber		2
10	446.034.600	Isolator rubber		2
11	864.120.030	Washer M12 - ISO 7089		2
12	864.120.031	Large washer M12 - DIN 9021		2
13	446.100.100	Rubber ring		2
14	404.120.130	Distance bush tine holder		2
15	802.120.700	Bolt M12 x 70 - ISO 4014		2
16	470.041.302	Support bracket		1
17	802.080.450	Bolt M8 x 45 - ISO 4014		2
18	802.080.550	Bolt M8 x 55 - ISO 4014		1
19	830.120.120	Self Lock Nut M12 - ISO 10511 Class 10		2
20	804.120.350	Bolt M12 x 35 - ISO 4017		2
21	830.120.125	Self lock nut M12 - ISO 7043		2
	465.202.026	Rear cover complete	Contains items 1-10	

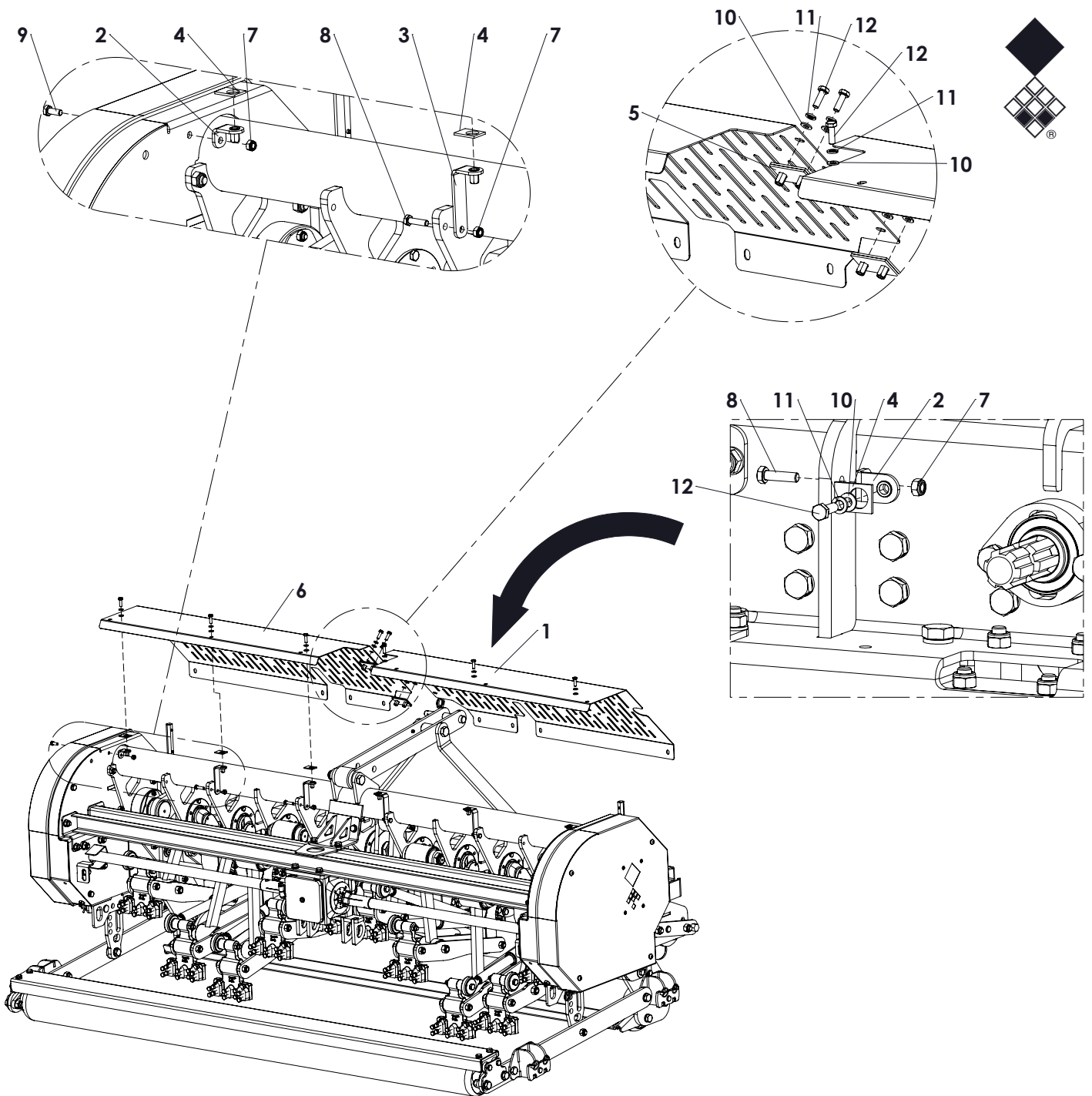

From Serial no H2192203

ITEM	PART NUMBER	DESCRIPTION	REMARKS	QUA
1	456.101.054	Front cover right		1
2	464.040.430	Bracket		10
3	466.041.010	Bracket M8 WL=85		4
4	446.030.350	Cover rubber		14
5	466.030.602	Cover support		2
6	456.101.056	Front cover left		1
7	830.080.080	Self Lock Nut M8 - ISO 10511		14
8	804.080.300	Bolt M8 x 30 - ISO 4017		12
9	804.080.200	Bolt M8 x 20 - ISO 4017		2
10	864.080.030	Washer M8 - ISO 7089		18
11	866.080.020	Spring Washer M8 - DIN 127		18
12	804.080.250	Bolt M8 x 25 - ISO 4017		18

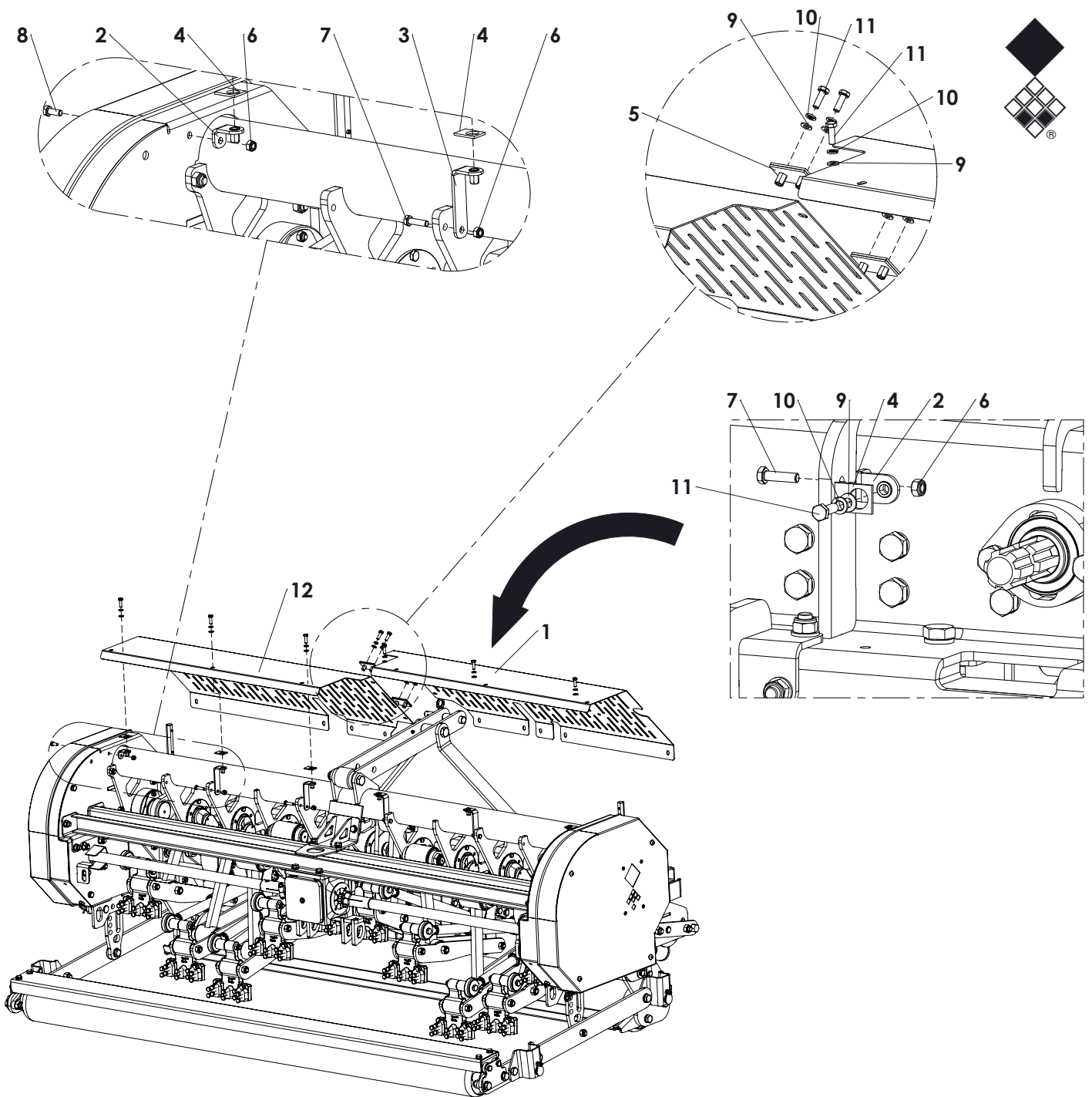

Till Serial no H2192202

ITEM	PART NUMBER	DESCRIPTION	REMARKS	QUA
1	456.101.048	Front cover right		1
2	464.040.430	Bracket		12
3	466.041.010	Bracket M8 WL=85		4
4	446.030.350	Cover rubber		16
5	466.030.602	Cover support		2
6	830.080.080	Self Lock Nut M8 - ISO 10511		16
7	804.080.300	Bolt M8 x 30 - ISO 4017		12
8	804.080.200	Bolt M8 x 20 - ISO 4017		2
9	864.080.030	Washer M8 - ISO 7089		20
10	866.080.020	Spring Washer M8 - DIN 127		20
11	804.080.250	Bolt M8 x 25 - ISO 4017		20
12	456.101.053	Front cover left		1

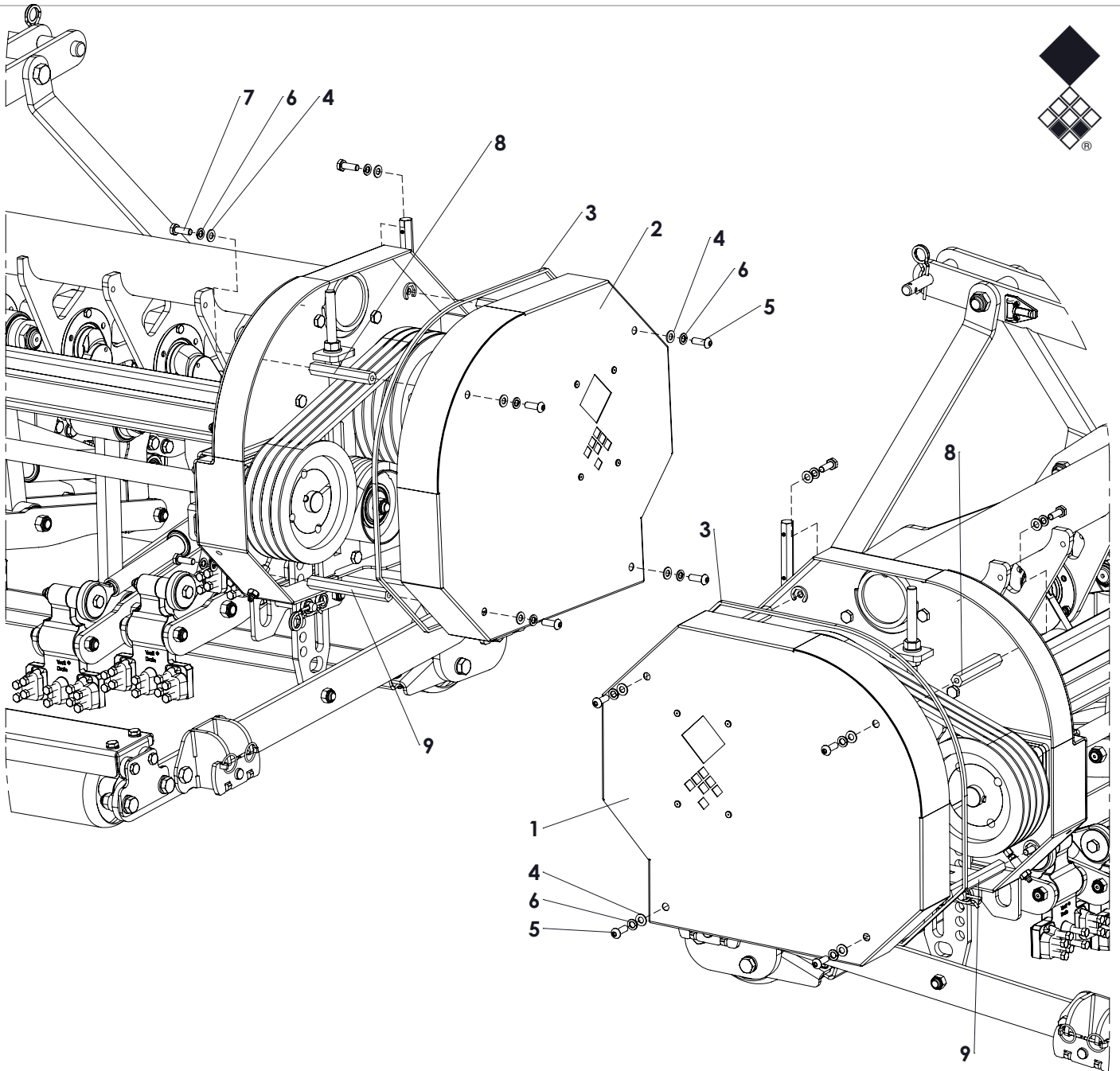

ITEM	PART NUMBER	DESCRIPTION	REMARKS	QUA
1	456.063.008	Left cover		1
2	456.063.009	Right cover		1
3	446.069.204	Rubber U-seal L=1990		2
4	864.100.030	Washer M10 - ISO 7089		16
5	815.100.300	Bolt M10 x 30 - ISO 7380		8
6	866.100.020	Spring Washer M10 - DIN 127		16
7	804.100.300	Bolt M10 x 30 - ISO 4017		8
8	472.191.200	Stud hex.19 L=125		6
9	472.191.600	Stud hex.19 L=165		2

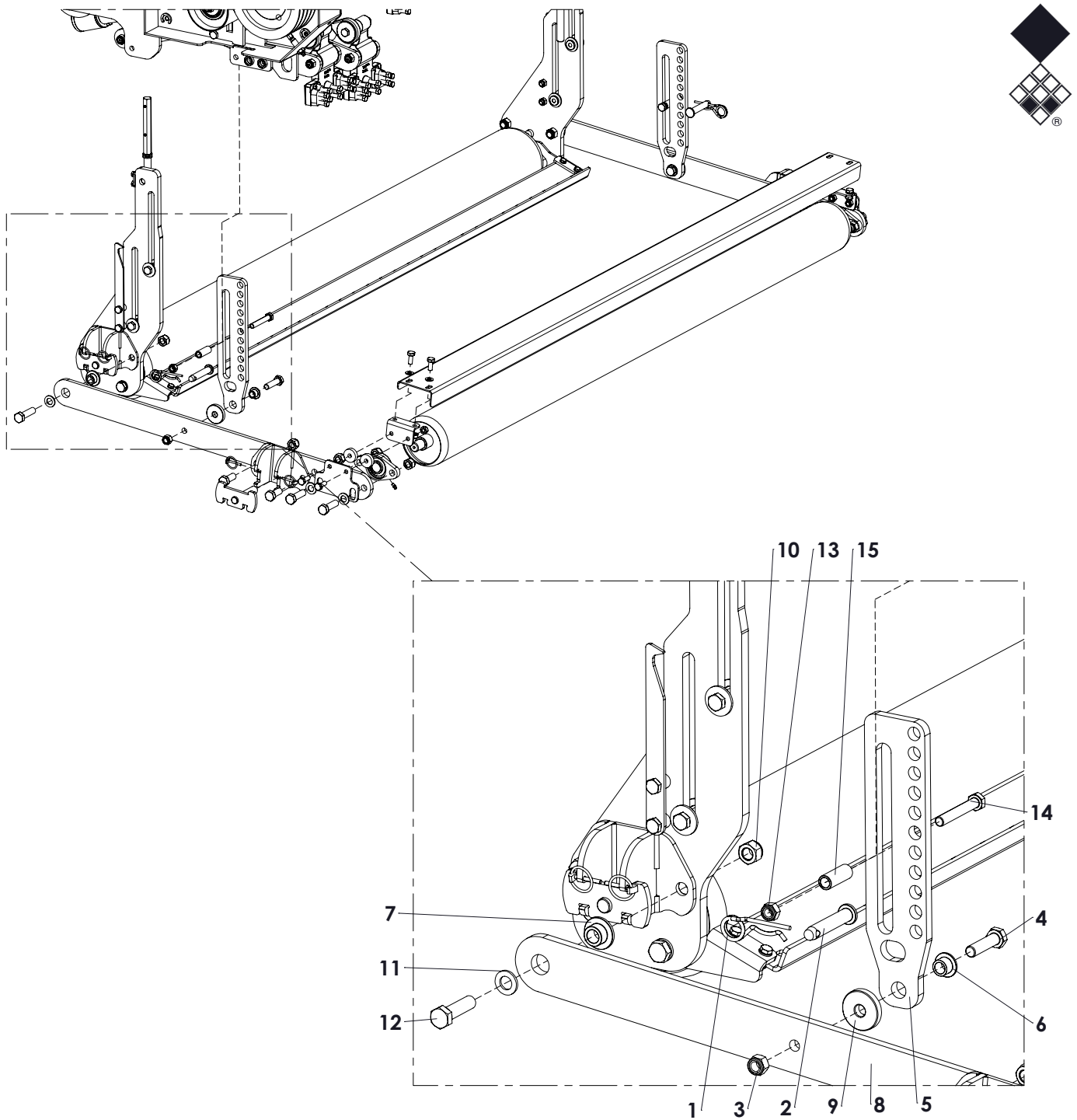

ITEM	PART NUMBER	DESCRIPTION	REMARKS	QUA
1	523.051.000	R-clip Round 5, DIN 11024		2
2	424.160.890	Pin		2
3	830.140.140	Self Lock Nut M14 10.9 - ISO 10511		2
4	802.140.550	Bolt M14 x 55 - ISO 4014 - 10.9		2
5	468.123.650	Rear roller guide plate		2
6	404.140.150	Distance bush		2
7	404.160.165	Distance bush		2
8	464.129.500	Rear roller support		2
9	412.140.100	Distance washer		2
10	830.160.160	Self Lock Nut M16 10.9 - ISO 10511		4
11	864.160.030	Washer M16 - ISO 7089		2
12	802.160.600	Bolt M16 x 60 - ISO 4014 - 10.9		2
13	830.120.120	Self Lock Nut M12 - ISO 10511 Class 10.9		2
14	802.120.800	Bolt M12 x 80 - ISO 4014		2
15	406.130.480	Distance bush Ø13/Ø18 L=48		2

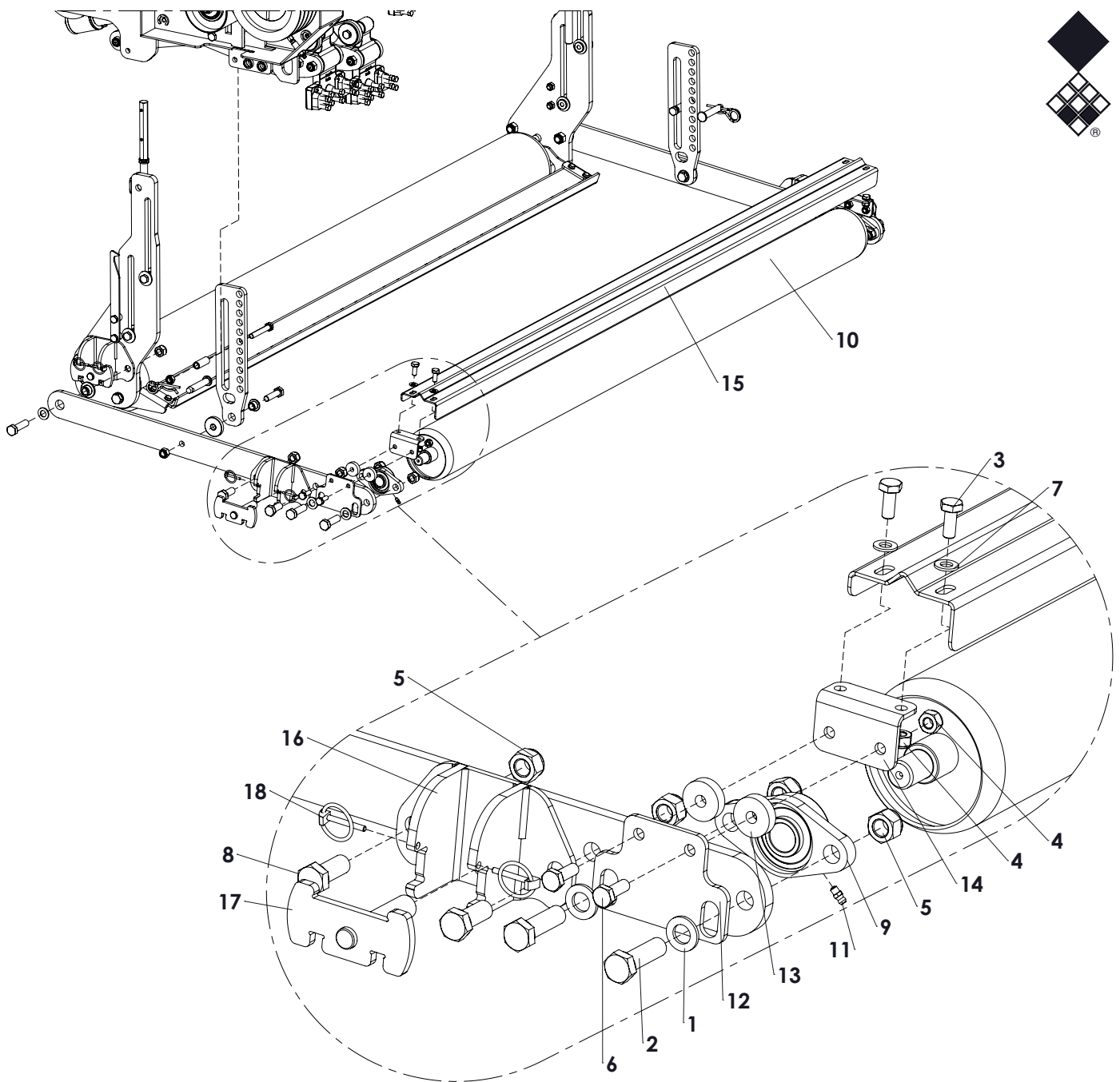

ITEM	PART NUMBER	DESCRIPTION	REMARKS	QUA
1	864.160.030	Washer M16 - ISO 7089		4
2	802.160.550	Bolt M16 x 55		4
3	804.100.250	Bolt M10 x 25 - ISO 4017		4
4	830.100.100	Self Lock Nut M10 - ISO 10511		8
5	830.160.160	Self Lock Nut M16-ISO 10511 Class 10		8
6	804.100.300	Bolt M10 x 30 - ISO 4017		4
7	864.100.030	Washer M10 - ISO 7089		4
8	804.160.400	Bolt M16 x 40 - ISO 4017		4
9	742.250.360	Bearing UCFL 205		2
10	488.133.204	Rear roller		1
11	880.060.100	Grease nipple M6 DIN 71412A		2
12	468.051.304	Scraper plate		2
13	446.100.100	Rubber ring		4
14	468.040.502	Scraper support		2
15	468.029.205	Rear scraper		1
16	470.061.722	Bracket stand leg		2
17	470.081.206	Lock pin		2
18	523.040.320	Linch pin Ø4.5		2

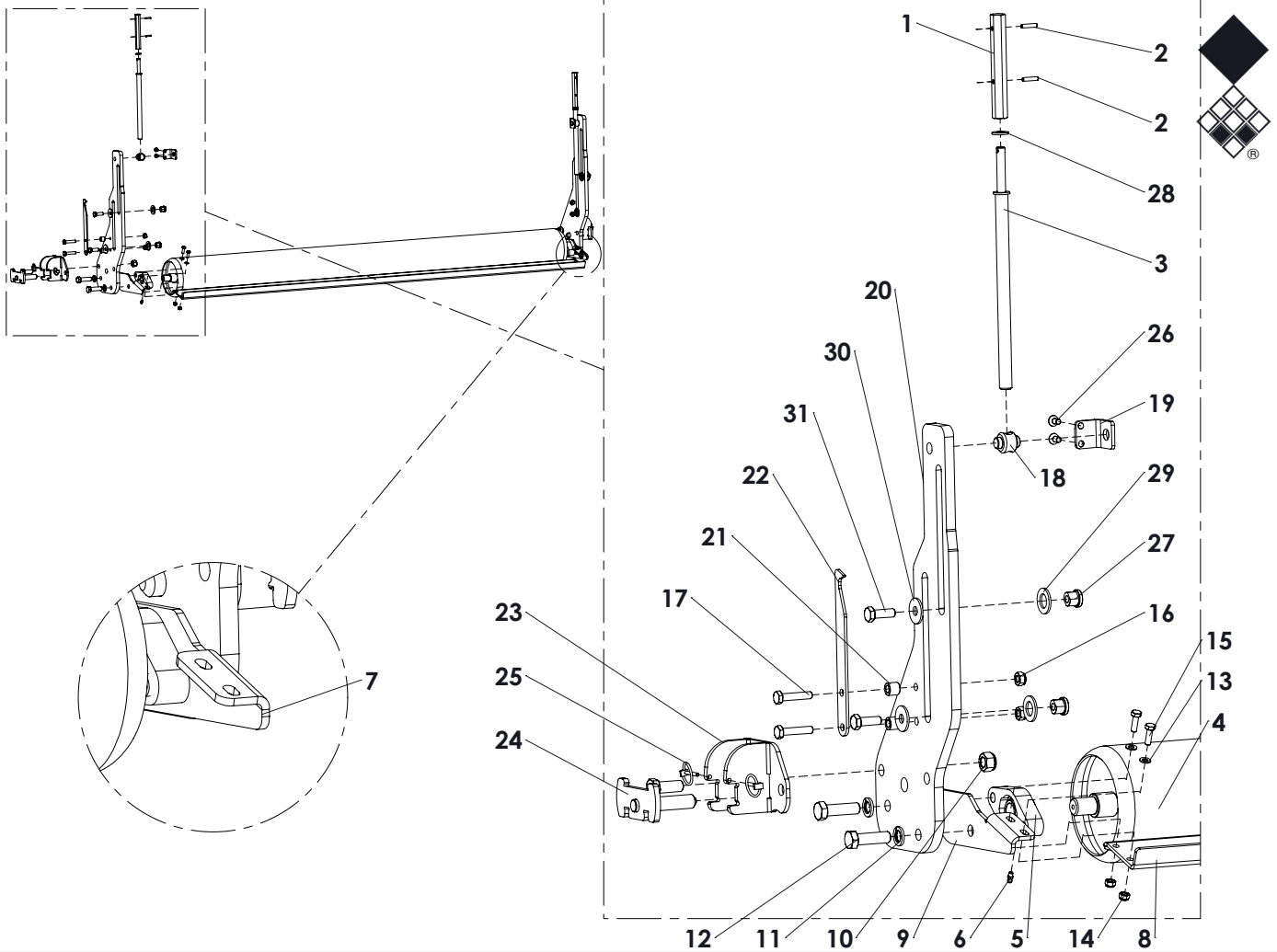

ITEM	PART NUMBER	DESCRIPTION	REMARKS	QUA
1	422.191.200	Spindle head		2
2	878.050.240	Roll pin 5x24 - ISO 8752		4
3	426.184.000	Spindle		2
4	488.168.197	Front roller		1
5	744.250.660	Bearing complete		2
6	880.060.100	Grease nipple M6 DIN 71412A		2
7	468.062.430	Scraper support right		1
8	468.059.195	Scraper and turf hold down beam		1
9	468.062.432	Scraper support left		1
10	830.160.160	Self Lock Nut M16 10.9 - ISO 10511		2
11	866.160.020	Spring Washer M16 - DIN 127		4
12	804.160.550	Bolt M16 x 55 - ISO 4017		4
13	864.080.030	Washer M8 - ISO 7089		4
14	830.080.080	Self Lock Nut M8 - ISO 10511		4
15	804.080.250	Bolt M8 x 25 - ISO 4017		4
16	830.100.100	Self Lock Nut M10 - ISO 10511		4
17	802.100.500	Bolt M10 x 50 - ISO 4014		4
18	426.300.400	Spindle nut		2
19	468.050.440	Spindle nut bracket		2
20	468.156.250	Front roller support		2
21	406.180.170	Distance bush Ø18/Ø10.2 L=16.5		4
22	468.042.400	Height indicator		2
23	470.061.722	Bracket stand leg		2
24	470.081.206	Lock pin		2
25	523.040.320	Linch pin Ø4.5		4
26	816.080.160	Bolt M8 x 16 - DIN 7991		4
27	410.250.210	Sleeve bearing bush		4
28	864.120.030	Washer M12 - ISO 7089		2
29	864.200.030	Washer M20 - ISO 7089		4
30	864.120.031	Large washer M12 - DIN 9021		4
31	804.120.350	Bolt M12 x 35 - ISO 4017		4

Check element strip, else see page 09

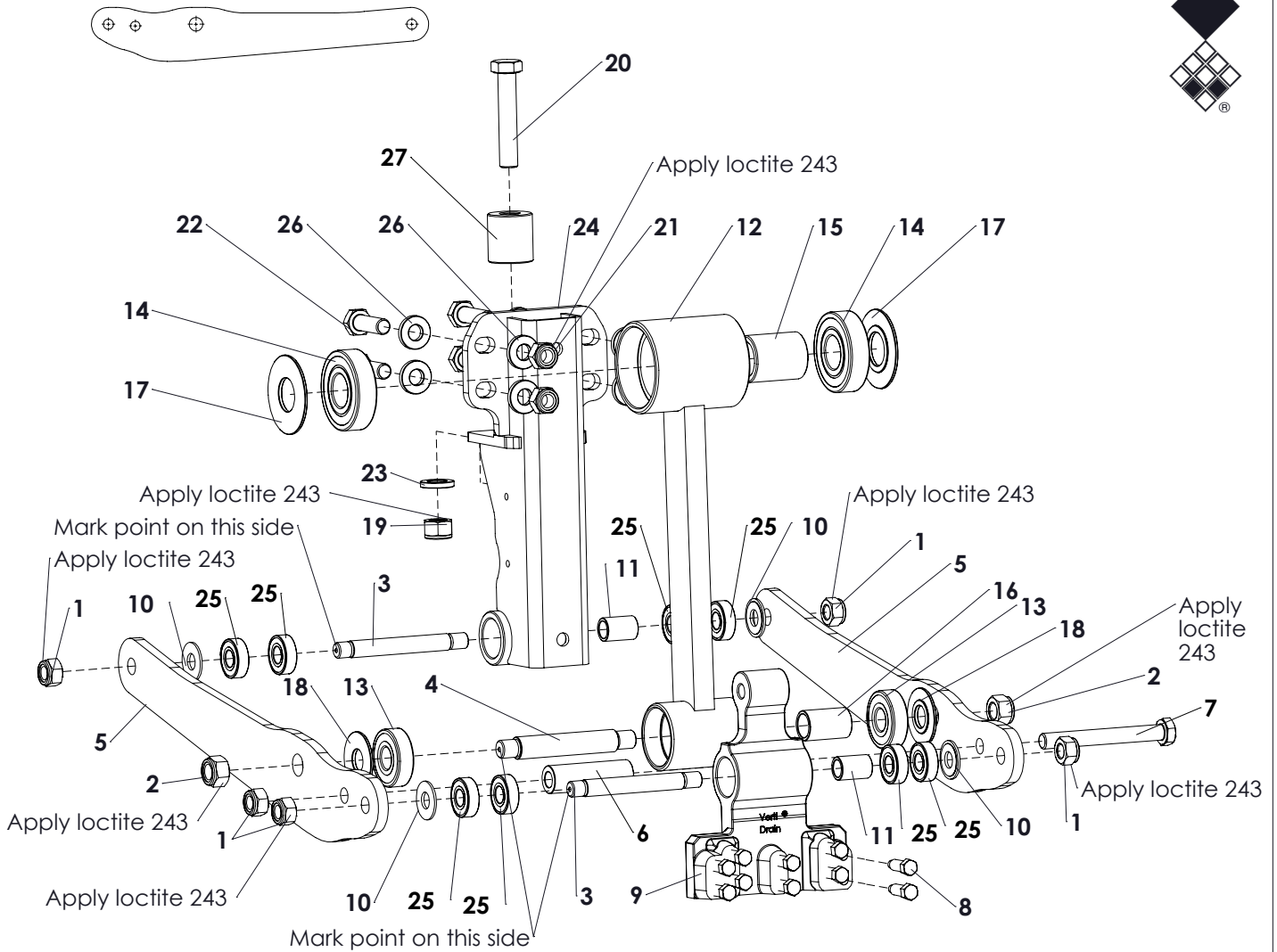

ITEM	PART NUMBER	DESCRIPTION	REMARKS	QUA
1	830.140.140	Self Lock Nut M14-ISO 10511 Class 10		5
2	830.160.160	Self Lock Nut M16-ISO 10511 Class 10		2
3	2490415	Support axis		2
4	416.201.340	Support axis		1
5	468.105.320	Element strip		2
6	402.140.790	Bush Ø25/Ø14 L=79.5		1
7	802.141.202	Bolt M14 x 120 - ISO 4014 Class 10.9		1
8	4001675	Tineholder bolt M10x30		10
9	448.154.201	Tine Holder		1
10	412.150.050	Distance washer		2
11	2601530	Inner bush		1
12	468.204.000	Connecting rod		1
13	713.200.150	Bearing 6304-LLU		2
14	713.300.190	Bearing 6306-2RS		2
15	402.300.280	Inner bush big end		1
16	402.210.160	Inner bush		1
17	412.300.040	Distance washer		2
18	412.200.040	Distance washer		2
19	830.160.160	Self Lock Nut M16-ISO 10511 Class 10		1
20	802.160.850	Bolt M16 x 85 - Class 10.9 ISO 4014		1
21	830.140.140	Self Lock Nut M14-ISO 10511 Class 10		4
22	804.140.452	Bolt M14 x 45 10.9 - ISO 4017		4
23	406.170.054	Washer Ø17/Ø30 L=5		10
24	494.031.013	Bracket		1
25	713.150.110	Bearing 6202-2RSH		8
26	412.050.300	Washer		8
27	406.170.430	Distance bush Ø17/Ø40 L=43		1

Check element strip, else see page 09

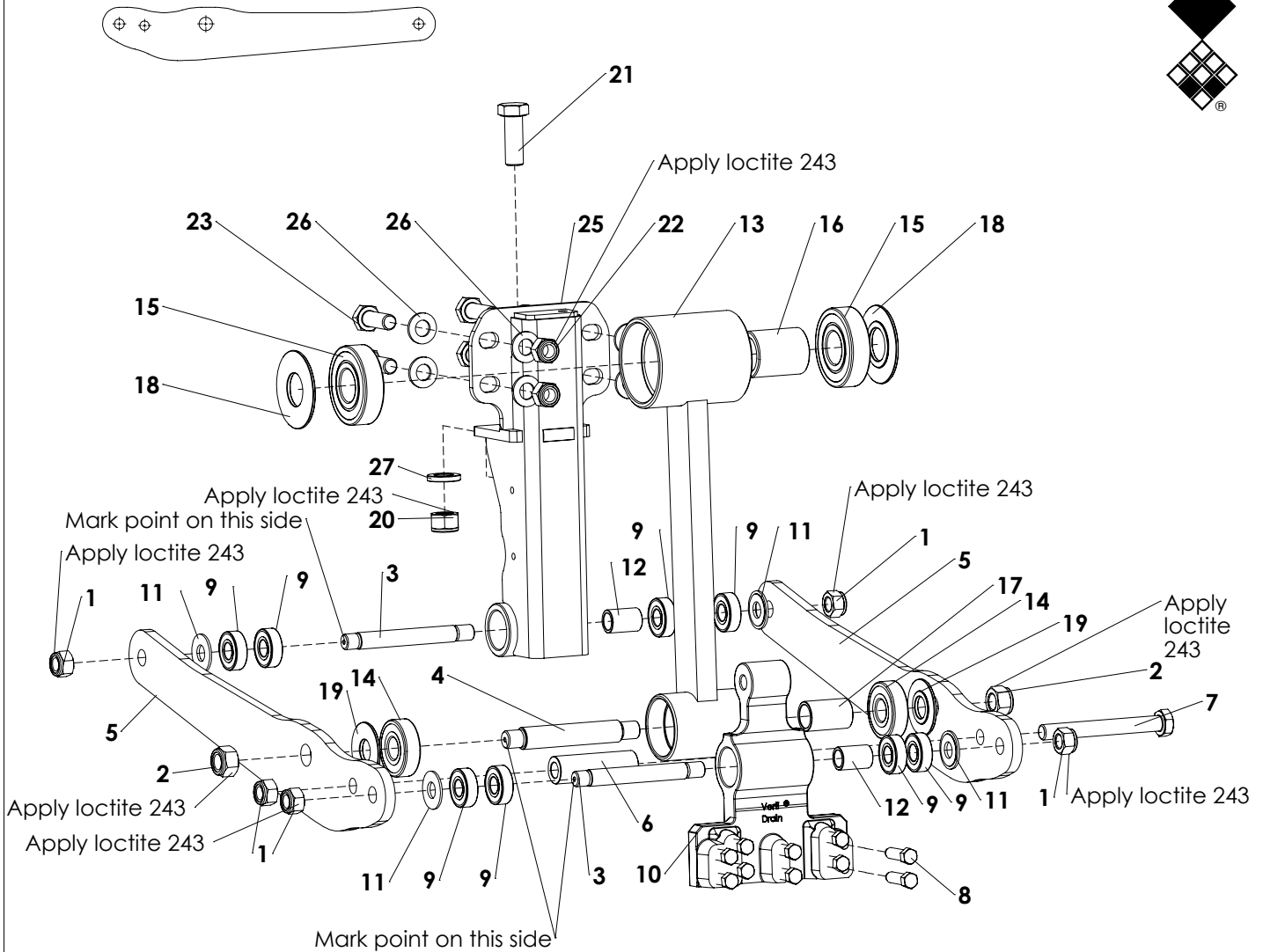

ITEM	PART NUMBER	DESCRIPTION	REMARKS	QUA
1	830.140.140	Self Lock Nut M14-ISO 10511 Class 10		5
2	830.160.160	Self Lock Nut M16-ISO 10511 Class 10		2
3	2490415	Support axis		2
4	416.201.340	Support axis		1
5	468.105.320	Element strip		2
6	402.140.790	Bush Ø25/Ø14 L=79.5		1
7	802.141.202	Bolt M14 x 120 - ISO 4014 Class 10.9		1
8	4001675	Tine holder bolt M10x35		10
9	713.150.110	Bearing 6202-LLU		8
10	448.154.201	Tine Holder		1
11	412.150.050	Distance washer		4
12	2601530	Inner bush		2
13	468.204.000	Connecting rod		1
14	713.200.150	Bearing 6304-LLU		2
15	713.300.190	Bearing 6306-2RS		2
16	402.300.280	Inner bush big end		1
17	402.210.160	Inner bush		1
18	412.300.040	Distance washer		2
19	412.200.040	Distance washer		2
20	830.160.160	Self Lock Nut M16-ISO 10511 Class 10		1
21	804.160.450	Bolt M16 x 45 - ISO 4017		1
22	830.140.140	Self Lock Nut M14-ISO 10511 Class 10		4
23	804.140.402	Bolt M14 x 40 - ISO 4017 Class 10.9		4
24	864.160.030	Washer M16 - ISO 7089		2
25	494.031.013	Bracket		1
26	864.140.030	Washer M14 - ISO 7089		8
27	406.170.054	Washer Ø17/Ø30 L=5		10

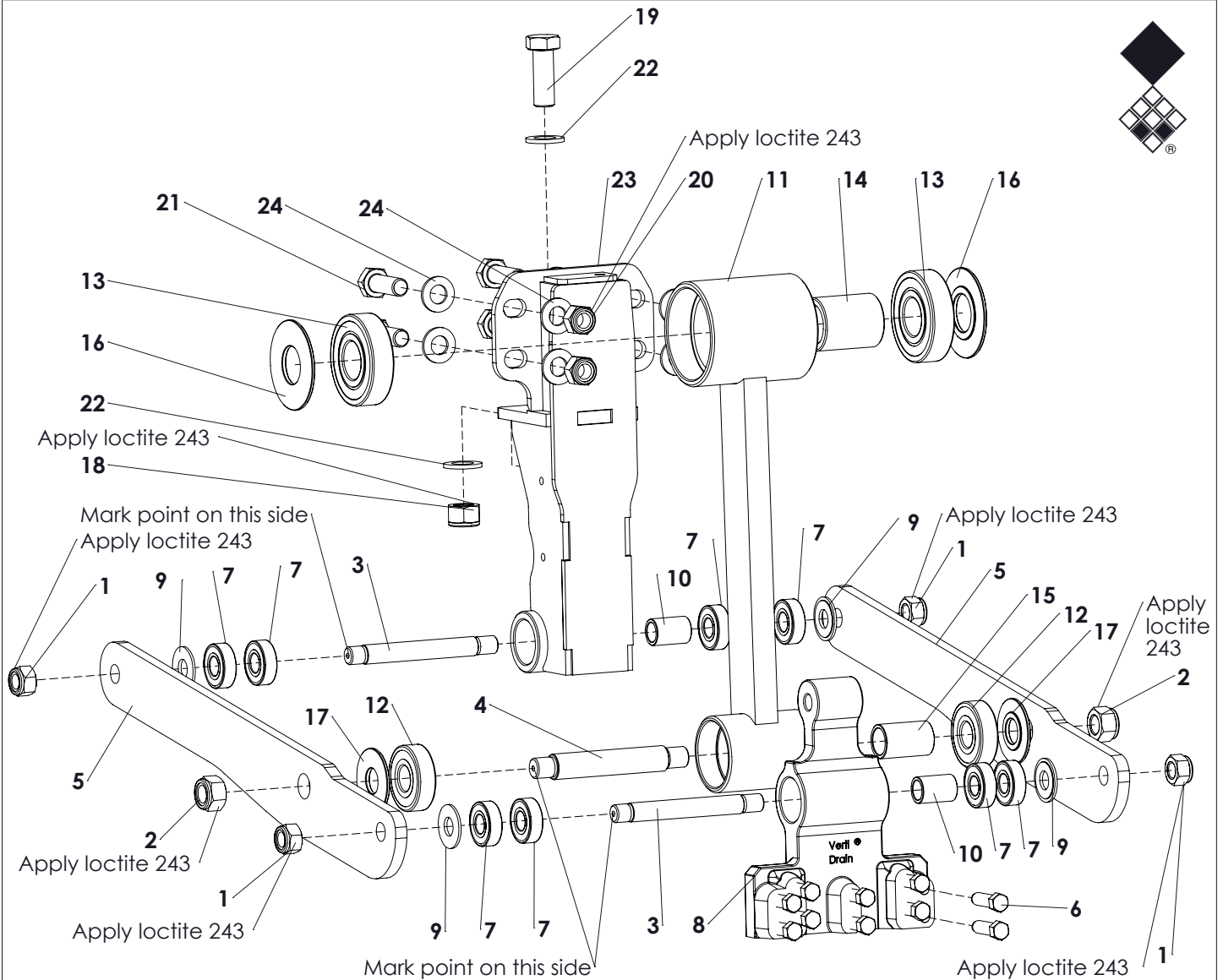

ITEM	PART NUMBER	DESCRIPTION	REMARKS	QUA
1	830.140.140	Self Lock Nut M14 10.9 - ISO 10511		4
2	830.160.160	Self Lock Nut M16 10.9 - ISO 10511		2
3	2490415	Support axis		2
4	416.201.340	Support axis		1
5	468.105.001	Element strip		2
6	4001675	Tine holder bolt M10x35		10
7	713.150.110	Bearing 6202-LLU		8
8	448.154.201	Tine Holder		1
9	412.150.050	Distance washer		4
10	2601530	Inner bush		2
11	468.204.000	Connecting rod		1
12	713.200.150	Bearing 6304-LLU		2
13	713.300.190	Bearing 6306-2RS		2
14	402.300.280	Inner bush big end		1
15	402.210.160	Inner bush		1
16	412.300.040	Distance washer		2
17	412.200.040	Distance washer		2
18	830.160.160	Self Lock Nut M16 10.9 - ISO 10511		1
19	804.160.452	Bolt M16 x 45 - ISO 4017 Class 10.9		1
20	830.140.140	Self Lock Nut M14 10.9 - ISO 10511		4
21	804.140.402	Bolt M14 x 40 - ISO 4017 Class 10.9		4
22	864.160.030	Washer M16 - ISO 7089		2
23	494.031.013	Bracket		1
24	864.140.030	Washer M14 - ISO 7089		8

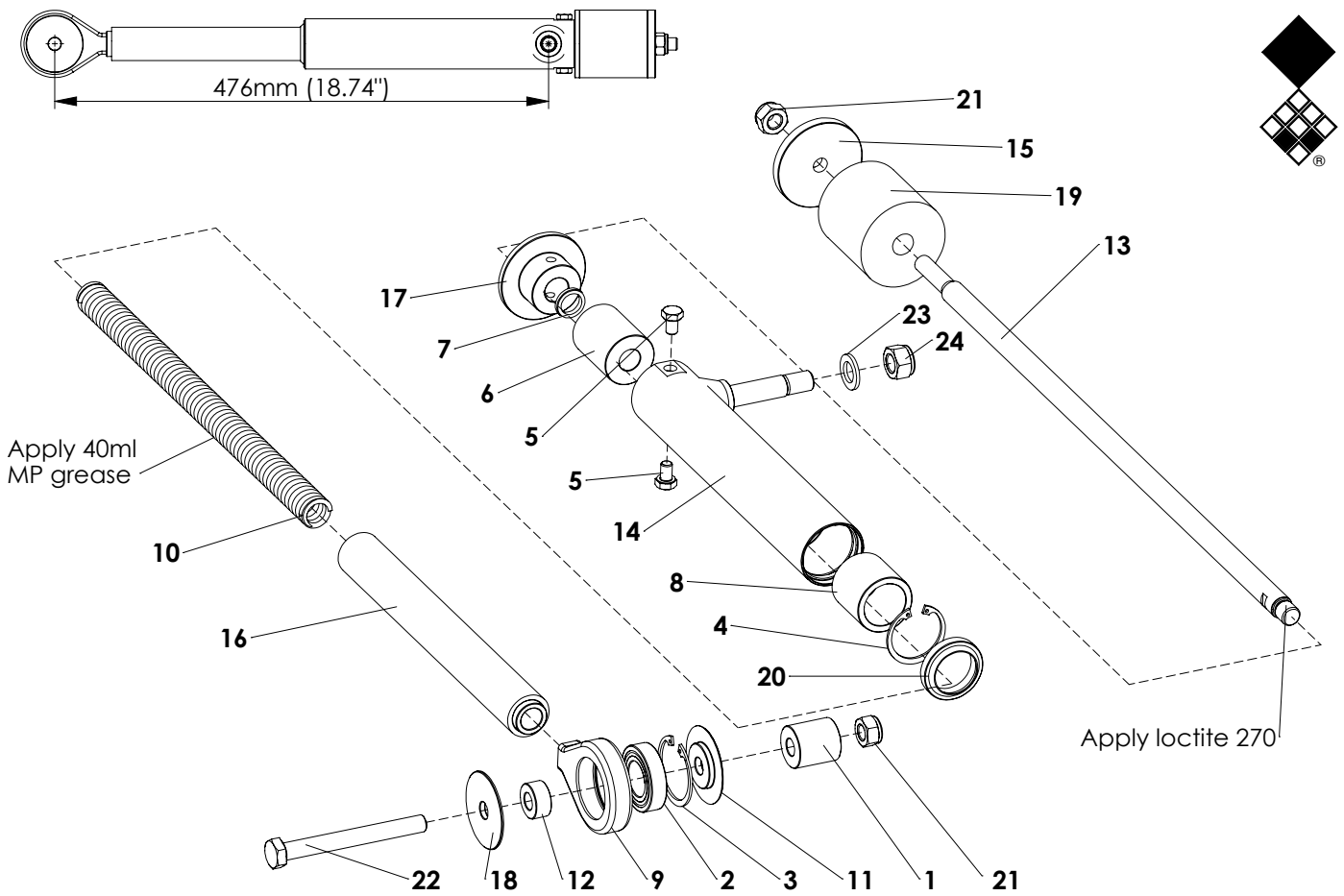

Placement of draw rods on machine

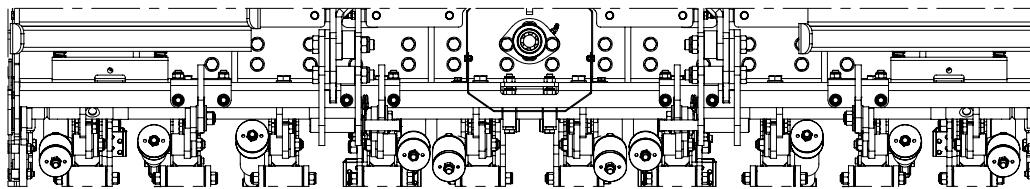

ITEM	PART NUMBER	DESCRIPTION	REMARKS	QUA
1	402.120.320	Bush	Check height 32mm(1.26")	1
	402.120.270	Bush	Check height 27mm(1.05")	1
2	713.250.120	Bearing 6005-LLU		1
3	872.047.180	Circlip DIN 472 - 47 x 1.75		1
4	872.042.182	Circlip D=42 - DIN 472		1
5	804.080.120	Bolt M8 x 12 - ISO 4017		2
6	444.320.600	Bearing bush		1
7	761.160.030	Seal		1
8	444.320.400	Bearing bush		1
9	448.640.820	Draw rod head with hole		1
10	576.235.100	Compression spring		1
11	404.120.050	Dust washer Ø55/Ø32/Ø12 L=5.2		1
12	406.120.120	Distance bush Ø25/Ø12 L=12		1
13	414.165.600	Draw rod		1
14	478.482.600	Slide guide		1
15	408.120.100	Ring		1
16	478.322.650	Slide cover		1
17	472.500.140	Cover with thread		1
18	404.120.040	Dust washer Ø55/Ø32/Ø12 L=4.25		1
19	446.500.502	Rubber stop		1
20	761.320.100	Wiper ASM 32x45x7/10		1
21	831.120.120	Self Lock Nut M12x1.25 - ISO 10511 10.9		2
22	806.121.100	Bolt M12x1.25x110 - DIN 960 - 10.9		1
23	864.140.032	Special Washer M14		1
24	830.140.140	Self Lock Nut M14-ISO 10511 Class 10		1
	490.485.000	Draw rod complete	Contains items 2-20	10

Till serial no H2192202

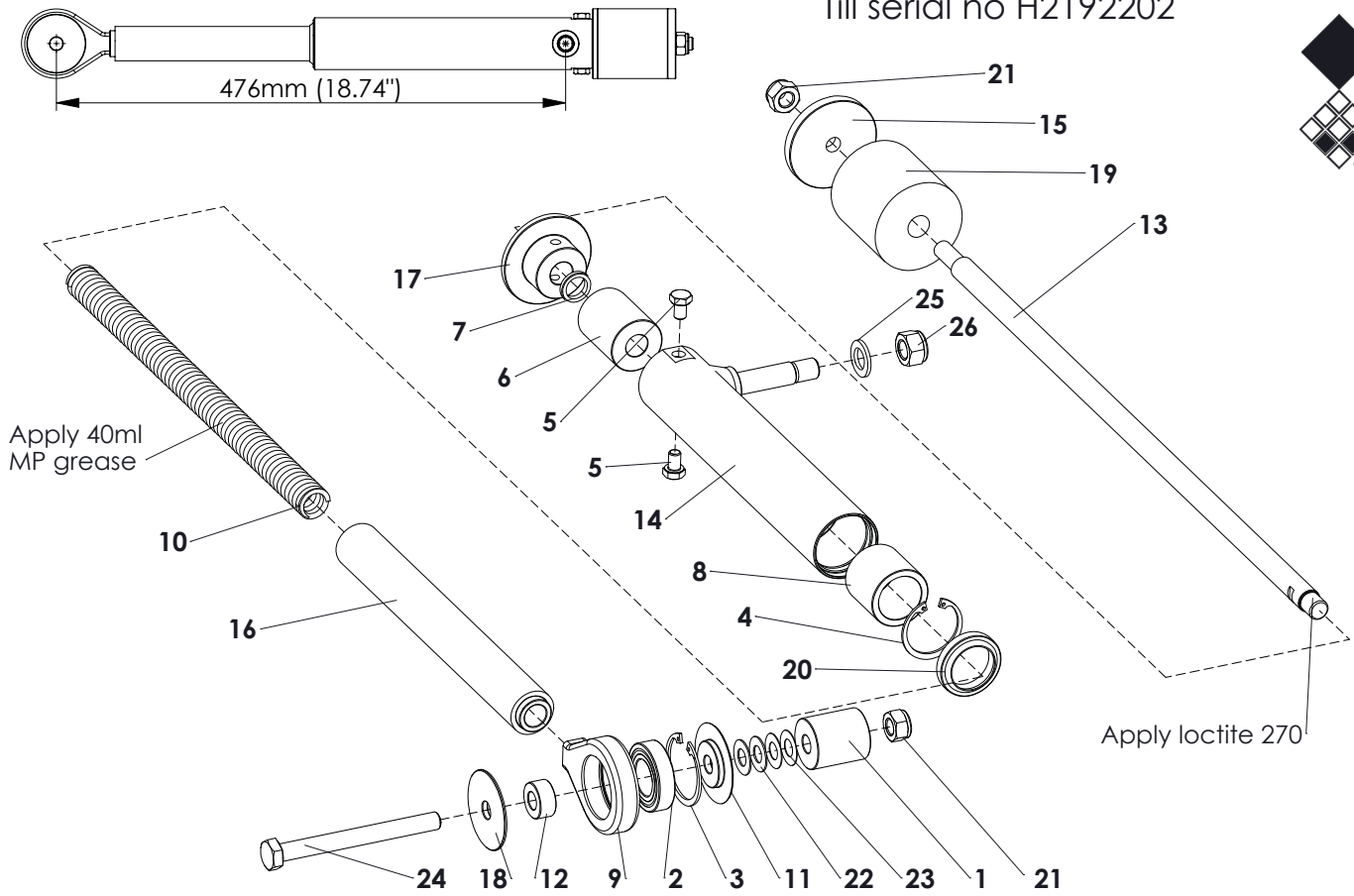

Placement of draw rods on machine

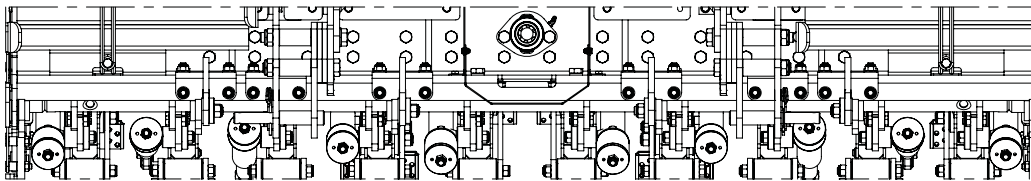

ITEM	PART NUMBER	DESCRIPTION	REMARKS	QUA
1	402.120.390	Bush		1
2	713.250.120	Bearing 6005-LLU		1
3	872.047.180	Circlip DIN 472 - 47 x 1.75		1
4	872.042.182	Circlip D=42 - DIN 472		1
5	804.080.120	Bolt M8 x 12 - ISO 4017		2
6	444.320.600	Bearing bush		1
7	761.160.030	Seal		1
8	444.320.400	Bearing bush		1
9	448.640.820	Draw rod head with hole		1
10	576.235.100	Compression spring		1
11	404.120.050	Dust washer Ø55/Ø32/Ø12 L=5.2		1
12	406.120.120	Distance bush Ø25/Ø12 L=12		1
13	414.165.600	Draw rod		1
14	478.482.600	Slide guide		1
15	408.120.100	Ring		1
16	478.322.650	Slide cover		1
17	472.500.140	Cover with thread		1
18	404.120.040	Dust washer Ø55/Ø32/Ø12 L=4.25		1
19	446.500.502	Rubber stop		1
20	761.320.100	Wiper ASM 32x45x7/10		1
21	831.120.120	Self Lock Nut M12x1.25 - ISO 10511 10.9		1
22	869.012.100	Shims 24x12x1		2
23	869.012.050	Shims 24x12x0.5		2
24	806.121.200	Bolt M12x1.25x120 - DIN 960 - 10.9		1
25	864.140.032	Special Washer M14		1
26	830.140.140	Self Lock Nut M14 - ISO 10511		1
	490.485.000	Draw rod complete	Contains items 2-20	

From serial no H2192203

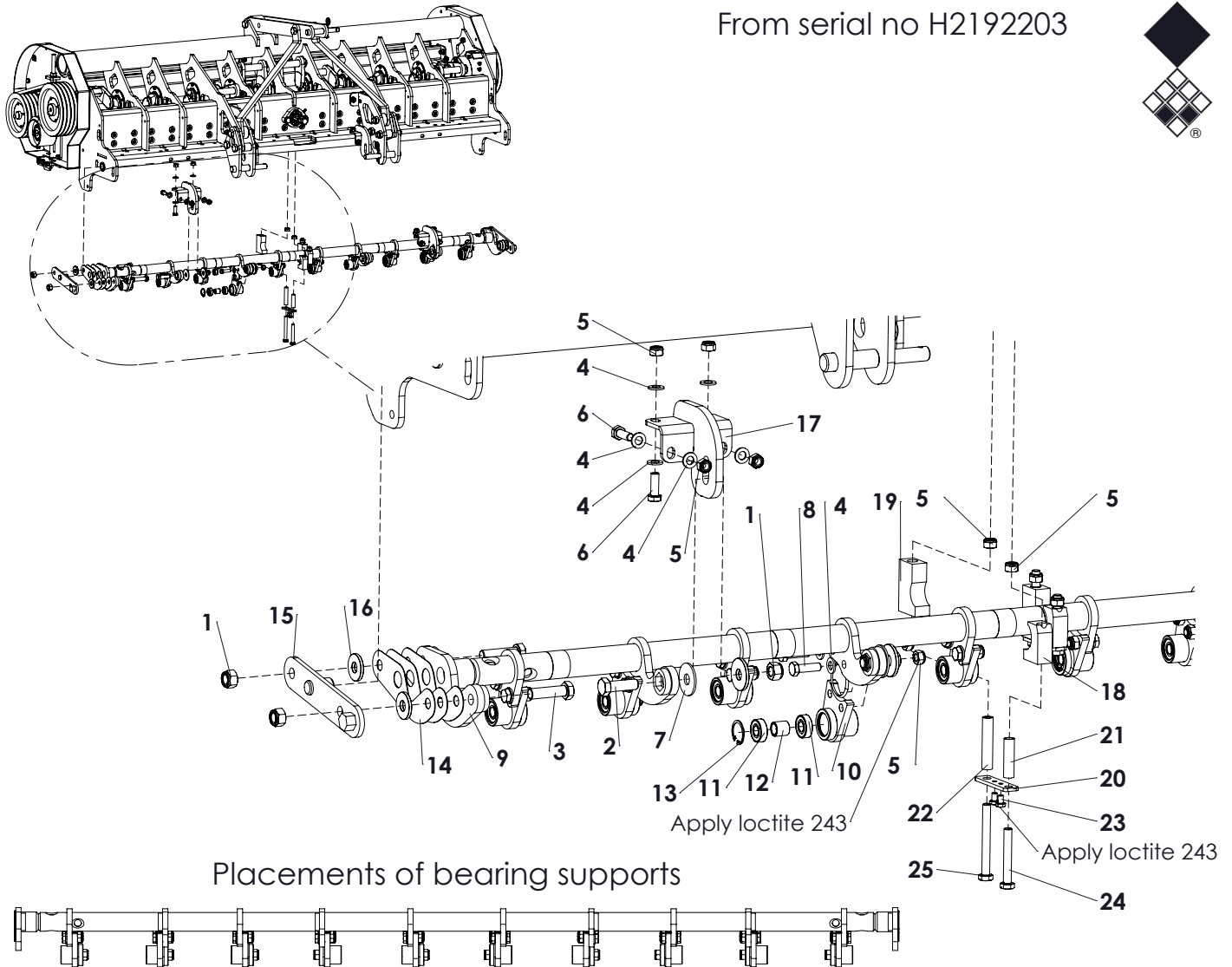

Placements of bearing supports

ITEM	PART NUMBER	DESCRIPTION	REMARKS	QUA
1	830.160.160	Self Lock Nut M16 10.9 - ISO 10511		6
2	804.160.500	Bolt M16 x 50 - ISO 4017		2
3	802.160.600	Bolt M16 x 60 - ISO 4014 - 10.9		4
4	864.120.030	Washer M12 - ISO 7089		40
5	830.120.120	Self Lock Nut M12 - ISO 10511 Class 10.9		28
6	804.120.350	Bolt M12 x 35 - ISO 4017		8
7	864.160.031	Large washer M16 - DIN 9021		4
8	804.120.402	Bolt M12 x 40 - ISO 4017 Class 10.9		20
9	478.151.924	Central bar		1
10	470.120.500	Bearing support		1
11	713.150.110	Bearing 6202-LLU		20
12	406.160.222	Bush		10
13	872.035.150	Circlip D=35 - DIN 472		10
14	468.012.052	Spacer	Thickness 1mm (0.039")	6
	468.032.052	Spacer	Thickness 2.5mm (0.098")	2
15	466.080.275	Handle		2
16	402.160.050	Distance bush Ø42/Ø16 L=5		4
17	470.121.400	Central bar support		2
18	444.250.602	Clamp block small		2
19	444.250.802	Clamp block large		2
20	464.051.002	Clamp plate		2
21	406.120.604	Distance bush Ø16/Ø12 L=60		2
22	406.120.800	Distance bush Ø16/Ø12 L=80		2
23	804.080.120	Bolt M8 x 12 - ISO 4017		4
24	802.120.850	Bolt M12 x 85 - ISO 4014		2
25	802.121.100	Bolt M12 x 110 - ISO 4014		2

Till serial no H2192202

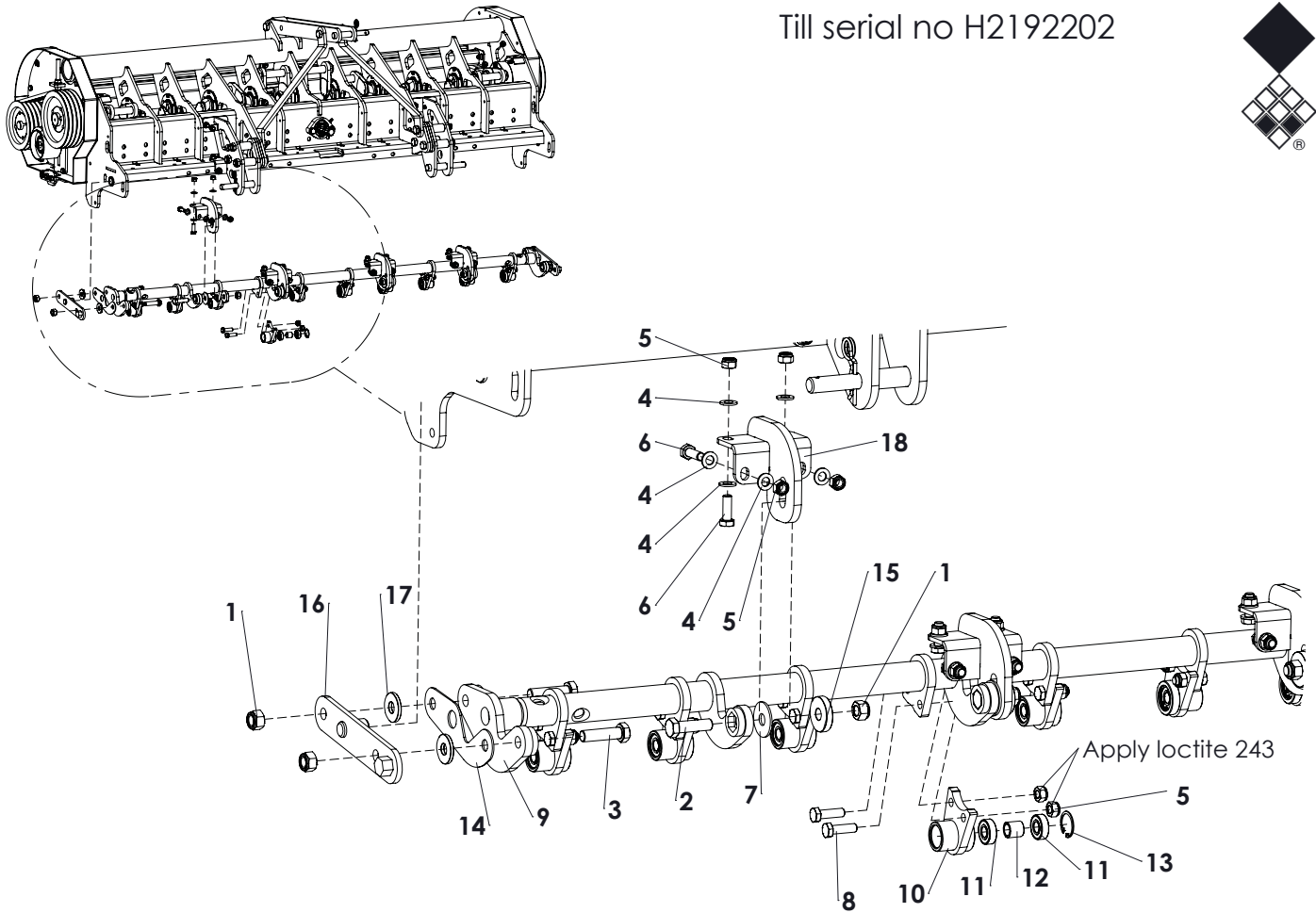

Placements of bearing supports

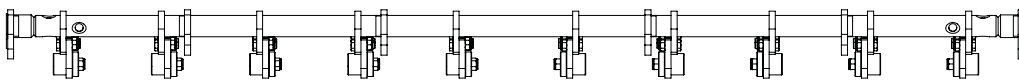

ITEM	PART NUMBER	DESCRIPTION	REMARKS	QUA
1	830.160.160	Self Lock Nut M16 10.9 - ISO 10511		8
2	804.160.550	Bolt M16 x 55 - ISO 4017		4
3	802.160.600	Bolt M16 x 60 - ISO 4014 - 10.9		4
4	864.120.030	Washer M12 - ISO 7089		32
5	830.120.120	Self Lock Nut M12 - ISO 10511 Class 10.9		26
6	804.120.350	Bolt M12 x 35 - ISO 4017		16
7	864.160.031	Large washer M16 - DIN 9021		4
8	804.120.402	Bolt M12 x 40 - ISO 4017 Class 10.9		20
9	478.151.922	Central bar		1
10	470.120.500	Bearing support		10
11	713.150.110	Bearing 6202-LLU		20
12	406.160.222	Bush		10
13	872.035.150	Circlip D=35 - DIN 472		10
14	468.032.052	Spacer		2
15	402.160.100	Distance washer Ø16.5/Ø50 L=10		4
16	466.080.275	Handle		2
17	402.160.050	Distance bush Ø42/Ø16 L=5		4
18	470.121.400	Central bar support		4

Both sides of drive are similar

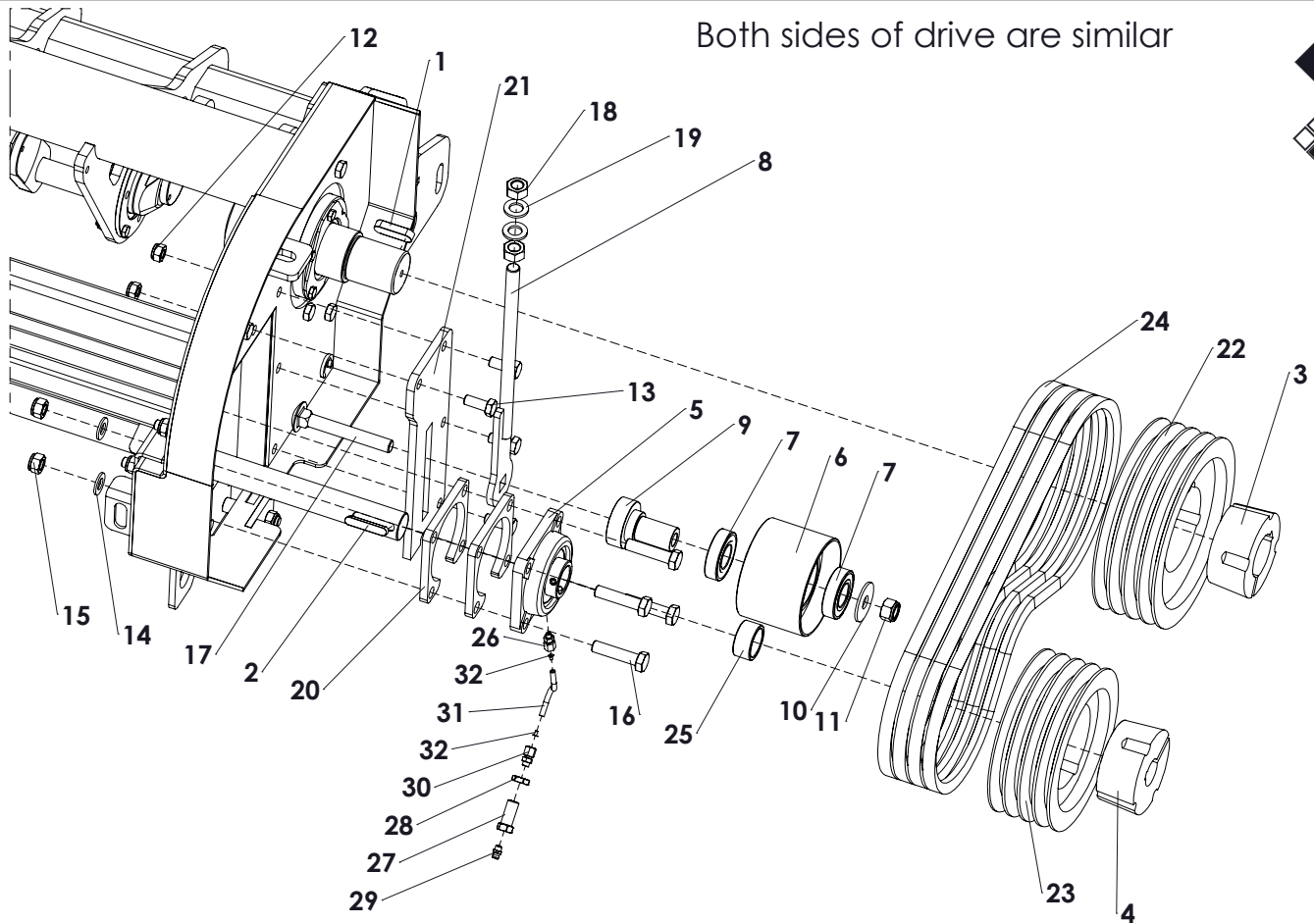

ITEM	PART NUMBER	DESCRIPTION	REMARKS	QUA
1	884.160.500	Key 16x10x50 DIN 6885		2
2	884.100.550	Key 10x8x55 - DIN 6885		2
3	648.553.020	Taperlock 3020 - 55mm		2
4	648.353.020	Taperlock 3020 - 35mm		2
5	741.350.430	Bearing UCF 207		2
6	428.851.250	Idler		2
7	713.300.160	Bearing DIN 6206 2RS		4
8	470.081.950	Tensioner		2
9	404.120.750	Distance bush		2
10	864.160.031	Large washer M16 - DIN 9021		2
11	830.160.160	Self Lock Nut M16 10.9 - ISO 10511		2
12	830.120.120	Self Lock Nut M12 - ISO 10511 Class 10.9		8
13	804.120.300	Bolt M12 x 30 - ISO 4017		8
14	864.140.030	Washer M14 - ISO 7089		8
15	830.140.140	Self Lock Nut M14 10.9 - ISO 10511		8
16	802.140.600	Bolt M14 x 60 - ISO 4014		8
17	820.161.200	MH Bolt M16 x 120 ISO 8677		2
18	826.160.160	Nut M16 - DIN 934		4
19	864.160.030	Washer M16 - ISO 7089		4
20	468.101.171	Spacer		4
21	468.103.802	Spanner plate		2
22	646.023.600	Pulley SPB 236-4 T3020		2
23	646.020.004	Pulley SPB 200-4 T3020		2
24	631.614.000	SPB 1400 Red Power III		8
25	402.360.230	Distance bush Ø36 / Ø45 L=22.5		2
26	596.120.244	Grease nipple connector		2
27	596.140.270	Bulkhead coupling		2
28	844.140.060	Nut M14x1.5		2
29	880.080.100	Grease nipple M8 DIN 71412A		2
30	596.120.240	Grease nipple connector		2
31	596.061.000	Grease hose L=100mm		2
32	596.060.060	Connector		4

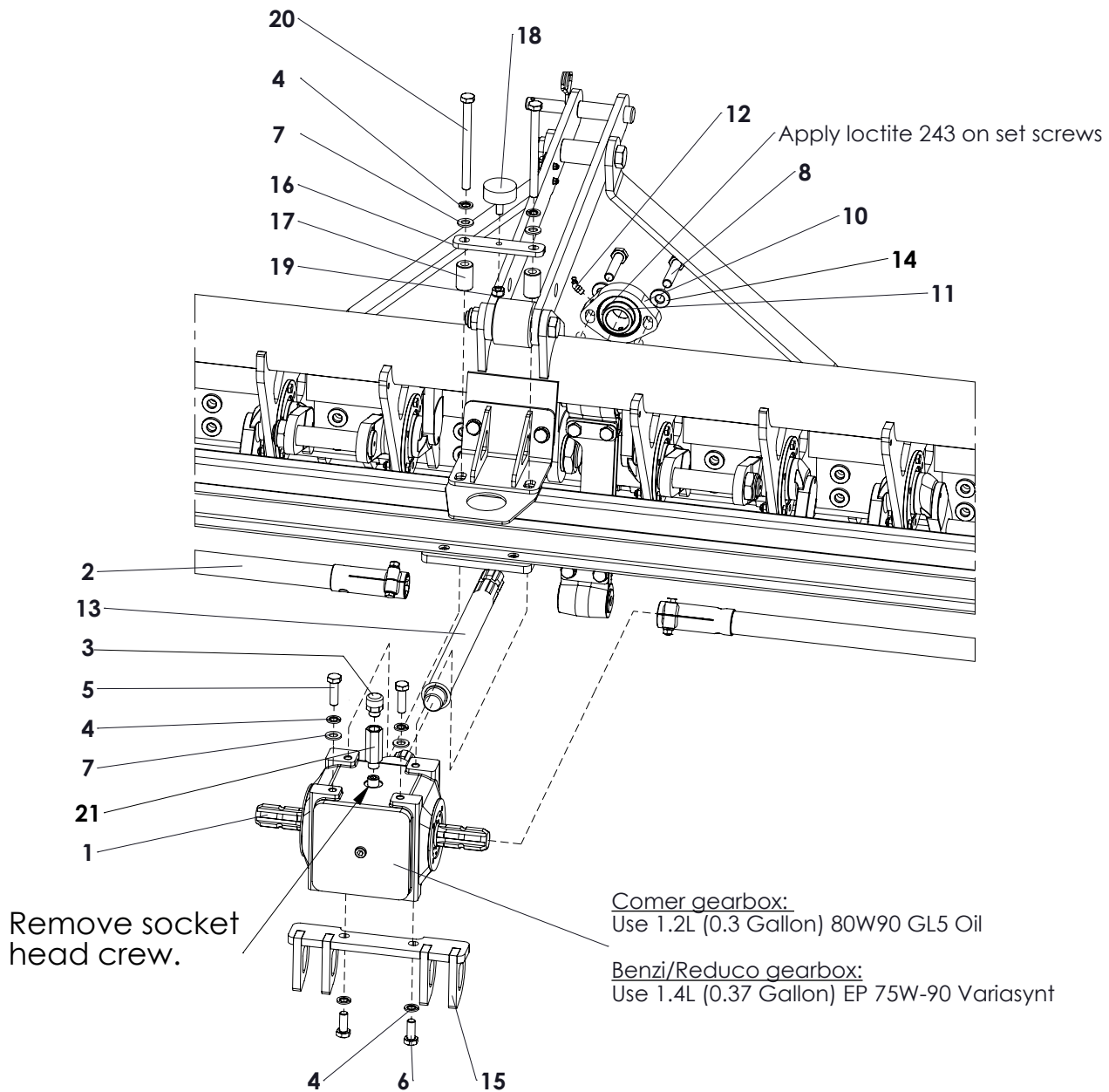

ITEM	PART NUMBER	DESCRIPTION	REMARKS	QUA
1	622.175.206	Comer T-27A 267.006 1:1	Check the brand / type	1
	622.175.206 RE	Gearbox Reduco R140 1:1	Check the brand / type	1
2	474.359.900	Drive shaft		2
3	537.380.360	Breather 3/8" BSP	Comer	1
	537.160.320	Breather 1/2" BSP	Benzi	1
4	866.120.020	Spring Washer M12 - DIN 127		6
5	804.120.402	Bolt M12 x 40 - ISO 4017 Class 10.9		2
6	804.120.300	Bolt M12 x 30 - ISO 4017		2
7	864.120.030	Washer M12 - ISO 7089		4
8	802.140.700	Bolt M14 x 70 - ISO 4014 Class 10.9		2
9	830.140.140	Self Lock Nut M14-ISO 10511 Class 10		1
10	468.251.200	Bearing house		1
11	745.350.430	Bearing UC207		1
12	880.080.104	Grease nipple M8 45deg. DIN 71412B		1
13	474.355.200	Drive shaft		1
14	412.050.300	Washer		2
15	470.122.740	Gearbox protector		1
16	468.081.406	Support strip		1
17	406.130.400	Distance bush Ø25/Ø12.5 L=40		2
18	D208112001	Rubber stop		1
19	830.100.100	Self Lock Nut M10 - ISO 10511		1
20	802.121.500	Bolt M12 x 150 - ISO 4014		2
21	543.170.176	Extension nipple G3/8"xG3/8" L=54mm	Only use with Comer gearbox	1

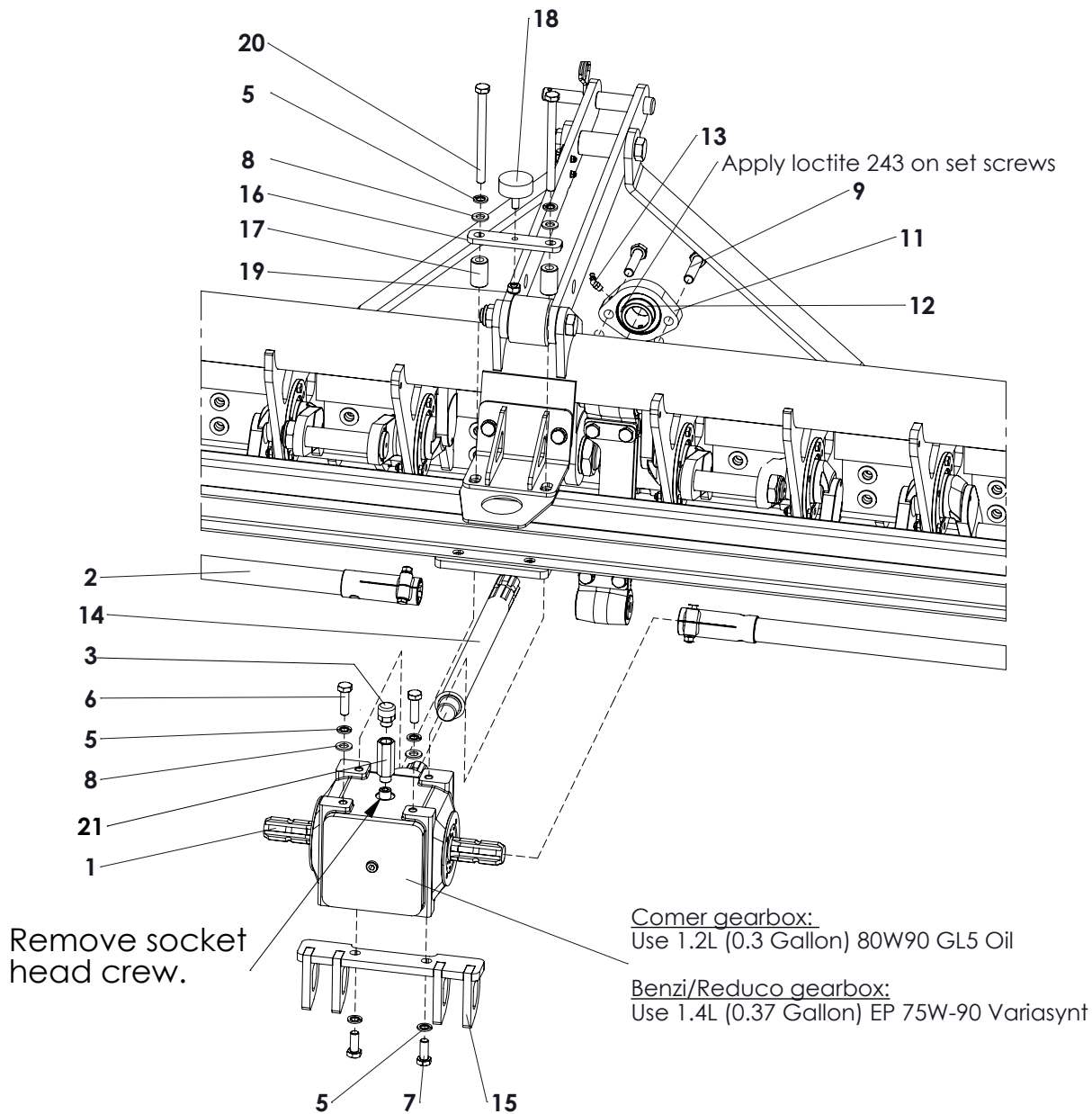

ITEM	PART NUMBER	DESCRIPTION	REMARKS	QUA
1	622.175.206	Comer T-27A 267.006 1:1	Check the brand / type	1
	622.175.206 RE	Gearbox Reduco R140 1:1	Check the brand / type	1
2	474.359.900	Drive shaft		2
3	537.380.360	Breather 3/8" BSP	Comer	1
4	537.160.320	Breather 1/2" BSP	Benzi	1
5	866.120.020	Spring Washer M12 - DIN 127		6
6	804.120.402	Bolt M12 x 40 - ISO 4017 Class 10.9		2
7	804.120.300	Bolt M12 x 30 - ISO 4017		2
8	864.120.030	Washer M12 - ISO 7089		4
9	802.140.650	Bolt M14 x 65 - ISO 4014 - 10.9		2
10	830.140.140	Self Lock Nut M14-ISO 10511 Class 10		1
11	468.251.200	Bearing house		1
12	745.350.430	Bearing UC207		1
13	880.080.104	Grease nipple M8 45deg. DIN 71412B		1
14	474.355.200	Drive shaft		1
15	470.122.740	Gearbox protector		1
16	468.081.406	Support strip		1
17	406.130.400	Distance bush Ø25/Ø12.5 L=40		2
18	D208112001	Rubber stop		1
19	830.100.100	Self Lock Nut M10 - ISO 10511		1
20	802.121.500	Bolt M12 x 150 - ISO 4014		2
21	543.170.176	Extension nipple G3/8"xG3/8" L=54mm	Only use with Comer gearbox	1

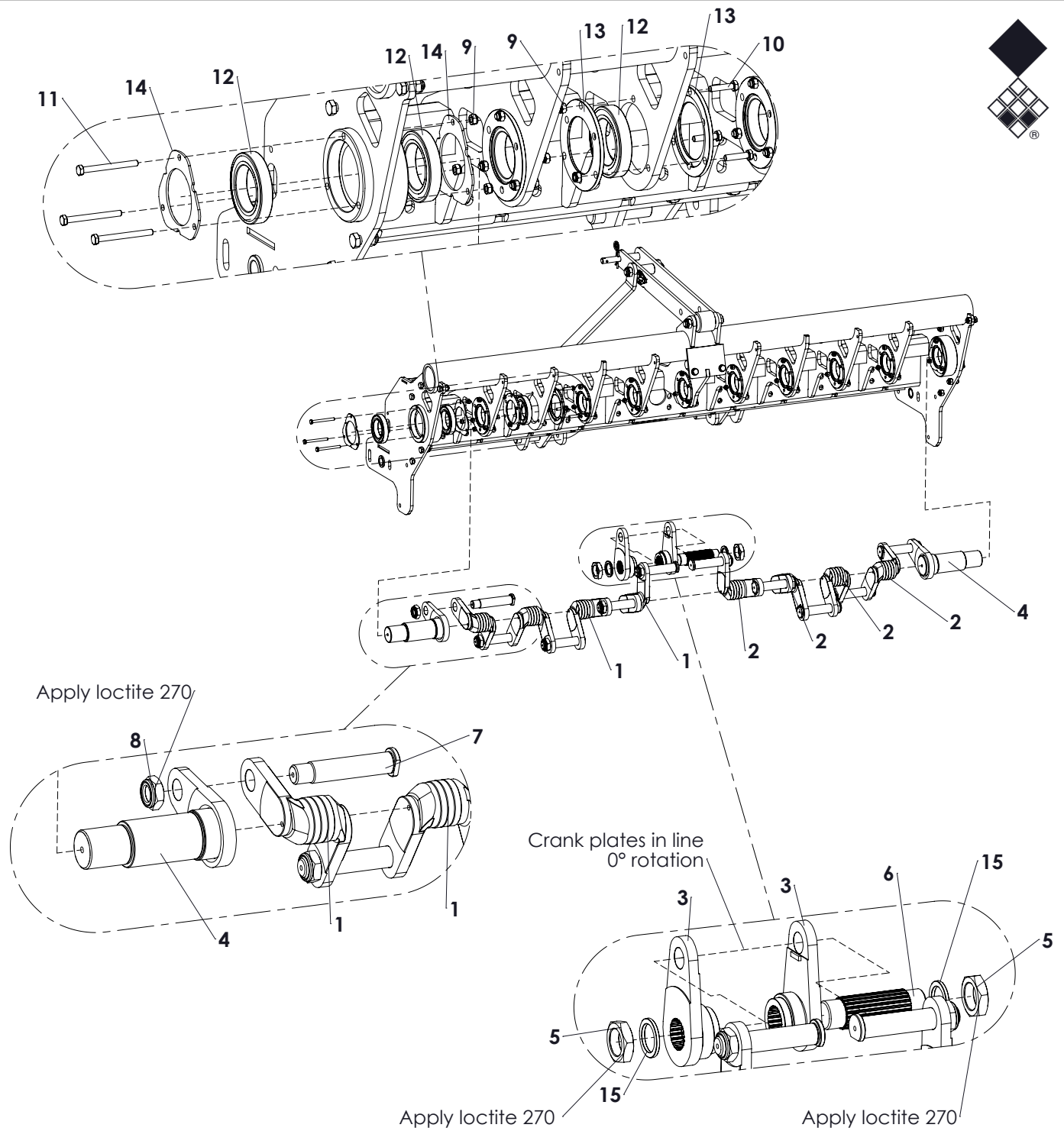

ITEM	PART NUMBER	DESCRIPTION	REMARKS	QUA
1	498.172.160	Crank left		4
2	498.172.162	Crank Right		4
3	470.151.800	Splined crank plate		2
4	470.181.870	Crank plate		2
5	4109600	Crank shaft nut M40x1.75		2
6	420.651.300	Splined shaft		1
7	416.301.520	Big end pin		10
8	834.270.180	Self lock nut M27 Grade 10.9		10
9	830.080.080	Self Lock Nut M8 - ISO 10511		33
10	804.080.350	Bolt M8 x 35 - ISO 4017		27
11	802.080.850	Bolt M8 x 85 - ISO 4014		6
12	713.650.180	Bearing 6013 LLU		13
13	468.061.280	Cover		18
14	468.031.308	Crank cover big hole		4
15	406.400.052	Distance bush Ø55/Ø40.2 L=5		2

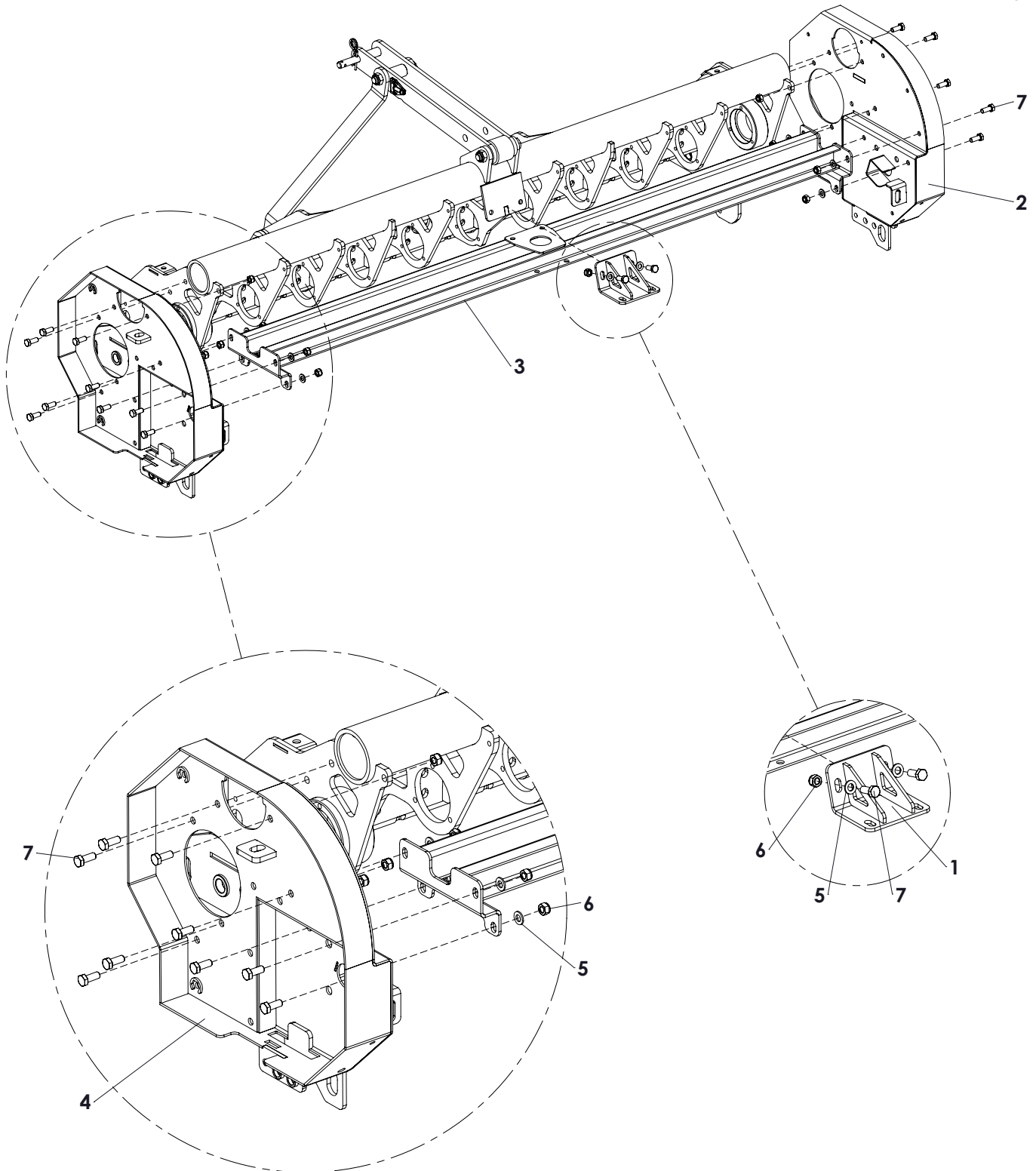

ITEM	PART NUMBER	DESCRIPTION	REMARKS	QUA
1	494.014.012	Bracket		1
2	494.062.061	Cover		1
3	494.204.023	Subframe		1
4	494.062.062	Cover		1
5	864.120.030	Washer M12 - ISO 7089		10
6	830.120.120	Self Lock Nut M12 - ISO 10511 Class 10.9		20
7	804.120.300	Bolt M12 x 30 - ISO 4017		20

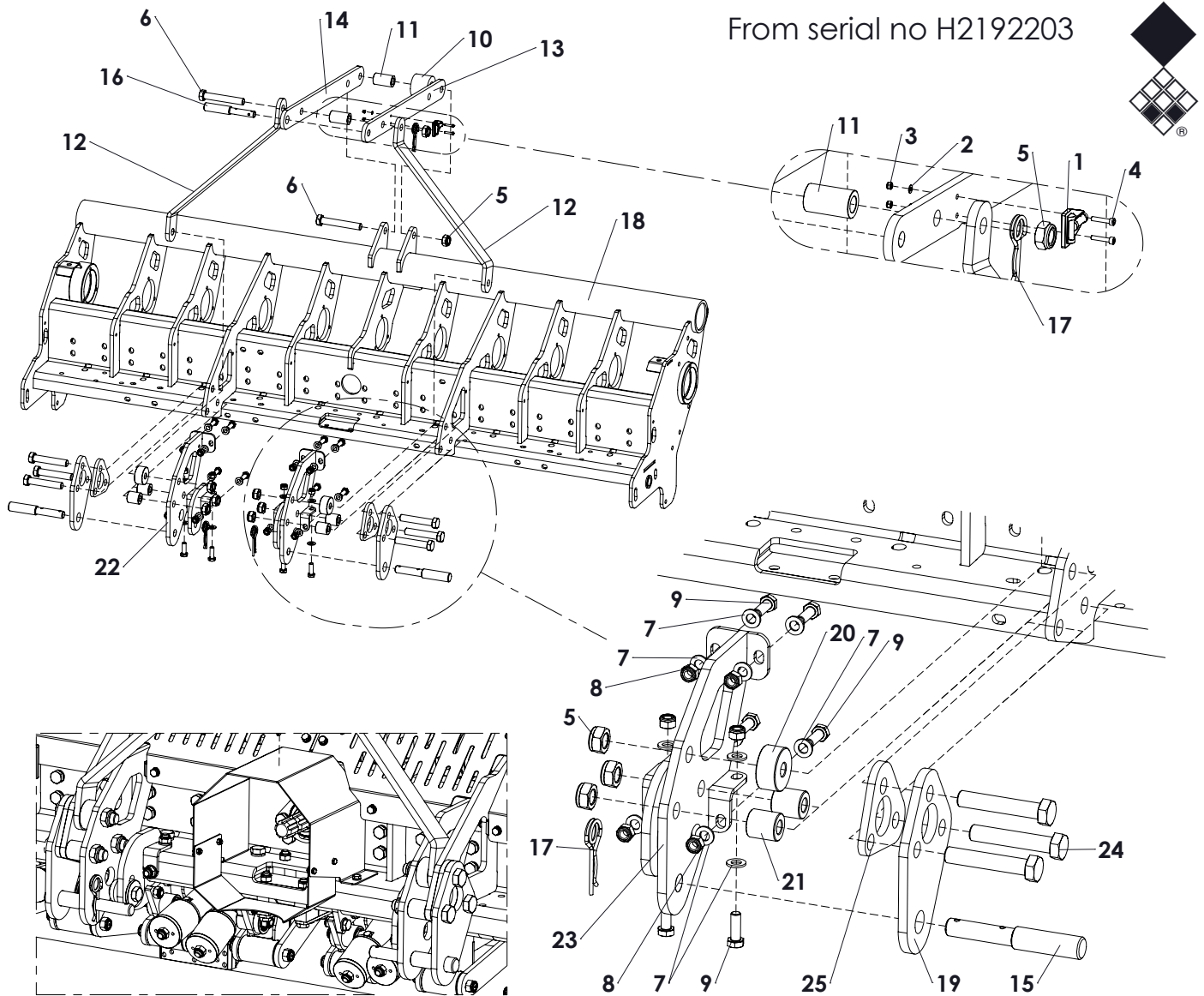





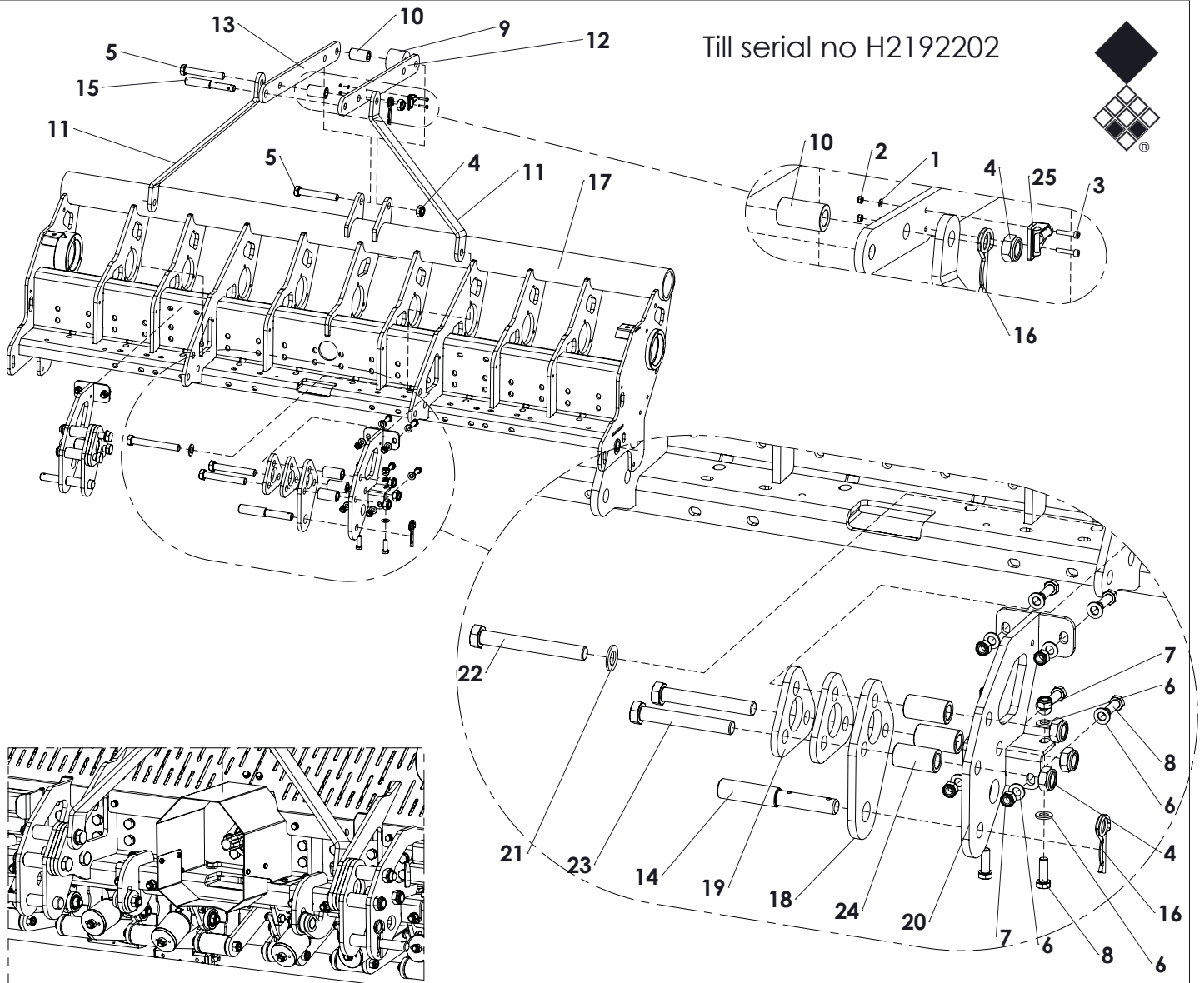



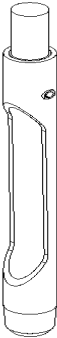

ITEM	PART NUMBER	DESCRIPTION	REMARKS	QUA
1	599.023.600	Dual water level		1
2	864.050.030	Washer M5 - ISO 7089		2
3	830.050.050	Self Lock Nut M5 - ISO 10511		2
4	814.050.250	DIN 912 M5 x 25 --- 25C		2
5	830.200.200	Self Lock Nut M20 Din 985 h=17		8
6	802.201.300	Bolt M20 x 130 - ISO 4014		2
7	864.120.030	Washer M12 - ISO 7089		24
8	830.120.120	Self Lock Nut M12 - ISO 10511 Class 10.9		12
9	804.120.350	Bolt M12 x 35 - ISO 4017		12
10	446.700.550	Rubber stop		1
11	406.210.600	Distance bush		2
12	464.126.110	Support arm		2
13	464.125.802	Top link strip right		1
14	464.125.800	Top link strip left		1
15	521.221.600	3-point pin		2
16	521.191.600	Top link pin OS		1
17	523.051.000	R-clip Round 5, DIN 11024		3
18	494.207.062	Frame VD2519		1
19	468.122.300	3-Point plate		2
20	406.170.260	Distance bush Ø55/Ø17 L=26		2
21	406.170.382	Distance bush Ø17/Ø35 L=38		4
22	470.122.602	3-Point bracket left		1
23	470.122.604	3-Point bracket right		1
24	802.201.100	Bolt M20 x 110 - ISO 4014		6
25	468.101.320	Spacer		2

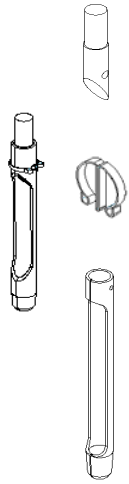
Till serial no H2192202

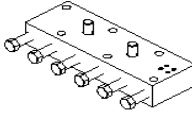
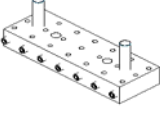
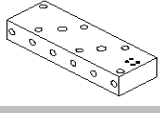
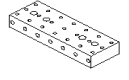

ITEM	PART NUMBER	DESCRIPTION	REMARKS	QUA
1	864.050.030	Washer M5 - ISO 7089		2
2	830.050.050	Self Lock Nut M5 - ISO 10511		2
3	814.050.250	DIN 912 M5 x 25 --- 25C		2
4	830.200.200	Self Lock Nut M20 Din 985 h=17		8
5	802.201.300	Bolt M20 x 130 - ISO 4014		2
6	864.120.030	Washer M12 - ISO 7089		24
7	830.120.120	Self Lock Nut M12 - ISO 10511 Class 10.9		12
8	804.120.350	Bolt M12 x 35 - ISO 4017		12
9	446.700.550	Rubber stop		1
10	406.210.600	Distance bush		2
11	464.126.110	Support arm		2
12	464.125.802	Top link strip right		1
13	464.125.800	Top link strip left		1
14	521.221.600	3-point pin		2
15	521.191.600	Top link pin OS		1
16	523.051.000	R-clip Round 5, DIN 11024		3
17	494.207.062A	Frame VD2519		1
18	468.122.300	3-Point plate		2
19	468.101.406	Spacer		4
20	470.122.600	3-Point bracket		2
21	864.200.030	Washer M20 - ISO 7089		2
22	802.201.600	Bolt M20 x 160 - ISO 4014		2
23	802.201.400	Bolt M20 x 140 - ISO 4014		4
24	406.210.640	Distance bush		6
25	599.023.600	Dual water level		1

Solid tines							2519	
	Ø(mm)	Tine Size (mm)	Tine Size (inch)	Part #	Adapter		Qua	
	5	5 x 125	3/16 x 5	311.105.125	J or multi-tine block mini		30+J or 210 Q+V+X	
	8	8 x 150	5/16 x 6	311.108.150	K or multi-tine block		30+K or 60+M+U	
	8	8 x 175	5/16 x 7	9990056	K or multi-tine block		30+K or 60+M+U	
	8	8 x 250	5/16 x 10	9990059	K - Don't use in MTH. Will bend		30+K	
	12	12 x 150	1/2 x 6	311.112.150			30	
	12	12 x 200	1/2 x 8	311.112.200			30	
	12	12 x 225	1/2 x 9	311.112.225			30	
	12	12 x 250	1/2 x 10	2381837			30	
	18	18 x 200	3/4 x 8	311.118.200	L or non needed		20	
	18	18 x 225	3/4 x 9	311.118.225	L or non needed		20	
	18	18 x 250	3/4 x 10	2381841	L or non needed		20	
	Tines for verti-core							
	8	8x95	5/16 x 3 13/16	311.108.095	K or multi-tine block		30+K or 60+M+U	
	Hollow tines							2519
	Ø(mm)	Tine Size (mm)	Tine Size (inch)	Part #	Adapter		Qua	
	8	10 x 6 x 80	3/8 x 1/4 x 3	311.210.080	K or multi-tine block		30+K or 60+M+U	
	8	10 x 6 x 125	3/8 x 1/4 x 5	311.210.127	K or multi-tine block		30+K or 60+M+U	
	12	16 x 10 x 150	5/8 x 3/8 x 6	311.216.150			30	
	12	16 x 10 x 175	5/8 x 3/8 x 7	9990022			30	
	12	19 x 12 x 150	3/4 x 1/2 x 6	311.219.150			30	
	18	19 x 12 x 200	3/4 x 1/2 x 8	311.219.200			20	
	12	19 x 12 x 200	3/4 x 1/2 x 8	311.219.201			30	
	18	19 x 12 x 225	3/4 x 1/2 x 9	311.219.225			20	
	12	19 x 12 x 225	3/4 x 1/2 x 9	311.219.226			30	
	12	19 x 12 x 250	3/4 x 1/2 x 10	9990040			30	
	18	19 x 12 x 250	3/4 x 1/2 x 10	9990023			20	
	18	25 x 16 x 200	1 x 5/8 x 8	311.225.200			20	
	18	25 x 16 x 225	1 x 5/8 x 9	311.225.225			20	
	18	25 x 17 x 250	1 x 5/8 x 10	9990024			20	
	Replacement tubes							2519
		Ø(mm)	Tine Size (mm)	Tine Size (inch)	Part #	Combine with rollpin		Qua
		12	16 x 10 x 150	5/8 x 3/8 x 6	311.716.150	9990010		30
12		16 x 10 x 175	5/8 x 3/8 x 7	9990036	9990010		30	
12		19 x 12 x 150	3/4 x 1/2 x 6	311.719.150	9990012		30	
18		19 x 12 x 200	3/4 x 1/2 x 8	311.719.200	9990012		20	
12		19 x 12 x 200	3/4 x 1/2 x 8	311.719.200	9990012		30	
18		19 x 12 x 225	3/4 x 1/2 x 9	311.719.225	9990012		20	
12		19 x 12 x 225	3/4 x 1/2 x 9	311.719.225	9990012		30	
12		19 x 12 x 250	3/4 x 1/2 x 10	9990037	9990012		30	
18		19 x 12 x 250	3/4 x 1/2 x 10	9990037	9990012		20	
18		25 x 16 x 200	1 x 5/8 x 8	311.725.200	9990014		20	
18		25 x 16 x 225	1 x 5/8 x 9	311.725.225	9990014		20	
18		25 x 17 x 250	1 x 5/8 x 10	9990038	9990014		20	
Cross tines							2519	
	Ø(mm)	Tine Size (mm)	Tine Size (inch)	Part #	Adapter		Qua	
	8	12 x 90	1/2 x 3 1/2	9990020	K or multi-tine block		30 + K	
	12	12 x 90	1/2 x 3 1/2	311.812.090			30	
12	19 x 120	3/4 x 5	9990021			30		
Chisel tines							2519	
	Ø(mm)	Tine Size (mm)	Tine Size (inch)	Part #			Qua	
	12	4.8 x 19 x 175	3/16 x 3/4 x 7	311.619.175			30	
12	4.8 x 19 x 120	3/16 x 3/4 x 4 3/4	311.619.120			30		
Composed hollow tines							2519	
	Shank							
		Size (mm)	Size (inch)	Part #			Qua	
	A	12	1/2	311.120.690	(Straight)		30	
	B	18	3/4	311.180.782	(Straight)		20	
	C	12	1/2	311.180.780			30	
	D	24	1	311.240.862	(Straight)			
	E	18	3/4	311.240.860			20	
	Clip							
		Size (mm)	Size (inch)	Part #			Qua	
	F	16	5/8	438.160.160			30	
	G	22	7/8	438.220.220			30 / 20	
	H	30	1 3/16	438.300.300			20	
	Hollow tine tube (folded)							
		Tine Size (mm)	Tine Size (inch)	Part #			Qua	
		16 x 150	5/8 x 6	317.316.150	Combine with:	A and F	30A+30F	
		16 x 200	5/8 x 8	317.316.200	Combine with:	A and F	30A+30F	
		22 x 150	7/8 x 6	317.322.150	Combine with:	B or C and G	30B+30G	
							30C+30G	
	22 x 250	7/8 x 10	317.322.250	Combine with:	B or C and G	30B+30G		
						30C+30G		
	22 x 150	7/8 x 6	317.322.150	Combine with:	B or C and G	20B+20G		
						20C+20G		
	22 x 250	7/8 x 10	317.322.250	Combine with:	B or C and G	20B+20G		
						20C+20G		
	30 x 150	1 3/16 x 6	317.330.150	Combine with:	E and H	20E+20H		
	30 x 225	1 3/16 x 9	317.330.220	Combine with:	E and H	20E+20H		

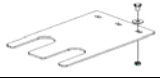
Adapter							2519	
	Tine Size (mm)	Tine Size (inch)	Part #				Qua	
	J	5	3/16	314.205.043			30	
	K	8	5/16	314.208.043			30	
Multi-tine block complete WO tines							2519	
	Tine Size (mm)	Tine Size (inch)	Part #			Tines:	Qua	
	8mm (5 tines)	5/16	211.700.016	Combination of:	T-O-U-Y-Z	A1-A3-A4-A5		
	8mm (6 tines)	5/16	9990206	Combination of:	M-U	A1-A2-A3-A4-A5	10 (60 tines)	
	8mm (8 tines)	5/16	9990208	Combination of:	N-U	A1-A2-A3-A4-A5		
	8mm (8 tines)	5/16	9990211	Combination of:	N-U-W	A1-A2-A3-A4-A5		
	8mm (8 tines)	5/16	314.430.209	Combination of:	P-U	A1-A2-A3-A4-A5		
	Tines:							
	A1	8 x 150	5/16 x 6	311.108.150	Solid tine			
	A2	8 x 175	5/16 x 7	9990056	Solid tine			
	A3	10 x 6 x 80	3/8 x 1/4 x 3	311.210.080	Hollow tine			
	A4	10 x 6 x 125	3/8 x 1/4 x 5	311.210.127	Hollow tine			
A5	12 x 90	1/2 x 3 1/2	9990020	Cross tine				
Multi-tine block mini needles complete WO tines							2519	
	Tine Size (mm)	Tine Size (inch)	Part #			Tines:	Qua	
	5	3/16	211.700.017	Combination off:	R-V	B1		
	5	3/16	314.425.170	Combination off:	Q-V-X	B1	10 (210 tines)	
	5	3/16	9990214	Combination off:	S-V-X	B1		
	Tines:							
B1	5 x 125	3/16 x 5	311.105.125	Needle tine				
Multi-tine block empty							2519	
	Tine Size (mm)	Tine Size (inch)	Part #				Qua	
	M	8mm (6 tines)	5/16	9990201			10	
	N	8mm (8 tines)	5/16	314.430.240				
	O	8mm (5 tines)	5/16	480.301.430				
P	8mm (8 tines)	5/16	211.215.002					
Multi-tine block mini needles empty							2519	
	Tine Size (mm)	Tine Size (inch)	Part #				Qua	
	Q	5 (21 tines)	3/16	480.251.740			10	
	R	5 (12 tines)	3/16	314.425.140				
S	5 (24 tines)	3/16	314.425.240					
Tine lock bolt							2519	
	Size (mm)		Part #				Qua	
	U	10x40		812.100.401			80	
		10x35		4001675				
Set screw							2519	
	Size (mm)		Part #				Qua	
	V	8x8		818.080.080			210	
Stud							2519	
	Size (mm)		Part #				Qua	
	W	23.2x50		408.230.500				
X	12x60		9990212D				20	
Turf hold down fingers							2519	
	Part name		Part #				Qua	
	Turf hold down finger MTH							
	Turf hold down finger 12mm		311.508.384				10	
Turf hold down finger 18mm		311.508.386				10		
Turf hold down kit							2519	
	Part name		Part #				Qua	
	THD kit complete MTH							
	THD kit complete 12mm		211.251.902				1	
THD kit complete 18mm		211.251.904				1		

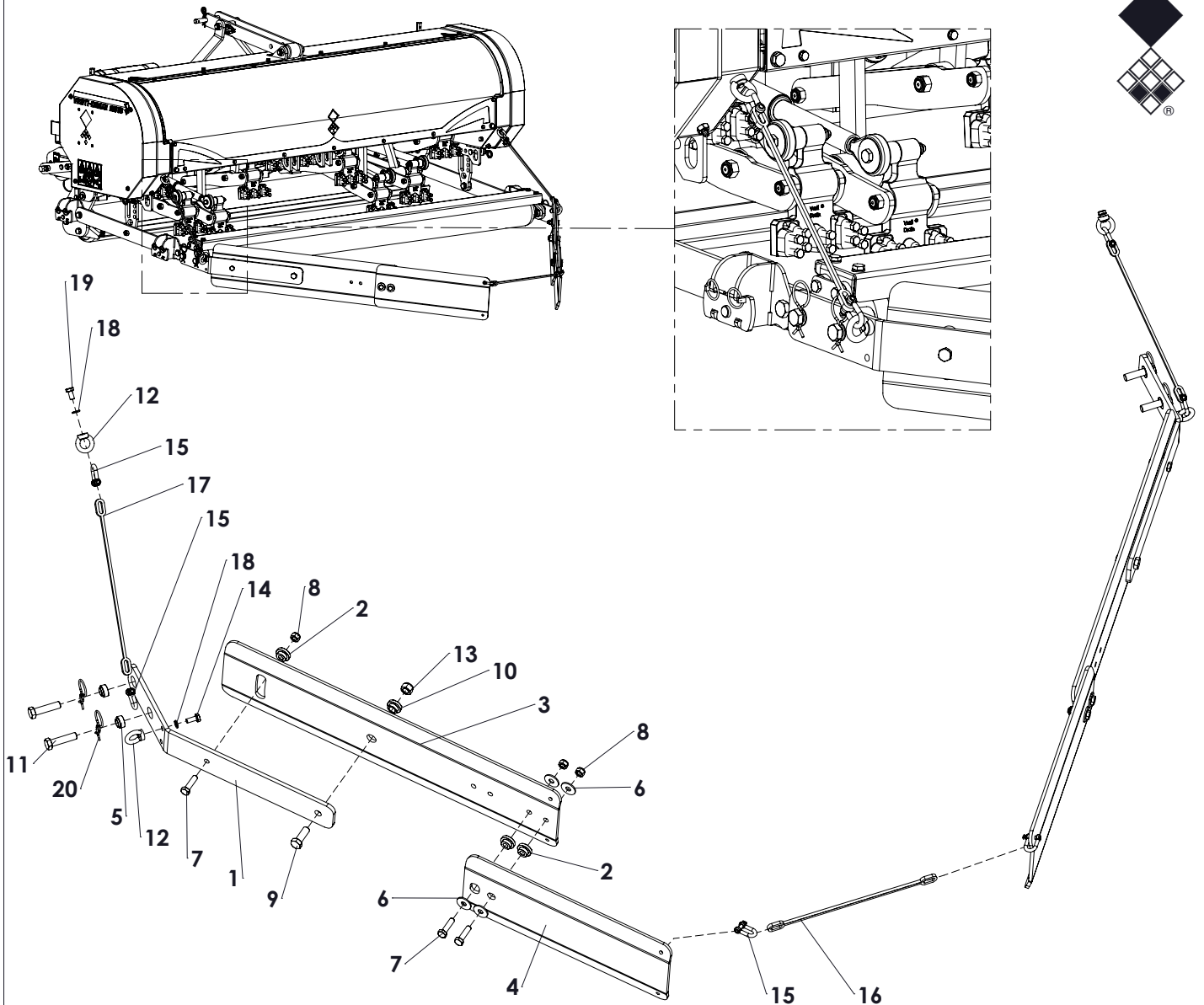

ITEM	PART NUMBER	DESCRIPTION	REMARKS	QUA
1	464.106.350	Window support		2
2	406.130.150	Distance bush		6
3	468.089.000	Window plate		2
4	468.085.500	Window plate extension		2
5	406.170.150	Distance bush		4
6	864.120.031	Large washer M12 - DIN 9021		8
7	804.120.450	Bolt M12 x 45 - ISO 4017		6
8	830.120.120	Self Lock Nut M12 - ISO 10511 Class 10.9		6
9	804.160.450	Bolt M16 x 45 - ISO 4017		2
10	406.160.150	Distance bush		2
11	802.160.650	Bolt M16 x 65 - ISO 4014 - 10.9		4
12	822.100.360	Eye Nut M10 DIN 582		4
13	830.160.160	Self Lock Nut M16 10.9 - ISO 10511		2
14	804.100.250	Bolt M10 x 25 - ISO 4017		2
15	846.080.241	D-Shackle D8		6
16	846.060.490	Chain 14 shackles L=490 (Shackle Ø6x35x9mm)		1
17	846.069.800	Chain 28 shackles L=980 (Shackle Ø6x35x9mm)		2
18	866.100.020	Spring Washer M10 - DIN 127		4
19	804.100.200	Bolt M10 x 20 - ISO 4017		2
20	523.030.752	Special R-clip d3		4
	211.251.908	Window kit VD2519	Contains items 1-20	

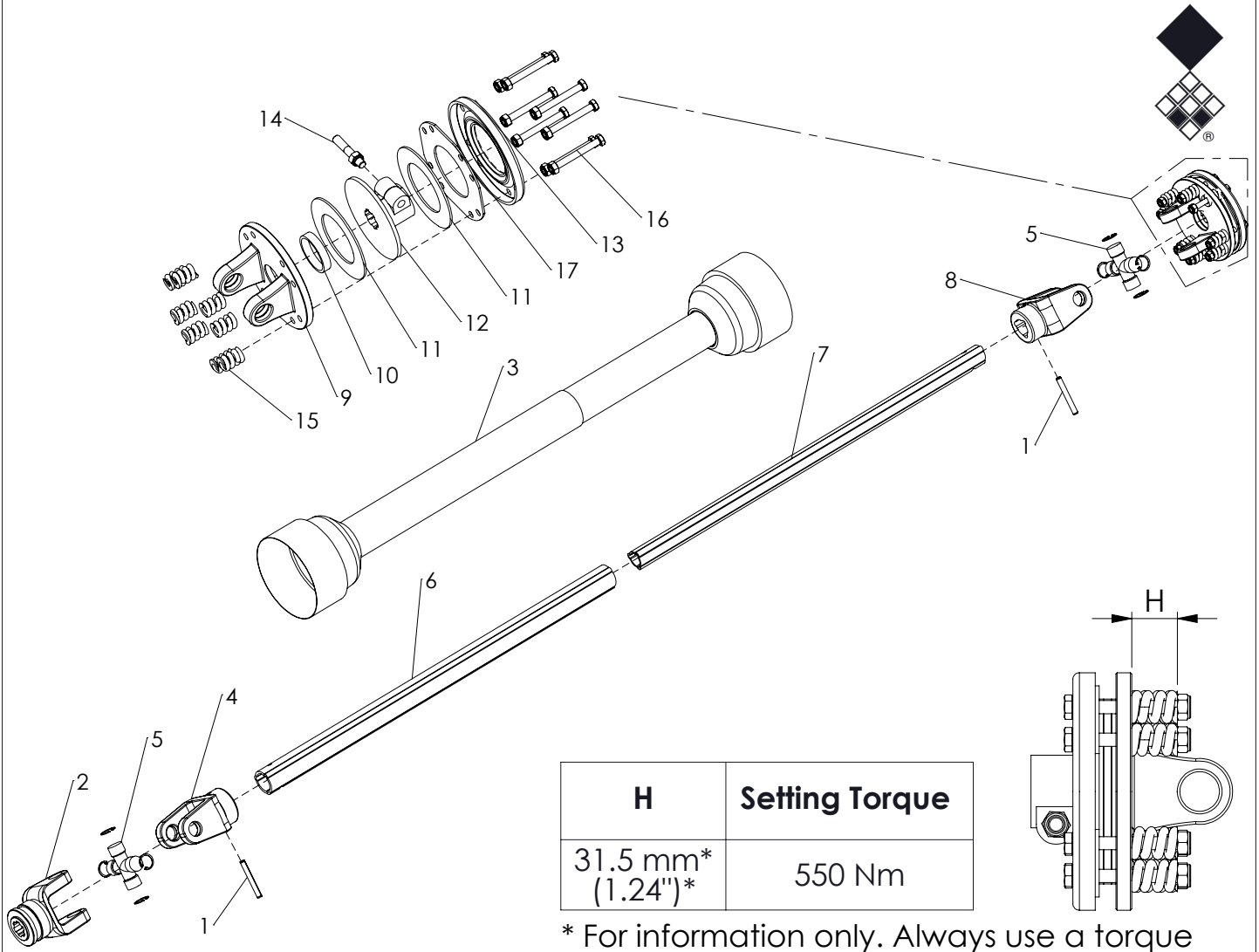

H	Setting Torque
31.5 mm* (1.24")*	550 Nm

* For information only. Always use a torque test rig to set the correct value.

ALWAYS deburr parts when cut
MEASURE correct length of PTO first
MAINTAIN slipclutch every month
NEVER USE PTO over 30 degrees
SLIPCLUTCH always on machine side

ITEM	PART NUMBER	DESCRIPTION	REMARKS	QUA
1	19000018	Outer roll pin		2
2	BEN PT140119	End yoke with quick lock		1
3	BEN PT143249	Safety guard group	Cut to correct length	1
4	BEN PT143666	Outer tube yoke		1
5	BEN PT151242	Universal joint assembled		2
6	BEN PT154926	Tubing cut to size	Cut to correct length	1
7	BEN PT157727	Tubing cut to size	Cut to correct length	1
8	BEN PT158836	Inner tube yoke		1
9	BEN F1B06	Flange yoke		1
10	BEN F060	Bush		1
11	BEN F030/S	Lining ring		2
12	BEN F138	Hub		1
13	BEN F1180	Pressure plate		1
14	BEN 90938	Conic bolt and nut		1
15	BEN F0111	Spring		8
16	BEN F10085	Bolt and nut		8
17	BEN F070	Inner plate		1
	611.601.200	PTO shaft type T-60 tl 1200		
	611.606.100	PTO shaft type T-60 tl 610		

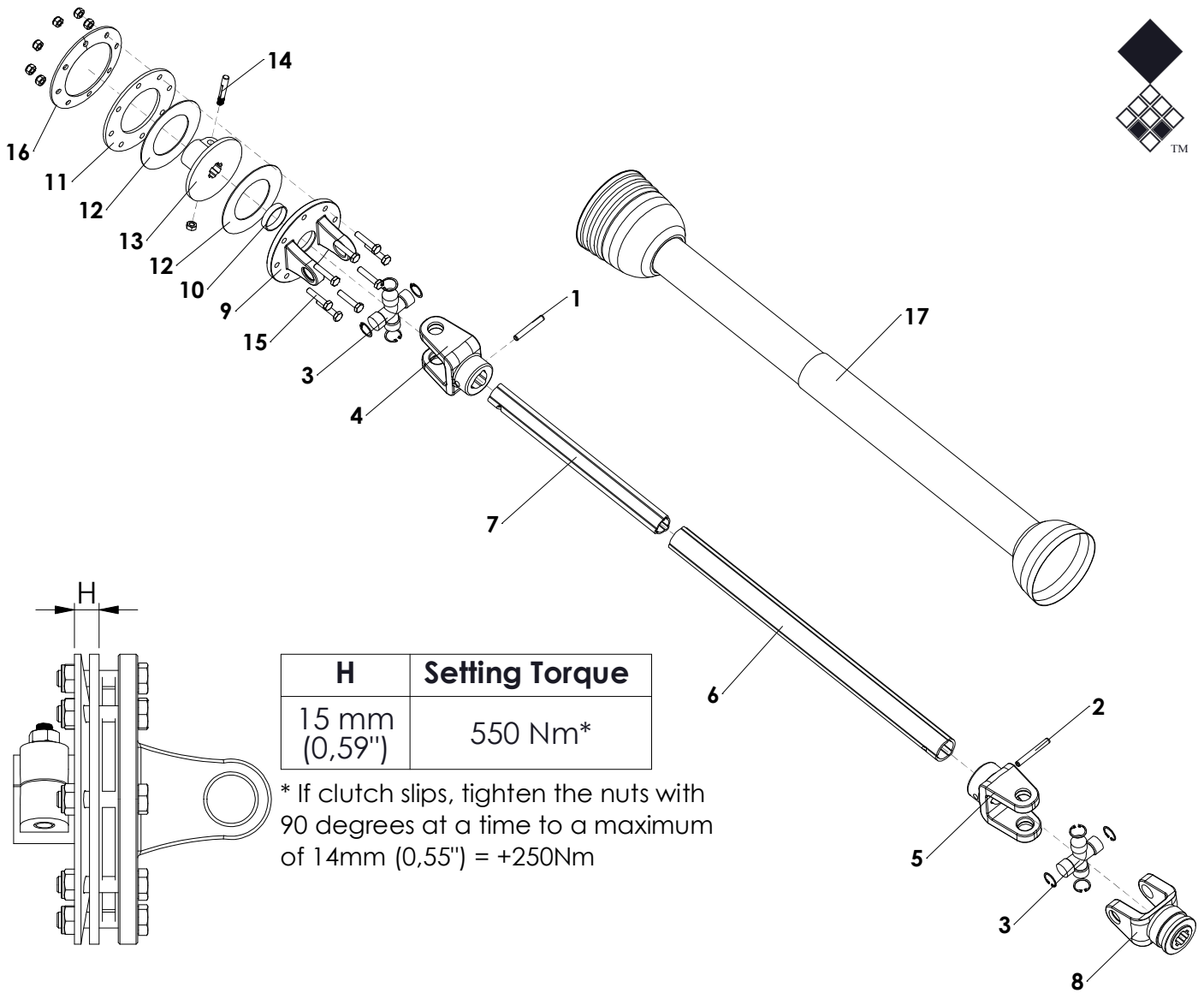

ALWAYS deburr parts when cut
MEASURE correct length of PTO first
MAINTAIN slipclutch every month
NEVER USE PTO over 30 degrees
SLIPCLUTCH always on machine side

ITEM	PART NUMBER	DESCRIPTION	REMARKS	QUA
1	19000016	Inner roll pin		1
2	19000018	Outer roll pin		1
3	180016130	Cross and 4x circlip kit		2
4	1510160291	Inner tube yoke type 60		1
5	1510160281	Outer tube yoke type 60		1
6	1521604610700	T60-series Outer tube	Cut to correct length	1
7	153150334	T60-series Inner tube	Cut to correct length	1
8	1410265441	Complete collar yoke type 60		1
9	1510168091	Flanged yoke T60		1
10	180015020	Bush		1
11	180017569	Pressure plate		1
12	180015019	Lining ring		2
13	1510169321	Hub T60		1
14	165000588	Tapered Pin 1 3/8" kit	Retighten every 40 hours	1
15	165000858	Bolt & nut M10 x 1,5 x 50		8
16	180017426	Belleville spring		1
17	1423600167651	Complete guard 60-series	Cut to correct length	1
	600610	Complete PTO T60		
	601010	Complete PTO T60		

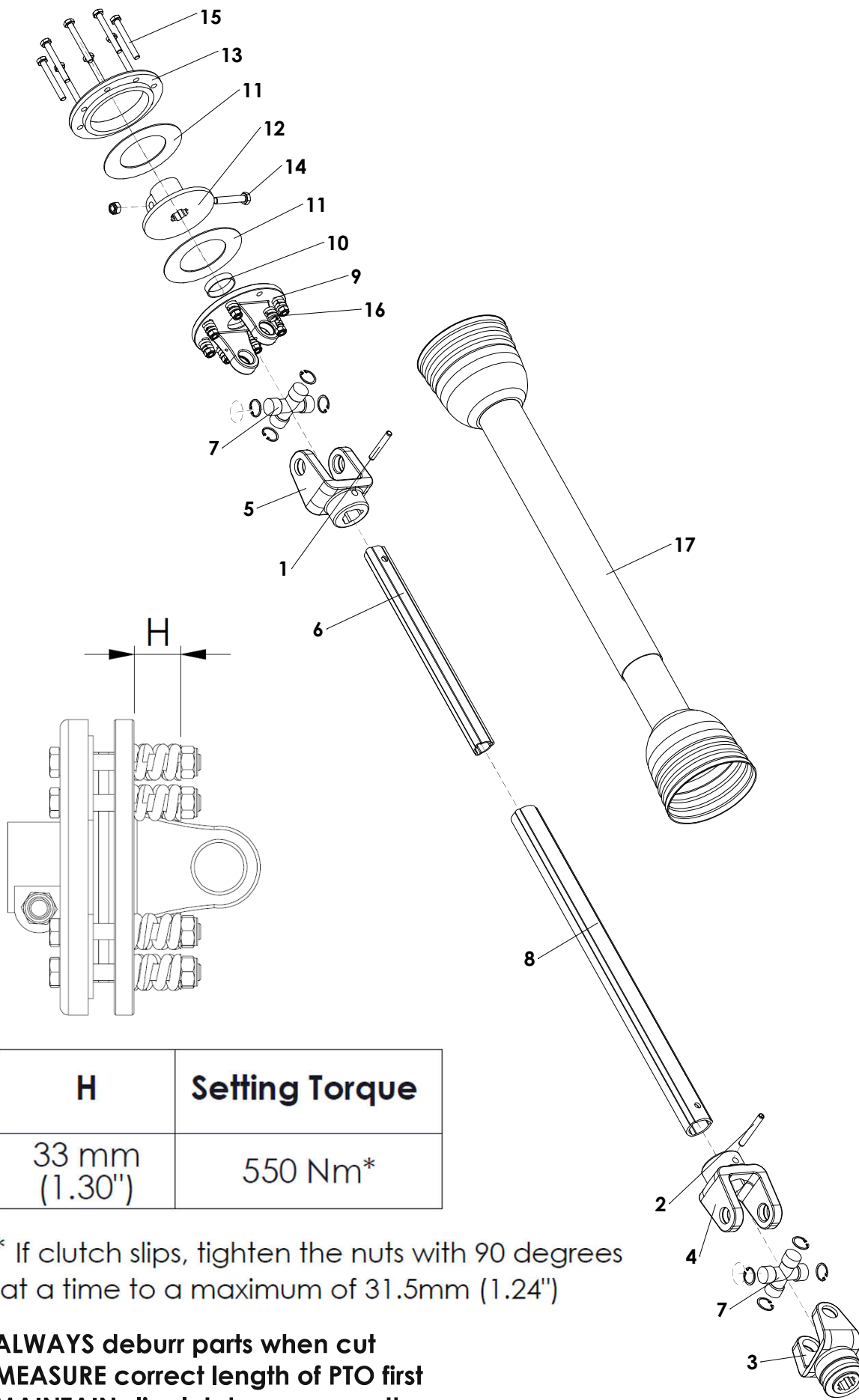

H	Setting Torque
33 mm (1.30")	550 Nm*

* If clutch slips, tighten the nuts with 90 degrees at a time to a maximum of 31.5mm (1.24")

ALWAYS deburr parts when cut
MEASURE correct length of PTO first
MAINTAIN slipclutch every month
NEVER USE PTO over 30 degrees
SLIPCLUTCH always on machine side

ITEM	PART NUMBER	DESCRIPTION	REMARKS	QUA
1	190000016	Inner roll pin		1
2	190000018	Outer roll pin		1
3	141026108	Complete collar yoke type 60		1
4	151016028	Outer tube yoke type 60		1
5	151016029	Inner tube yoke type 60		1
6	153160150	T60-series Inner tube		1
7	180016130	Cross and 4x circlip kit		2
8	152160475	T60-series Outer tube		1
9	151016039	Flanged yoke T60		1
10	180015020	Bush		1
11	180015019	Lining ring		2
12	151015018	Hub T60		1
13	180015021	Pressure plate		1
14	165000502	Bolt and Nut	Retighten every 40 hours	1
15	165000501	Bolt and nut		8
16	180014022	Spring		8
17	1422602987630	Complete guard 60-series	Cut to correct length	1
	600610	Complete PTO		
		ALWAYS deburr parts when cut		
		MEASURE correct length of PTO first		
		MAINTAIN slipclutch every month		
		NEVER USE PTO over 30 degrees angle		
		SLIPCLUTCH always on machine side		