



Verti-Air® 960



USER MANUAL



Translation of the original user manual

Version: UM145.960.000EN-2547

Applies to:

145.960.000 Verti-Air® 960



scan for manuals and product registration

Redexim B.V. | Kwekerijweg 8 | 3709 JA Zeist | The Netherlands
T: +31 (0)306 933 227 | E: redexim@redexim.com | W: www.redexim.com

EU - DECLARATION OF CONFORMITY



We,

Redexim B.V.

Kwekerijweg 8

3709 JA Zeist, The Netherlands

declare that this “EU - DECLARATION OF CONFORMITY” is issued under our sole responsibility and belongs to the following product:

VERTI-AIR® 960 WITH MACHINE NUMBER AS INDICATED ON THE MACHINE AND IN THIS MANUAL.

to which this declaration refers, complies with stipulation of:

2006/42/EC Machinery Directive

and with the standards:

ISO 12100-1:2010 Safety of machinery - General principles for design - Risk assessment and risk reduction

ISO 13857:2019 Safety of machinery - Safety distances to prevent hazard zones being reached by upper and lower limbs

ISO 4254-1:2015 Agricultural machinery - Safety - Part 1: General requirements

Zeist, 03-01-2022

A handwritten signature in blue ink, appearing to read 'C.H.G. de Bree', is written over a horizontal line.

C.H.G. de Bree

Redexim B.V.

UK - DECLARATION OF CONFORMITY



We,

Redexim B.V.
Kwekerijweg 8
3709 JA Zeist, The Netherlands

declare that this “UK - DECLARATION OF CONFORMITY” is issued under our sole responsibility and belongs to the following product:

VERTI-AIR® 960 WITH MACHINE NUMBER AS INDICATED ON THE MACHINE AND IN THIS MANUAL,

to which this declaration refers, complies with stipulation of:

S.I. 2008 No. 1597 HEALTH AND SAFETY The Supply of Machinery (Safety) Regulations 2008

and with the standards:

ISO 12100-1:2010 Safety of machinery - General principles for design - Risk assessment and risk reduction

ISO 13857:2019 Safety of machinery - Safety distances to prevent hazard zones being reached by upper and lower limbs

ISO 4254-1:2015 Agricultural machinery - Safety - Part 1: General requirements

Zeist, 03-01-2022

A handwritten signature in blue ink, appearing to read 'C.H.G. de Bree'.

C.H.G. de Bree
Redexim B.V.

FOREWORD

Congratulations on your Verti-Air® 960 purchase. For safe and long-lasting operation of this machine, it is necessary to read and to understand this user manual. It is impossible to work safely with this machine without complete knowledge of the content of the user manual.

This machine does not operate independently! It is the user's responsibility to use the correct tractor or other towing vehicle. The user should check the combination of the towing vehicle and the machine regarding various aspects, such as noise level and safety risks. In addition, the user should comply with the user instructions of the vehicle and spare parts that are used.

All information and technical specifications provided at the moment that this document is published are the most recent ones. Design specifications may be changed without prior notice.

In this user manual, the term "user" refers to any person operating the machine described herein.

You can contact your sales point or dealer if you have questions and/or if there are ambiguities in this manual or about the machine concerned.

This document is a translation of the original user manual. Upon request, the original user manual is available in Dutch.

WARRANTY CONDITIONS

The warranty, which applies to this product, is described in the "General sales and warranty conditions" under article 12 "Warranties" and is available on the Redexim website. You can use the QR code or URL below for this purpose.



<https://www.redexim.com/general-sales-and-delivery-conditions/>

PRODUCT REGISTRATION

Register your product with Redexim for faster technical support, notifications, exclusive news, offers and much more. You can use the QR code or URL below to do so.



<https://www.redexim.com/manuals-and-product-registration/>

TABLE OF CONTENTS

EU - DECLARATION OF CONFORMITY.....	2
UK - DECLARATION OF CONFORMITY	3
FOREWORD.....	4
WARRANTY CONDITIONS	4
PRODUCT REGISTRATION.....	4
1. SAFETY INSTRUCTIONS	6
1.1. Obligations of the user.....	6
1.2. Maintenance, repairs, and adjustments.....	6
1.3. Using the machine	7
2. TECHNICAL DATA.....	8
3. GENERAL DESCRIPTION	8
4. SAFETY STICKERS	9
5. FIRST INSTALLATION.....	11
6. THE PTO SHAFT.....	13
6.1. Length of the PTO shaft.....	14
6.2. Using the PTO shaft	14
7. ATTACHING AND DETACHING THE MACHINE.....	15
7.1. Attaching the machine	15
7.2. Detaching the machine	16
8. TRANSPORT.....	17
9. PUTTING THE MACHINE INTO OPERATION	18
9.1. Safety.....	18
9.2. Running-in period	18
9.3. Working speed.....	19
9.4. Start/Stop procedure	19
10. TECHNICAL INFORMATION	21
10.1. Hydraulic control reverse spout.....	21
10.2. Outlet flap	21
11. MAINTENANCE.....	22
11.1. Maintenance schedule	22
11.2. V-belt tension	22
11.3. Cleaning	23
11.4. Lubrication points.....	23
12. TROUBLE SHOOTING.....	25

1. SAFETY INSTRUCTIONS



This machine is designed for safe use. This can only be achieved by strictly adhering to the safety instructions outlined in this manual.

Read and understand the manual before you start using this machine.

Failure to use the machine as described in this manual may result in personal injury and/or damage to the machine.

This user manual lists instructions that are numbered in sequence. You should follow this sequence.

The following signs are used in the manual:

-  indicates a safety instruction.
-  indicates a tip and/or note.

1.1. Obligations of the user

This machine is intended for blowing away leaves on large areas only. Any other use is improper. The manufacturer will not accept any liability for damage resulting from improper use. All risks occurring with this are entirely at the expense of the user.

All persons designated by the owner to operate, maintain, or repair the machine must have read and fully understood the operating instructions, particularly the chapter on Safety Instructions.

Modifications to the machine that have a negative impact on safety must be rectified immediately.

The user is obliged to check the machine for visible damage and defects before using the machine.

For safety reasons, it is not permitted to make changes or adjustments to the machine (except those approved by the manufacturer). If modifications to the machine have been made, then the current CE / UKCA marking is cancelled. The person who made these modifications must apply for a new CE / UKCA marking themselves.

Following the use, maintenance and repair instructions prescribed by the manufacturer are also considered proper use of this machine.

The user is responsible for the safe combination of the machine and the towing vehicle, which comply with the requirements as described in the Technical Data (see Chapter 2). This entire combination should be tested for noise, safety, risk and user friendliness. User instructions should also be drafted.

Dress appropriately during work activities with the machine. Wear sturdy shoes with steel toecaps, long trousers and tie up long hair. Do not wear loose clothing.

The general applicable health and safety regulations must also be followed in addition to the instructions in this user manual.

Relevant traffic regulations also apply in case of using public roads.

1.2. Maintenance, repairs, and adjustments

Keep a record of all the repair activities.

When unskilled persons use, maintain or repair the machine, this could result in injuries to the user and to third parties. This must be avoided!

Always use original Redexim parts for maintenance or repairs to ensure the safety of both the user and the machine.

Only authorized technical personnel may carry out repairs to the machine.

When carrying out maintenance, adjustments and repairs, it is necessary to block the machine in order to prevent it from sagging, driving off, and/or sliding off.

If a hydraulic installation is present, you should always make it pressure-free before working on this installation.

Used oil / grease is harmful to the environment. Dispose of these substances according to the local regulations.

1.3. Using the machine

Attach the machine to the towing vehicle according to the regulations. Pay attention to the risk of injury!

Never use the machine in the absence of protective guards and safety stickers.

Check the machine for loose nuts, bolts, and other components before every operation.

Check whether you have a clear field of vision – both close by and far away – before you start moving.

All persons operating the machine must be familiar with all the functions and control elements of the machine before starting any work activities.

Never crawl under the machine! If necessary, tip over the machine to work at the bottom side.

If present, regularly check and replace the hydraulic hoses when they are damaged or appear worn.

2. TECHNICAL DATA

Type	960
Recommended vehicle	60 HP with minimal lifting capacity 610 mm (24") behind the lifting eyes 425 kg (937 lbs)
Required PTO power	> 45 HP
PTO speed	540 RPM (CCW)
Working speed	Depending on the conditions and the required result
Weight	425 kg (937 lbs)
Dimensions (LxWxH)	1.25 x 1.42 x 1.5 m (49.2" x 55.9" x 59")
Three-point system	Cat. 1-2
Fan diameter	965 mm (38")
Air capacity	385 m ³ /min. (13.596 cu ft/min.)
Noise level	98 dB at 2500 RPM
Grease bearings	Ceran XM 220
Tire pressure	Max. 1.9 bar
Options	None

3. GENERAL DESCRIPTION

The Verti-Air® 960 is intended for blowing away leaves exclusively on large areas.

4. SAFETY STICKERS

Safety stickers are affixed to the machine. These safety stickers must always be clearly visible and legible and must be replaced if they become damaged (Fig. 1).

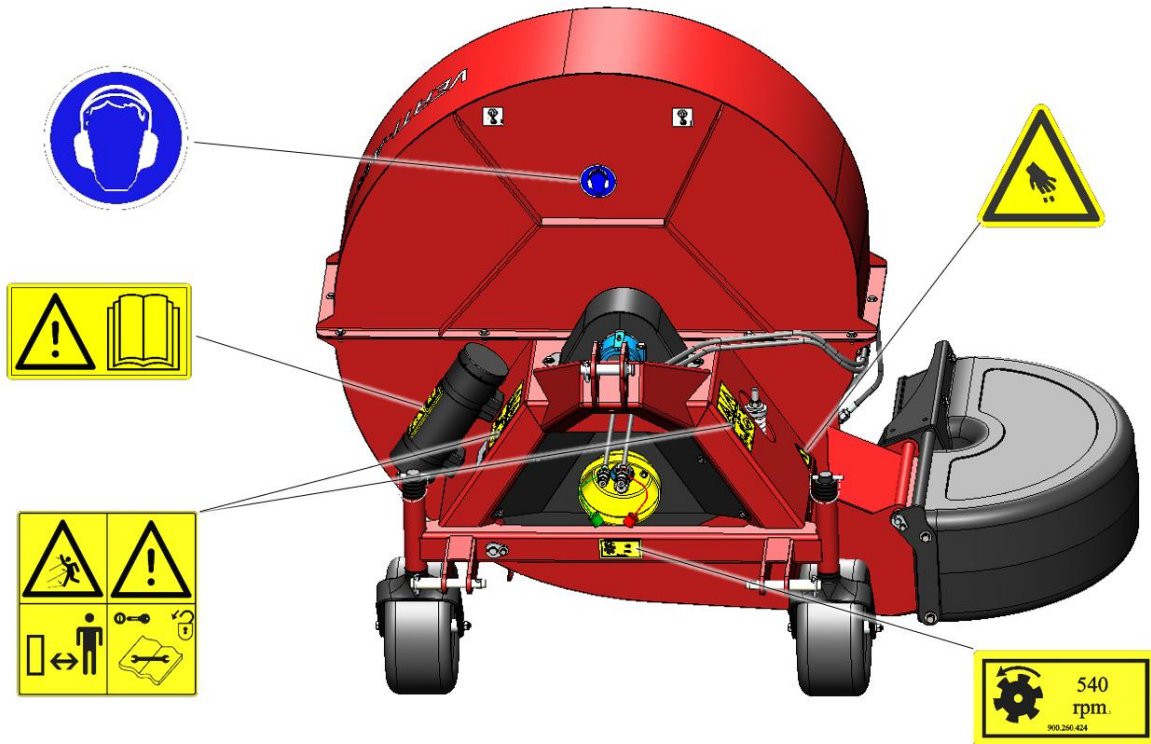







Fig. 1

 <p>933.280.402</p>	<ul style="list-style-type: none"> - In case of maintenance, adjustments and repair, always switch OFF the engine of the towing vehicle and the PTO. Secure the assembly to prevent it from rolling away or sliding. - Keep a minimum 4 meters distance if the machine is operating (except for the operator sitting in the towing vehicle). - During operation, NO persons are allowed within the danger zone of the machine because there is danger of physical injuries caused by moving components.
 <p>900.280.402</p>	<p>Prior to using the machine, the operators of the machine must read the user manual carefully.</p>
 <p>900.260.424</p>	<p>You can operate the machine safely if the PTO does not exceed 540 rpm.</p>

 <p>900.280.404</p>	<p>Be careful not to get any parts of your body jammed.</p>
 <p>911.340.410</p>	<p>Use certified hearing protection when using the machine.</p>

5. FIRST INSTALLATION

The machine should be prepared for use as follows (see Fig. 2, Fig. 3, and Fig. 4):

 **Make sure that the cable/crane/lift can lift at least 2x the weight of the machine.**

For the correct machine weight, see chapter 2, "Technical Data".

 **Never crawl under the machine.**

1. Remove the cross sections (1), PTO (2), and the box with parts (3) from the pallet.
2. Carefully lift the machine by the lifting points (4) and (5) to just above the pallet (6).

 **Keep a safe distance. The machine turns / slides away during hoisting / lifting.**

3. Remove the pallet (6) and lower the machine back onto the ground.
4. Remove the bracket (7) from the exhaust tunnel (8).
5. Reinstall the exhaust tunnel back on the machine in the indicated position. Now, the machine is ready for its first use.

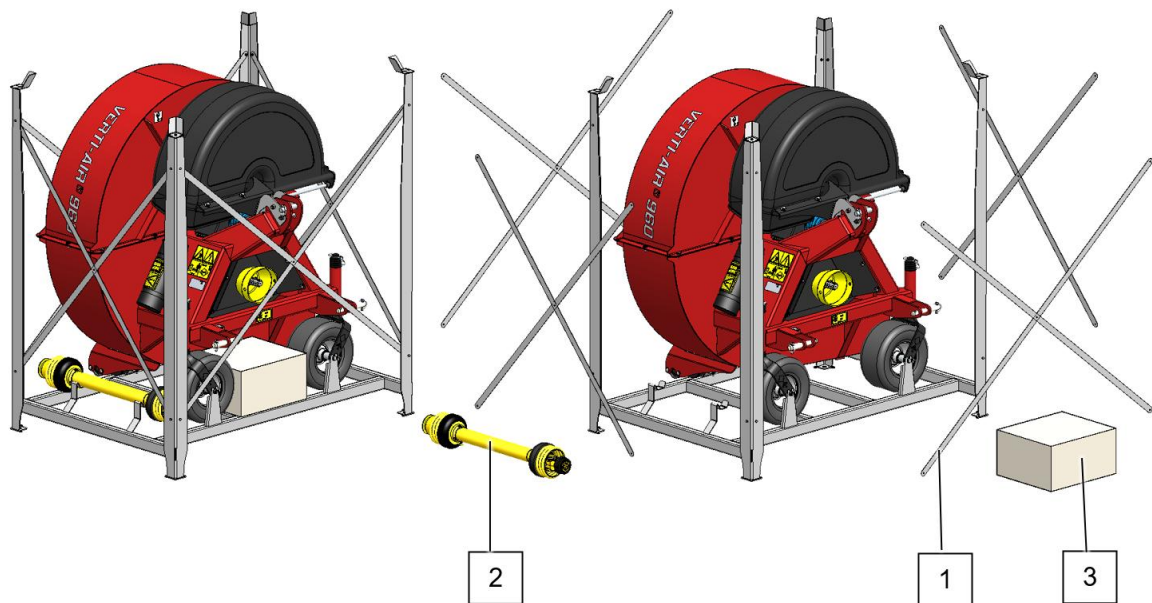

Fig. 2

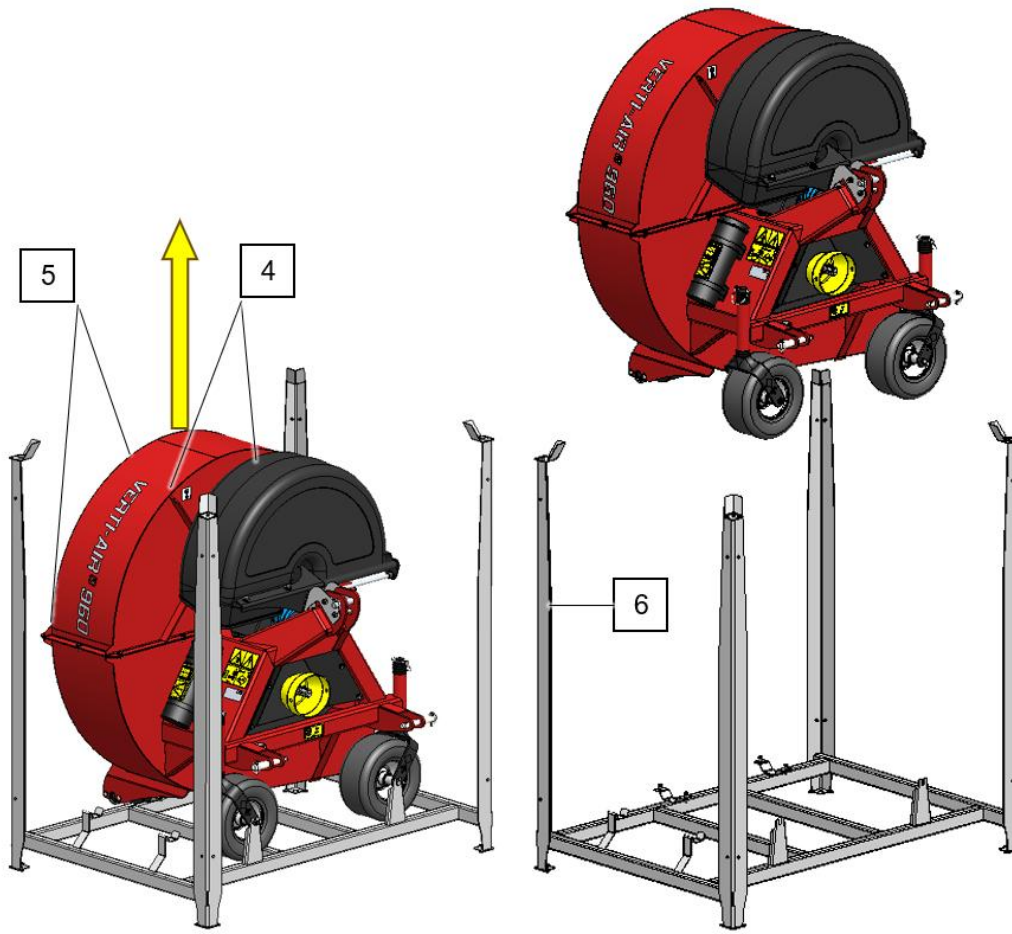

Fig. 3

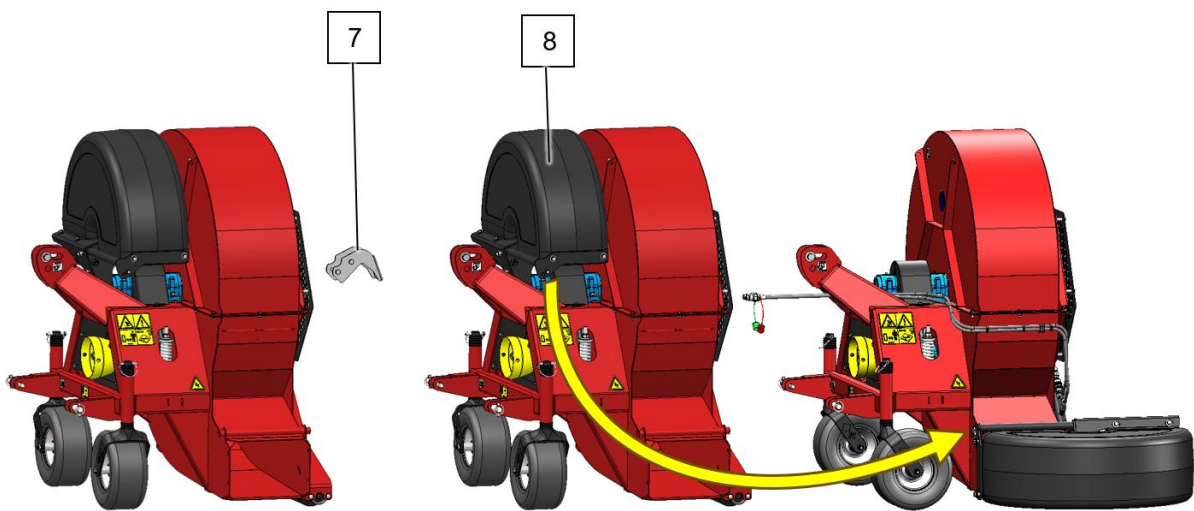



Fig. 4

6. THE PTO SHAFT

 The description below is only an indication of how to customize the PTO shaft. The instructions described in the specific manual supplied with the PTO shaft are always leading.

The PTO (power take-off) shaft is a very important component. It transmits power from the tractor to the machine. When properly maintained and installed, the PTO shaft ensures safe use of the machine. The PTO shaft has its own CE certification and manual. These are delivered together with the PTO shaft.

To make specific adjustments, follow the instructions outlined on the PTO page of the parts book.

Do not exceed the values given. This can lead to an unsafe situation and overload the machine, resulting in damage.

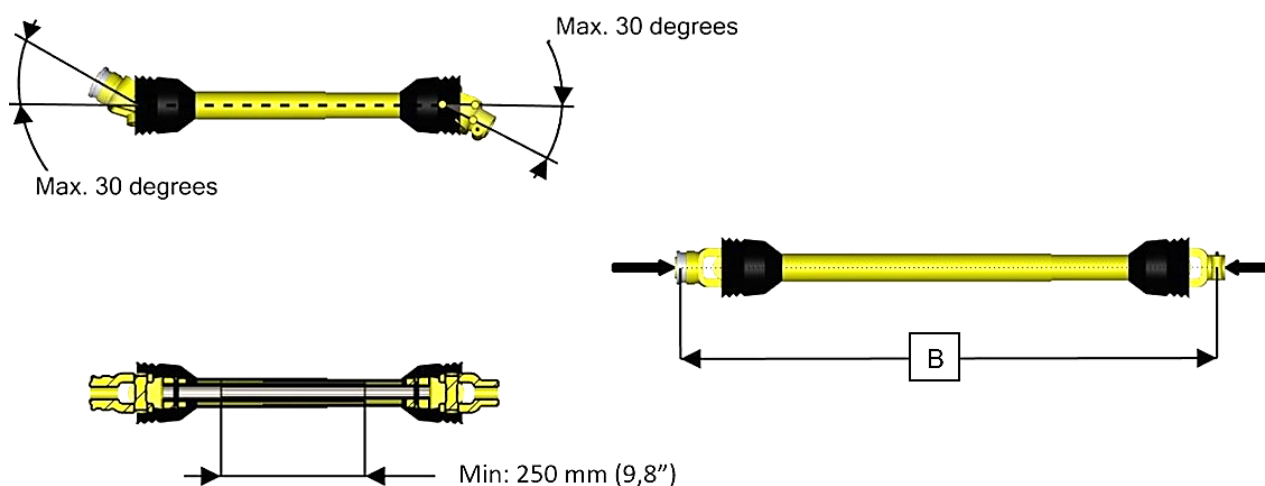
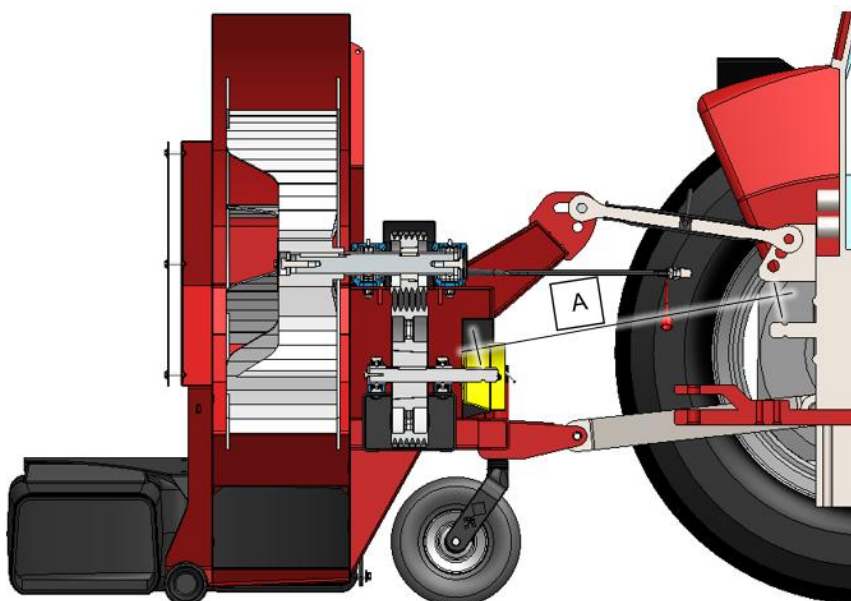

Fig. 5

6.1. Length of the PTO shaft

The length of the PTO shaft is very important. If it is too long, it can damage the tractor drive and/or the machine. If the overlapping length of the cylinders becomes less than 250 mm (9.8") at any time, it can damage the PTO shaft. The required length changes when the machine is lifted or when a different tractor is used! If a new machine is purchased or if another towing vehicle is used, the length of the PTO shaft should be checked and, if necessary, shortened (Fig. 5).

1. Measure the distance **A** (from groove to groove) between the tractor's PTO and the machine's connection point, when the machine is horizontal on the ground and the tractor is attached.
2. Measure the distance **B** of the PTO shaft in its shortest position from the locking pin to the locking bolt.
3. Divide the PTO shaft into two parts and remove the protection cap at both ends.
4. The ends of the cylinders and the protection caps should be shortened: $(B-A) + 125 \text{ mm}$ (4.9").
5. Smooth off the components with lubrication grease and then assemble them.
6. Mount the PTO shaft with the slip clutch on the machine side.
7. Attach the other end of the PTO shaft to the tractor.
8. Check the overlap of the cylinders.



Never use the machine if it has a damaged PTO protection cap. First replace the protection parts.



If the PTO is not shortened correctly or used in combination with a different vehicle this may cause damage to the gearbox.

6.2. Using the PTO shaft

The following items must be checked for correct use of the PTO shaft:

- The angle of the rotation points should always be smaller or equal to 30 degrees during work activities.
- The PTO shaft of the tractor must be parallel to the PTO shaft of the machine.
- The overlap of the cylinders must always be minimum 250 mm (9.8").
- Never use the machine if it has a damaged PTO protection cap.
- See the PTO manual for information about lubrication.

7. ATTACHING AND DETACHING THE MACHINE

Attaching and detaching the machine must be done carefully. Follow the instructions below:

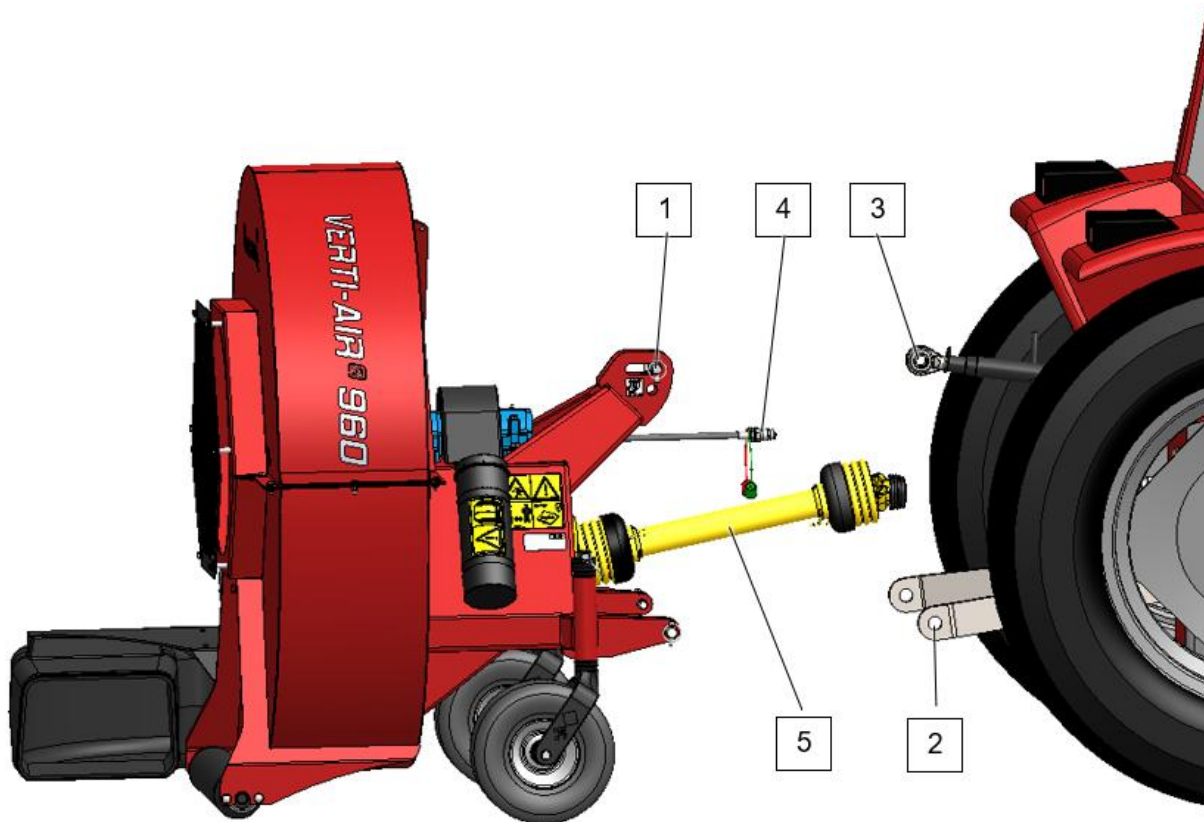

Fig. 6

7.1. Attaching the machine

Before attaching the machine, check the following points:

- Check if the machine is undamaged and if it is safe to attach and use.
- Check the fasteners for the correct fastening torque.
- Check if all safety stickers are on the machine, undamaged and easily readable.

The machine should be attached to the tractor in the following manner (Fig. 6):

1. Remove the top 3-point pin (1) from the machine.
2. Carefully drive the tractor backwards until the lifting arms (2) can be attached to the machine.



Make sure that the tractor and the machine cannot move while you are attaching them.



Switch OFF the tractor engine before attaching the machine.

3. Attach the lifting arms (2) to the machine using the 3-point pins. Lock the pins using the clips.

4. Set the stabilizer of the lifting arms (2) to 100 mm lateral stroke.
5. Mount the top rod (3) onto the tractor and attach it to the machine. Adjust the length of the top rod until the PTO-shaft of the machine is horizontal.



If the machine is not correctly mounted behind the tractor, different PTO angles can cause vibrations in the machine's drivetrain. These vibrations can damage the machine.

6. Connect the PTO (5) between the machine and the tractor (free-running clutch on machine side).
7. Connect the hydraulic hoses (4) to the tractor.



Make sure that the 3-point pins are locked using the clips.

8. Start the tractor and lift the machine.

7.2. Detaching the machine

The machine should be detached in the following manner: (Fig. 6)

1. Take the attached machine to the storage location.



Make sure the storage location has a stable level surface and can support the machine's weight.



Make sure that the tractor and machine cannot move uncontrolled.



Switch OFF the tractor's engine and PTO before getting off the tractor.

2. Place the machine gently onto the surface.



Check again if the surface can support the machine's weight.



3. Disconnect and remove the top rod (3).
4. Disconnect the lifting arms (2).
5. Disconnect the hydraulic hoses (4) from the tractor and store these.
6. Disconnect the PTO shaft (5) from the tractor.
7. Start the tractor and drive carefully away from the machine.

8. TRANSPORT

The user is responsible for transporting the machine on public roads. Make sure to comply with all applicable national transport regulations. In view of the machine's weight, it is not recommended to drive faster than 20 km/h (12.4 mph) with a raised machine. Higher speeds can lead to hazardous situations and result in damage to the machine and tractor.

 **When the machine is raised off the ground, the front shaft of the tractor must support minimum 20% of its weight.**

If the machine is not transported by tractor towing, it can be secured or lifted at the following points (Fig. 7):

	<p>Securing points are located near these stickers.</p>
	<p>Hoisting points are located near these stickers.</p>

- Points for securing the machine (4x) are positioned at both sides of the machine.
- Hoisting points (2x) for lifting the machine.

 **Keep a safe distance, the machine may turn or slide away during hoisting.**

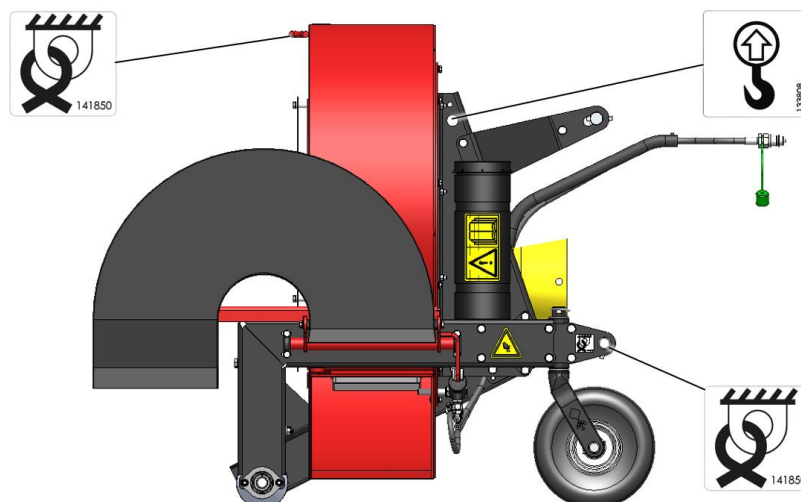

Fig. 7

9. PUTTING THE MACHINE INTO OPERATION

9.1. Safety

Before starting to use the machine, check the following:

- Are there any loose objects on the field, other than what this machine is intended for? Remove them first or keep a sufficient distance from them.
- Are there any persons within the danger zone of the machine? Postpone the work or ensure they keep a safe distance.



Check the compatibility of the drive system and vehicle at first use. Working at full PTO rpm in the wrong driving direction (CCW or CW) may cause damage to the rotor.



If the machine cannot be operated safely, postpone the work.

- Are there slopes? The maximum slope is 20 degrees for this machine. Always work from the top down.
- Make sure to always have the working area in sight.
- Are there firm objects above ground? If so, use the machine with adjusted speed and work around them or lift the machine.
- Is there danger of objects or distraction of the driver? If so, the machine CANNOT be used.
- Is there danger of sinking/sliding away or damaging the soil? If so, postpone the work.
- Do NOT make sharp turn when the machine is touching the ground.
- The Verti-Air® 960 may only be driven at a speed of 540 rpm. Higher speeds are not permitted. Carefully engage the PTO clutch at the lowest possible speed.
- The impeller has a certain inertia and is directly connected to the gearbox. To avoid overloading during start-up, engage the PTO carefully. Then, bring the impeller up to operating speed at a leisurely pace.

9.2. Running-in period

Your machine has been tested in the factory. The drive has been running at 540 rpm for at least 10 minutes, and the V-belts have been adjusted to the correct pre-tension. However, the V-belts still require inspection and adjustment during the running-in period. It is important not to overload the drive system on the first day of operation. The drive needs to “settle” further, especially the V-belts.

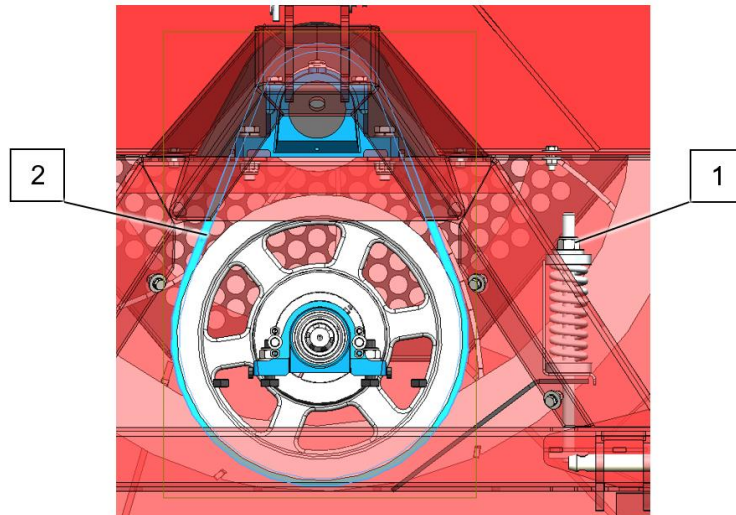

Fig. 8

Therefore, after the first day of operation, the V-belts should be readjusted as follows (Fig. 8):

1. Turn OFF the tractor and remove the key from the ignition. Remove the V-belt guard and check the V-belt tension at location **2**.
2. If necessary, adjust it with the adjustment bolt (1).
3. Check for loose bolts etc.
4. Refit the protective cover.

The procedure should be repeated according to the maintenance schedule (see Ch.11.1).

9.3. Working speed

The maximum working speed of the machine depends on the desired result, the situation of the environment and is limited to 12 km/h (7.5 mph). Higher speed is not recommended due to excessive wear and possible damage to the machine.



If the circumstances require, the working speed should be reduced.

9.4. Start/Stop procedure

The start procedure is very important. If this procedure is not executed as described below, it might result in serious damage to the machine.

The start procedure is as follows:

1. Inspect the machine for any loose components and ensure that all parts operate correctly.



If loose components are observed or components do not function properly, the problems must be solved before using the machine.



Always lower the machine carefully.

2. Drive to the location where the work should take place.
3. Slowly lower the machine to the ground.
4. Rotate the exhaust to the desired direction.
5. Adjust the tractor engine to around 1200 rpm.
6. Switch ON the PTO.
7. Put the tractor in the correct gears and drive forwards.
8. Increase the PTO's revolutions to the maximum allowed value of 540 RPM or until the material is properly removed.



**Watch out for thrown material at all times. It can cause damage or injury.
Reduce the PTO speed, if necessary.**

9. Check the result and adjust the RPM and driving speed, if necessary.

The stop procedure is as follows:

1. Reduce the PTO rpm.
2. Disengage the PTO and lift the machine, if necessary.
3. The impeller continues to run freely after the PTO is switched off.



Do not re-engage the PTO until the rotor has completely stopped rotating.

4. Go to the next location and start again, as described.

10. TECHNICAL INFORMATION

Generally, the Verti-Air® 960 is not a complicated machine. A number of technical items will be explained below. If you have further questions regarding this machine, please contact your dealer.

10.1. Hydraulic control reverse spout

By using the hydraulic connection (1), the position of the reverse spout (2) can be defined (Fig. 9). As a result, air is blown out to the left, right, or both sides of the machine.

By using the restrictor valve (3), the speed of the hydraulic control can be regulated.

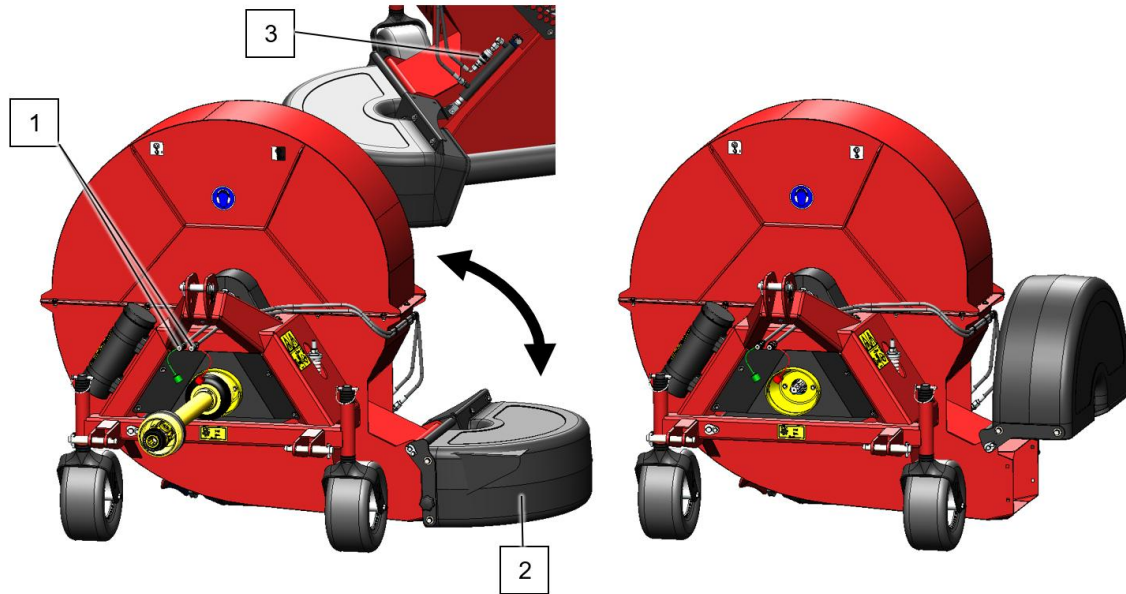

Fig. 9



Beware of constriction of body parts. Keep a safe distance.

10.2. Outlet flap

Instead of the reverse spout, the supplied outlet flap can also be used (1). Unlike the reverse spout, airflow is now only possible on one side of the machine. However, the airflow in the vertical plane can be regulated by adjusting the outlet flap (Fig. 10).

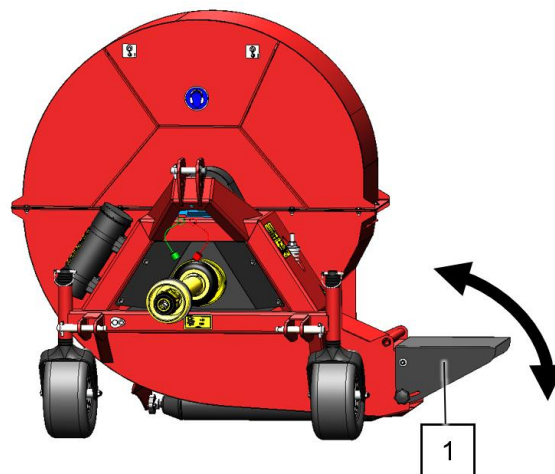

Fig. 10

11. MAINTENANCE

11.1. Maintenance schedule

Time schedule	Check point	Work activities
Before every use	Check for loose parts, bolts and nuts.	Tighten the loose bolts / nuts properly.
	General check	Attach the machine to the tractor and let it run for 5 minutes. Watch and listen for any unusual movements or noises.
	Safety stickers	Presence and readability of the safety stickers. Replace these if not present or damaged.
	Loose hanging parts around the PTO	Tighten the parts so that they cannot reach the PTO.
After the first 20 working hours (new or repaired)	Lubricate the PTO bearings.	Use 2 shots of Ceran XM 220 grease. See Ch.11.4 for the positioning of the grease points.
	Check the tension of the V-belts.	If needed, re-tighten the V-belts, as described in Ch.11.2.
	Check for loose parts, bolts and nuts.	Tighten loose bolts / nuts properly.
	General check	Attach the machine to the tractor and operate the machine for 5 minutes. Watch and listen for any unusual movements or noises.
	Loose hanging parts around the PTO	Tighten the parts so that they cannot reach the PTO.
After every 50 working hours	Lubricate the PTO bearings.	Use 2 shots of Ceran XM 220 grease. See Ch.11.4 for the positioning of the grease points.
	Check for loose parts, bolts and nuts.	Tighten loose bolts / nuts properly.
	Check the tension of the V-belts.	If needed, re-tighten the V-belts as described in Ch.11.2.
	Check tire pressure.	Check tire pressure and top up to a maximum of 1.9 bar.
	General check	Attach the machine to the tractor and let it run for 5 minutes. Watch and listen for any unusual movements or noises.
After every 500 working hours or every year	General check	Attach the machine to the tractor and let it run for 5 minutes. Watch and listen for any unusual movements or noises.
	Check the tension of the V-belts.	If needed, re-tighten the V-belts as described in Ch.11.2.

11.2. V-belt tension

Correct pre-tensioning of the V-belts is very important for proper functioning and a long service life.

The correct tension is achieved when you can press the belts in by approximately 8 mm (0.32") (2) halfway between the two pulleys (see above Fig. 8). Ensure that the V-belts remain clean and dry.

With a compression of 8 mm (0.32"), maintain the following tensions:

- Compression tension of new V-belt 4.8 kg (10.8 lbs)
- Normal compression tension 3.2 kg (7 lbs)
- If compression tension falls below 2.6 kg (5.7 lbs) tighten V-belt to 3.4 kg (7.5 lbs)



Always replace all V-belts at the same time.



It is advisable to slightly reduce the V-belt tension if the machine will remain unused for an extended period. To do this, loosen the adjustment bolt (1) a few turns (see above Fig. 8).

11.3. Cleaning

If a high-pressure cleaner is used to clean the machine, then observe the following rules:

- Do not use aggressive cleaning agents that can affect the machine.
- Maximum water pressure: 70 Bar (1015 PSI)
- Maximum water temperature: 50°C (122°F)
- Do not aim the jet of the high-pressure nozzle directly at the bearings, oil seals, lubrication points, and stickers.
- Keep a minimum distance of 0.5 m (1.6 ft) between the head of the high-pressure cleaner and the surface you want to clean.



Grease the bearing points after cleaning the machine.

11.4. Lubrication points

To ensure proper machine operation, the lubrication points on either side of the PTO should be lubricated periodically (Fig. 11). Lubricate the points according to the maintenance schedule (see Ch.11.1).

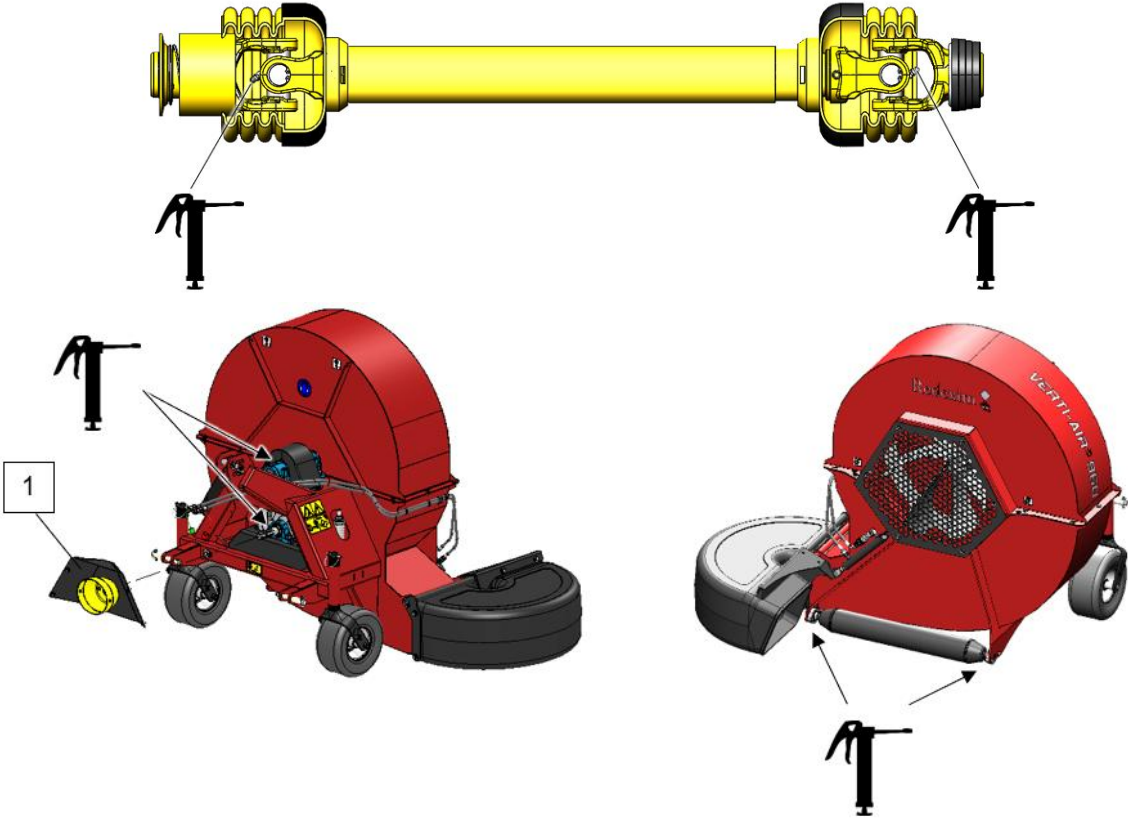

Fig. 11

12. TROUBLE SHOOTING

Problem	Possible cause	Solution
Machine vibrates.	<ul style="list-style-type: none"> - PTO shafts do not align. - Wear and tear. - V-belts have a tough spot after a long stand still. 	<ul style="list-style-type: none"> - Change the length of the toplink until the shafts align. - Check the drive system and rotor. - Let the machine run for a longer period. - Replace V-belts.
Material does not get blown away.	<ul style="list-style-type: none"> - Inlet is blocked. - Exhaust is blocked. - Drive rotation is wrong. - Exhaust is facing the wrong way. 	<ul style="list-style-type: none"> - Remove material from the inlet mesh. - Reposition the exhaust flap. - Check the rotation direction of the tractor and the machine. - Change the position of the exhaust.
Machine makes noises.	<ul style="list-style-type: none"> - Drive rotation is wrong. - V-belts slip. - Wear and tear - Loose parts on machine 	<ul style="list-style-type: none"> - Check direction of rotation of tractor and machine. - Check tension and V-belt quality and act accordingly. - Check machine for non-fixed items.
Oil leakage	<ul style="list-style-type: none"> - Hydraulics are leaking. 	<ul style="list-style-type: none"> - Check the hydraulic system.