

LASER-GRADER 1500



Version: 2537



Kwekerijweg 8 | 3709JA | Zeist | The Netherlands |
T: +31 (0)306 933 227
E: redexim@redexim.com
W: www.redexim.com

Grader 1500

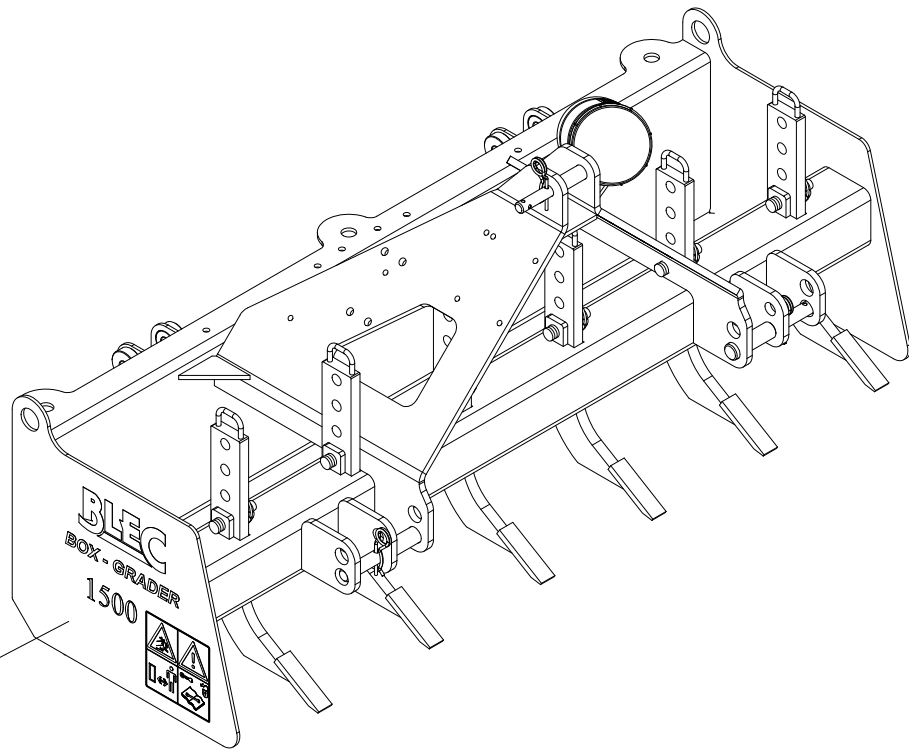
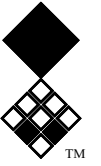

Page 02

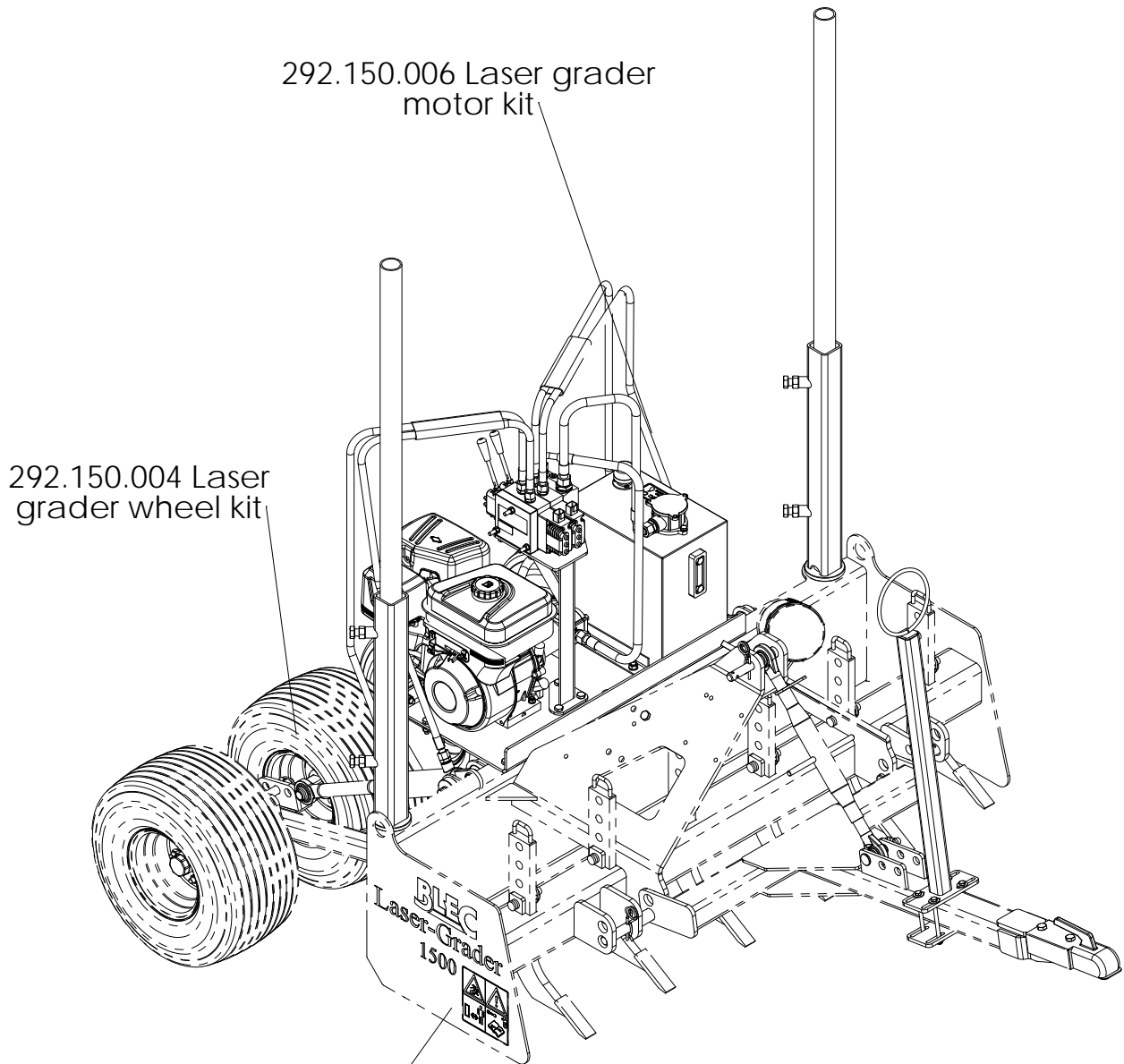

Page 03 - 10

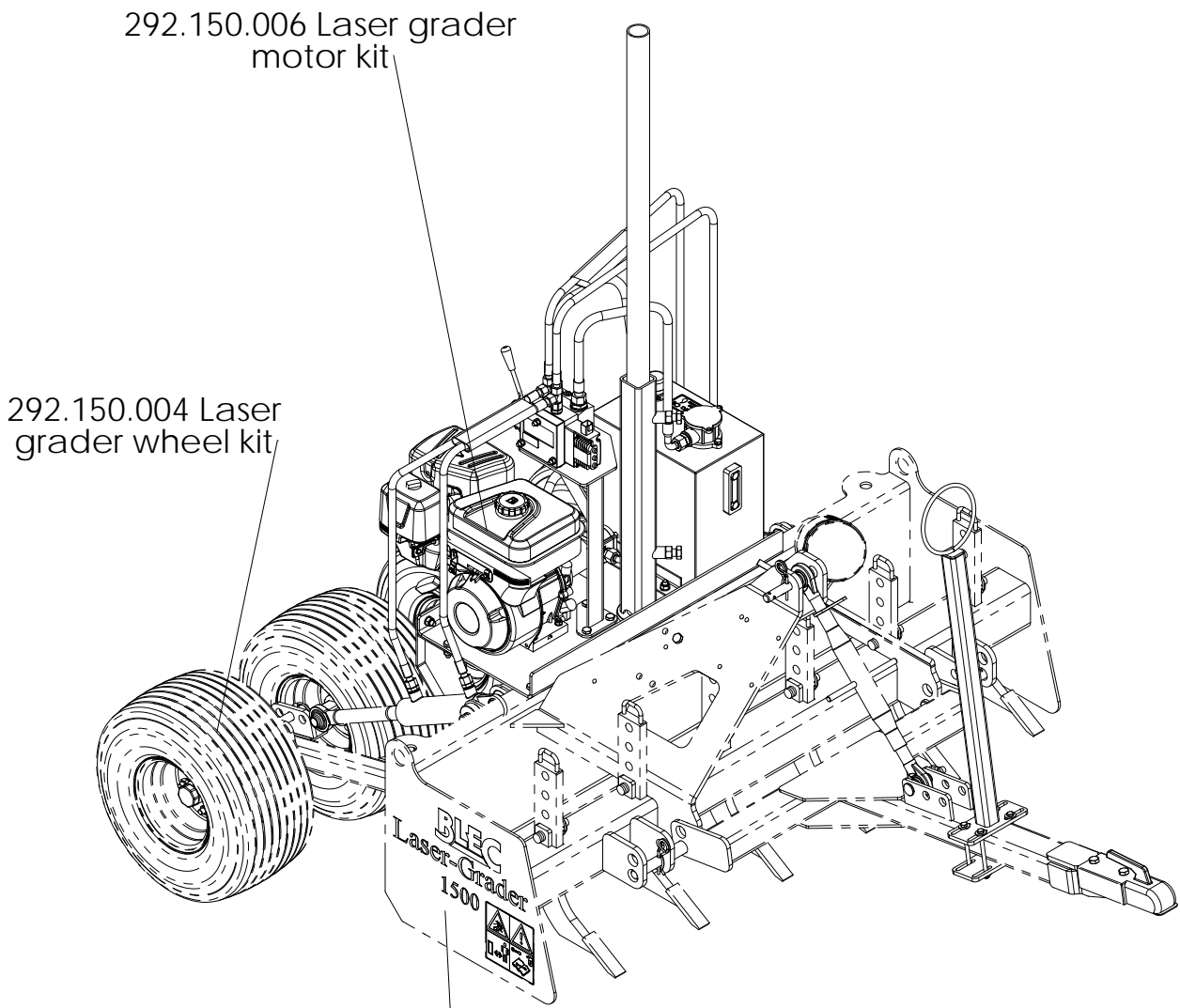
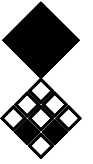

Page 11 - 12

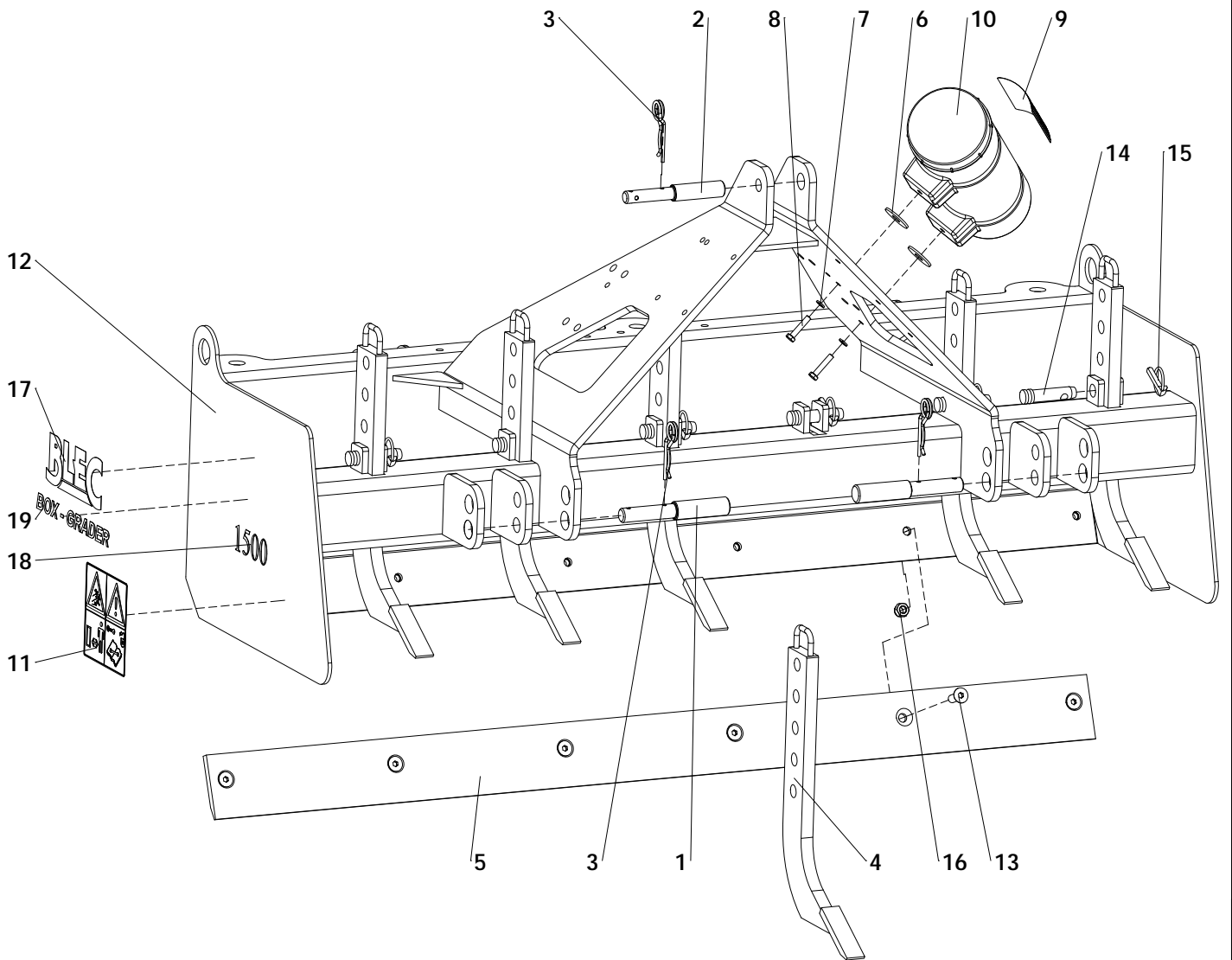
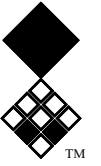

ITEM	PART NUMBER	DESCRIPTION	REMARKS	QUA
1	521.221.600	3-point pin		2
2	521.191.600	Top link pin OS		1
3	523.051.000	R-clip Round 5, DIN 11024		3
4	391.720.484	Ripping tine		6
5	468.129.150	Blade		1
6	864.140.031	Large washer M14 - DIN 9021		2
7	866.080.020	Spring Washer M8 - DIN 127		2
8	804.080.400	Bolt M8 x 40 - ISO 4017		2
9	900.280.402	Safety decall manual		1
10	444.803.100	Toolbox Complete		1
11	933.280.402	Safety decall		2
12	494.151.062	Frame Laser-Grader 1500		1
13	816.120.350	Bolt M12 x 35- DIN 7991		6
14	521.190.730	Top link pin D19 L = 46		6
15	523.100.570	Linch Pin d10		6
16	830.120.120	Self Lock Nut M12 - ISO 10511		6
17	900.260.504	Decall Blec black		2
18	913.260.417	Label 1500 black		2
19	992.260.504	Label Box-Grader		2
	192.150.000	Box-Grader 1500 assembly	Complete Box-Grader 1500	

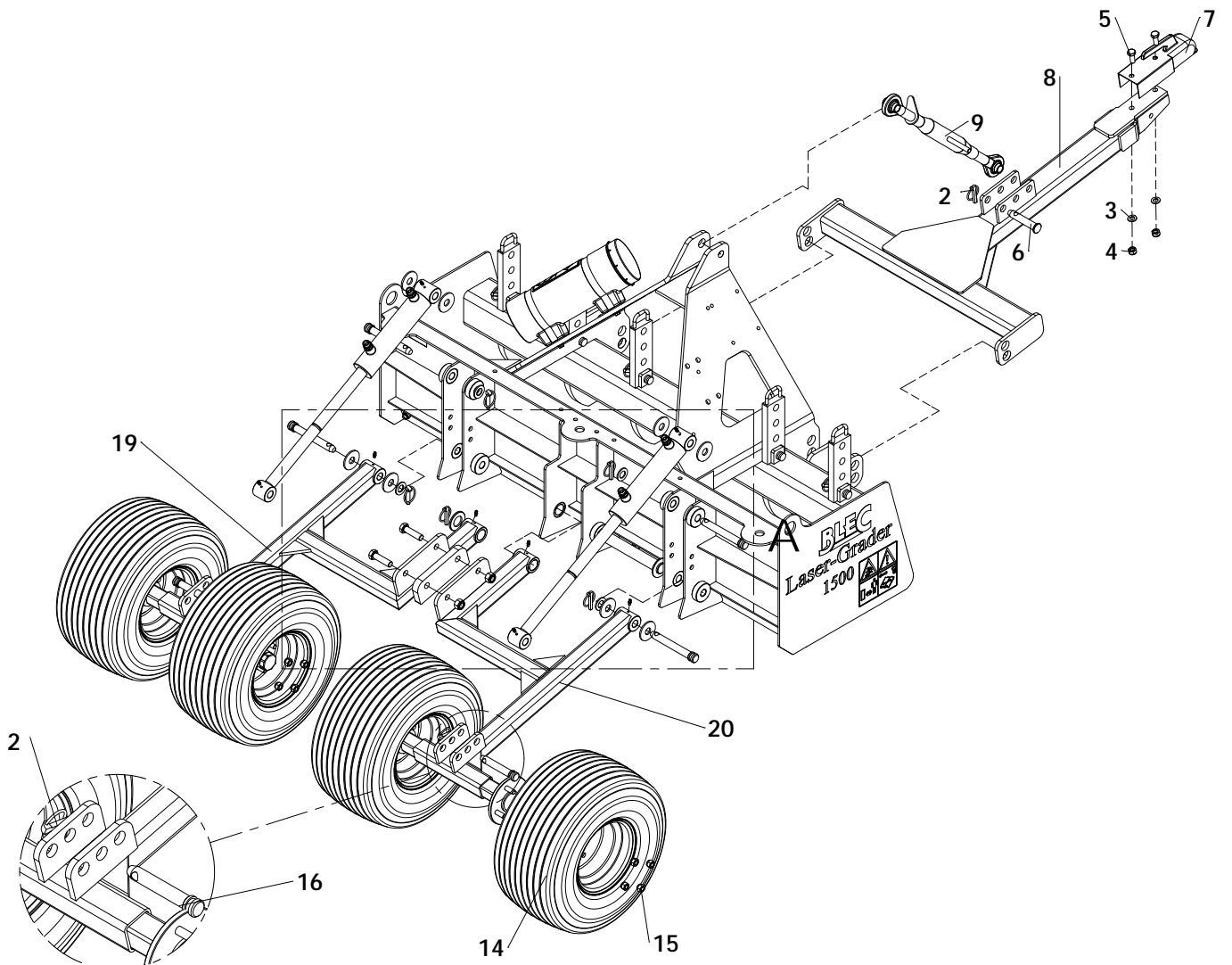
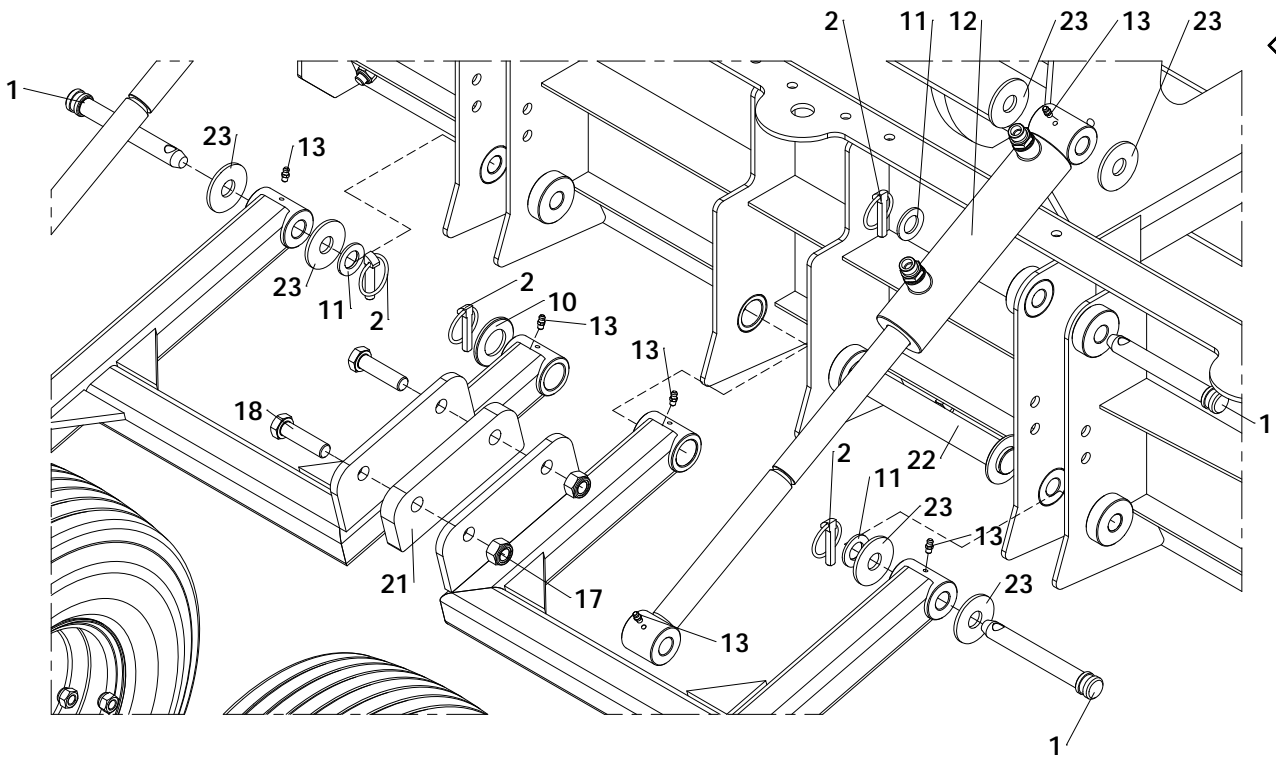
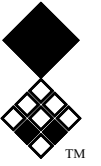

ITEM	PART NUMBER	DESCRIPTION	REMARKS	QUA
1	521.191.270	Top Link Pin		4
2	523.100.570	Linch Pin d10		8
3	864.120.030	Washer M12 - ISO 7089		2
4	830.120.120	Self Lock Nut M12 - ISO 10511		2
5	804.120.300	Bolt M12 x 30 - ISO 4017		2
6	521.190.740	Top Link Pin Ø19 L=74		1
7	529.701.500	Coupling 1500KG VK70		1
8	494.078.100	Drawbar		1
9	522.194.450	Toplink Cat. 1 L0=498 Stroke=200		1
10	864.300.055	Washer M30 - ISO 7089		1
11	864.200.030	Washer M20 - ISO 7089		4
12	534.300.581	Hydraulic cylinder 30-50, stroke 150mm		2
13	880.060.100	Grease nipple M6 DIN 71412A		8
14	511.542.234	Wheel Complete		4
15	844.120.120	Wheel nut M12x1.5		16
16	521.191.120	Top Link Pin		2
17	830.160.160	Self Lock Nut M16 - ISO 10511		2
18	802.160.600	Bolt M16 x 60 - ISO 4014		2
19	494.068.077	Wheel frame left		1
20	494.068.078	Wheel frame right		1
21	468.201.900	Spacer		1
22	474.302.200	Pivot pin		1
23	864.200.041	Large washer M20 - DIN 9021		8

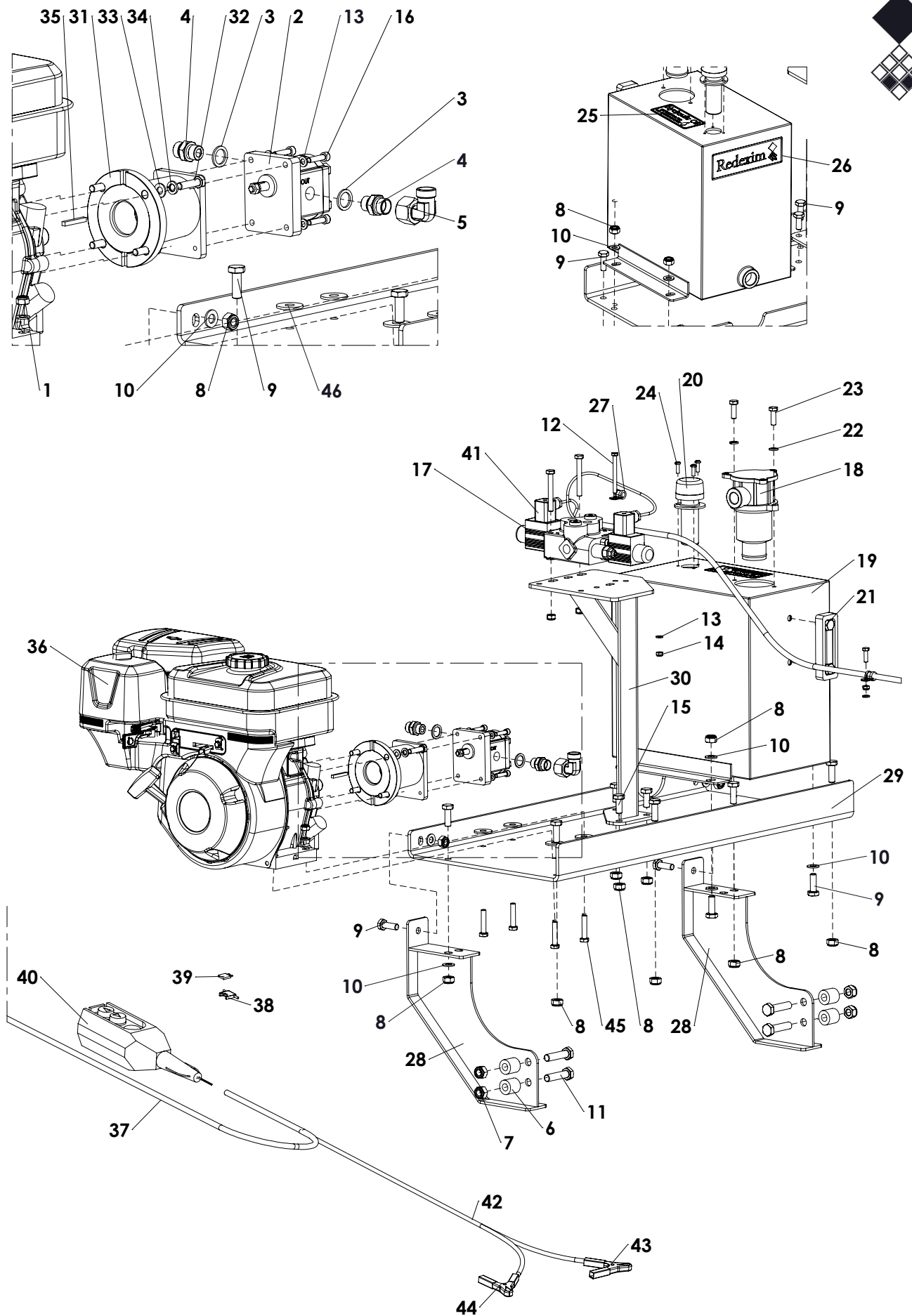

ITEM	PART NUMBER	DESCRIPTION	REMARKS	QUA
1	830.080.080	SL nut M8 - DIN 985 - Grade 8		4
2	531.091.050	Hydraulic pump PLP10 4.27		1
	531.091.051	Hydraulic pump HYDAC	PGE101-500-RBQ1-N-3700	
3	874.170.020	Bonded seal ring 3_8"		2
4	544.170.150	Nipple BSP 3_8" x pipe 15 (M22)		2
5	544.151.150	L-Connector PM. Pipe 15-M22		1
6	406.130.252	Distance bush Ø25/Ø12.5 L=25		4
7	830.120.120	SL nut M12 - DIN 985 - Grade 10		4
8	830.100.100	SL nut M10 - DIN 985 - Grade 10		14
9	804.100.300	Hex bolt M10 x 30 - ISO 4017 - Grade 8.8		11
10	864.100.030	Washer M10 - DIN 125A		11
11	802.120.500	Hex bolt M12 x 50 - ISO 4014 - Grade 10.9		4
12	802.060.650	Hex bolt M6 x 65 - ISO 4014 - Grade 8.8		1
13	864.060.030	Washer M6 - DIN 125A		5
14	830.060.060	SL nut M6 - DIN 985 - Grade 8		1
15	804.100.250	Hex bolt M10 x 25 - ISO 4017 - Grade 8.8		3
16	814.060.250	Hex HC screw M6 x 25 - DIN 912 - Grade 8.8	(only for Hydraulic pump PLP10 4.27)	4
	814.060.350	Hex HC screw M6 x 35 - DIN 912 - Grade 8.8	(only for Hydraulic pump HYDAC)	4
17	535.692.930	Valve SD51001 complete		1
18	533.601.440	Oil filter set		1
19	458.329.285	Oil tank		1
20	533.291.100	Filler cap		1
21	533.381.100	Oil level monitor		1
22	866.080.020	Spring washer M8 - DIN 127		2
23	804.080.250	Hex bolt M8 x 25 - ISO 4017 - Grade 8.8		2
24	824.050.160	SPH screw M5 x 16 - DIN 1580		3
25	911.340.406	Decall oil tank		1
26	900.260.401	Logo Label		1
27	547.080.160	Hose Clamp Ø8		1
28	470.042.740	Support		2
29	468.067.500	Tray LG TTP		1
30	470.053.910	Hydraulic tripod		1
31	678.191.100	Hydraulic adapter group 1 - 3/4"	Complete with coupling	1
32	808.080.320	Hex bolt 5/16" x 1-1/4" - UNF - ANSI B18.2.1 - Grade 5.2 (8.8)		4
33	864.080.030	Washer M8 - DIN 125A		4
34	866.080.020	Spring washer M8 - DIN 127		4
35	884.040.360	Key 3/16"x3/16" L=36mm		1
36	672.290.376	Briggs & Stratton 6.5 Hp 3/4 inch axle		1
37	563.089.400	Cable for valve L=4000		1
38	565.070.300	Fuse holder		1
39	565.050.208	Fuse 10A		1
40	569.672.830	Electric control unit		1
41	568.270.480	Cable plug		2
42	563.082.570	Feeding cable 1.5mm ² 2 wires L=2750		1
43	568.110.802	Battery clamp -		1
44	568.110.800	Battery clamp +		1
45	802.080.400	Hex bolt M8 x 40 - ISO 4014 - Grade 8.8		4
46	864.100.031	Washer M10 large - DIN 9021		4

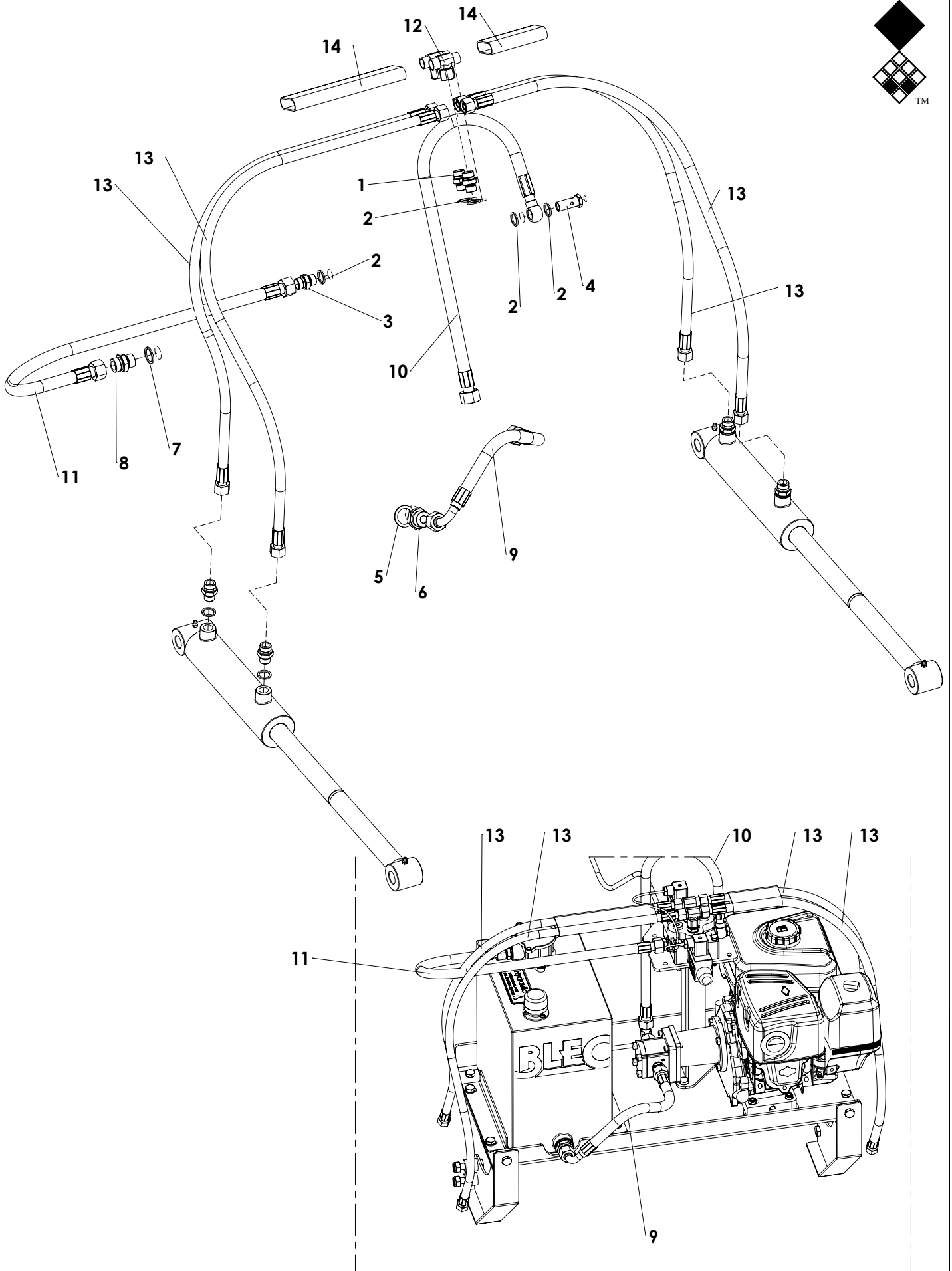
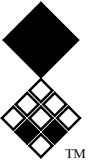

ITEM	PART NUMBER	DESCRIPTION	REMARKS	QUA
1	544.170.120	Nipple BSP 3_8" x pipe 12 (M18)		2
2	874.170.020	Copper washer 3_8		5
3	544.170.150	Nipple BSP 3_8" x pipe 15 (M22)		1
4	544.172.400	Cavity Bolt 3/8"		1
5	874.260.020	Copper washer 3/4"		1
6	544.460.300	Nipple BSP 3_4"x pipe 15 (M22)		1
7	874.210.020	Copper washer 1_2		1
8	544.210.150	Nipple BSP 1_2" x pipe 15 (M22)		1
9	541.190.350	Hose NSK13-1/2" TL=350 PGLO132290 + PGLO1322		1
10	541.190.600	Hose NSK13-1/2" TL=600 PGLO1322 + PQB136		1
11	541.190.800	Hose NSK13-1/2" TL=800 PGLO1322 + PGLO132290		1
12	544.124.126	T_-Connector PM, Pipe 12-M18		2
13	541.171.000	Hose NSK10-3/8" TL=1000 2xPGLO1018		4
14	549.014.000	Hose binder L=400		2

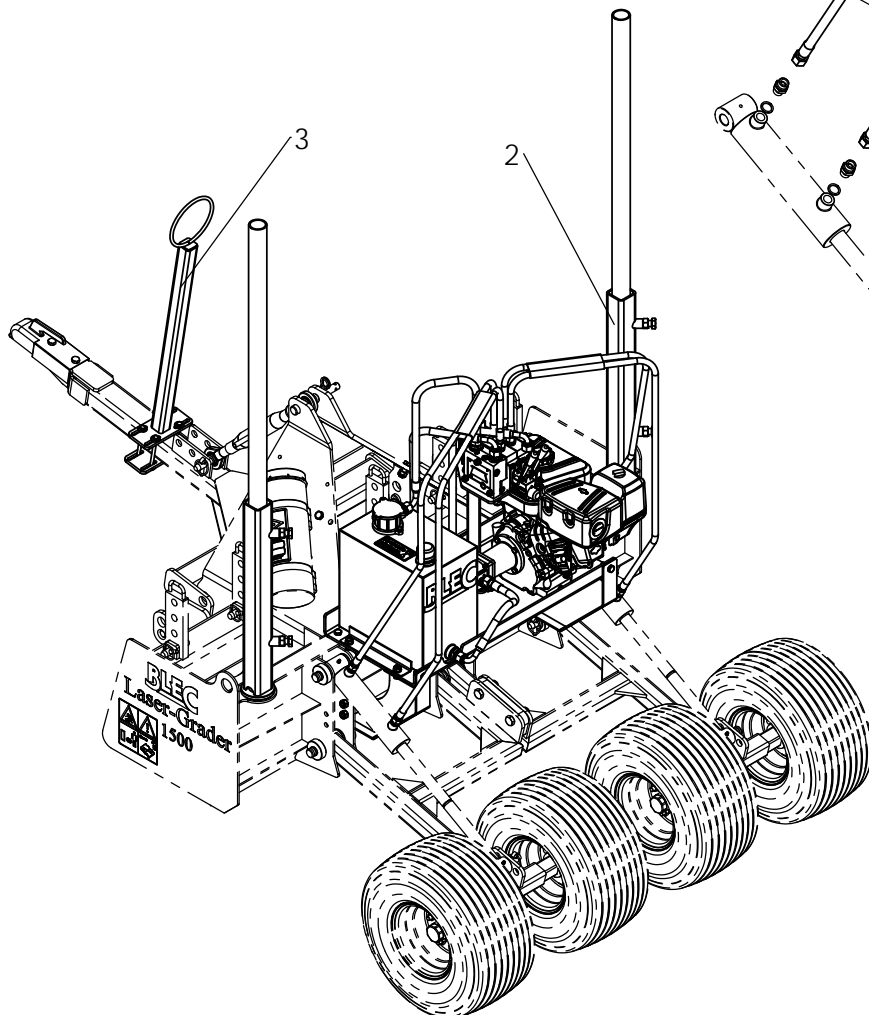
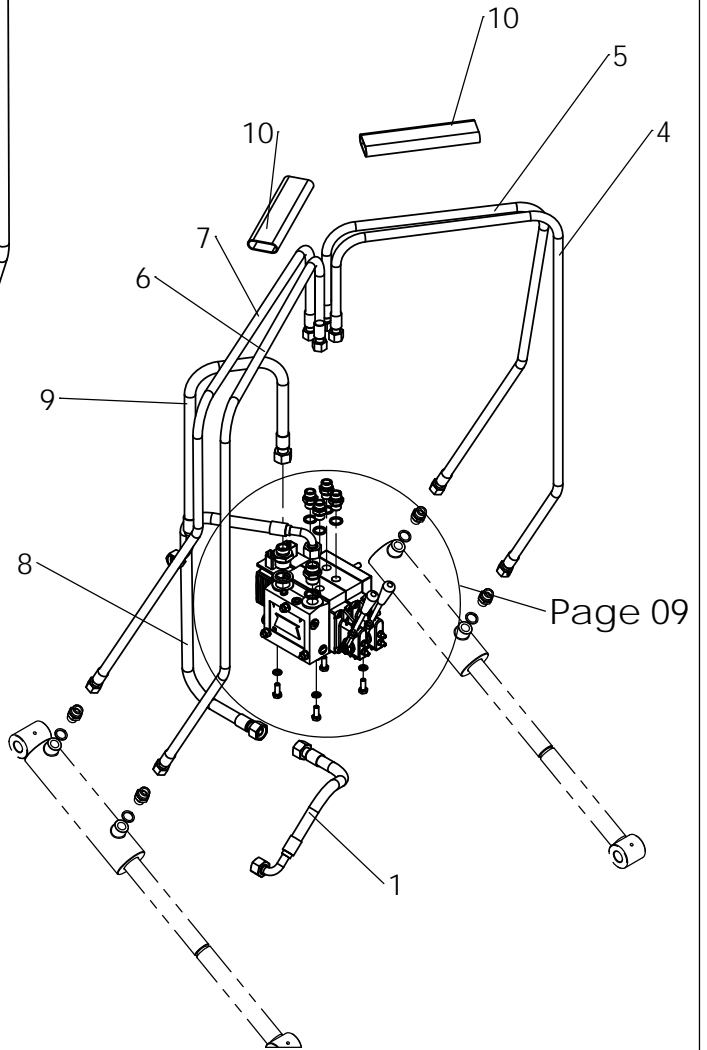
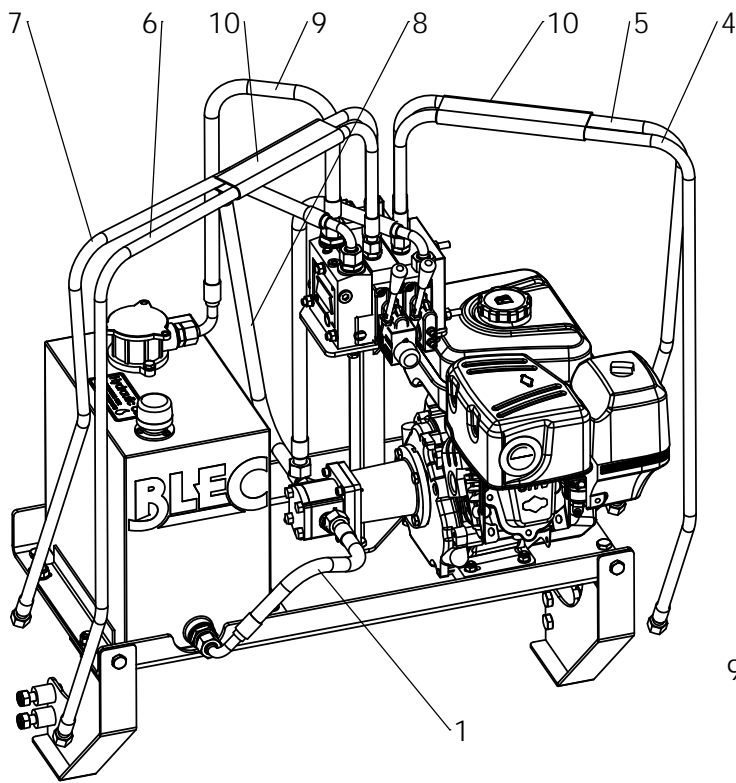

ITEM	PART NUMBER	DESCRIPTION	REMARKS	QUA
1	541.190.350	Hose NSK13-1/2" TL=350 PGLO132290 + PGLO1322		1
2	292.240.002	Laser pole assembly		2
3	292.180.010	Hose pole		1
4	541.171.254	Hose NSK10-3/8" TL=1250 2xPGLO1018		1
5	541.171.254	Hose NSK10-3/8" TL=1250 2xPGLO1018		1
6	541.171.254	Hose NSK10-3/8" TL=1250 2xPGLO1018		1
7	541.171.254	Hose NSK10-3/8" TL=1250 2xPGLO1018		1
8	541.190.800	Hose NSK13-1/2" TL=800 PGLO1322 PGLO132290		1
9	541.190.800	Hose NSK13-1/2" TL=800 PGLO1322 PGLO132290		1
10	549.014.000	Hose binder L=400		2

Optional valve dual laser for motor kit

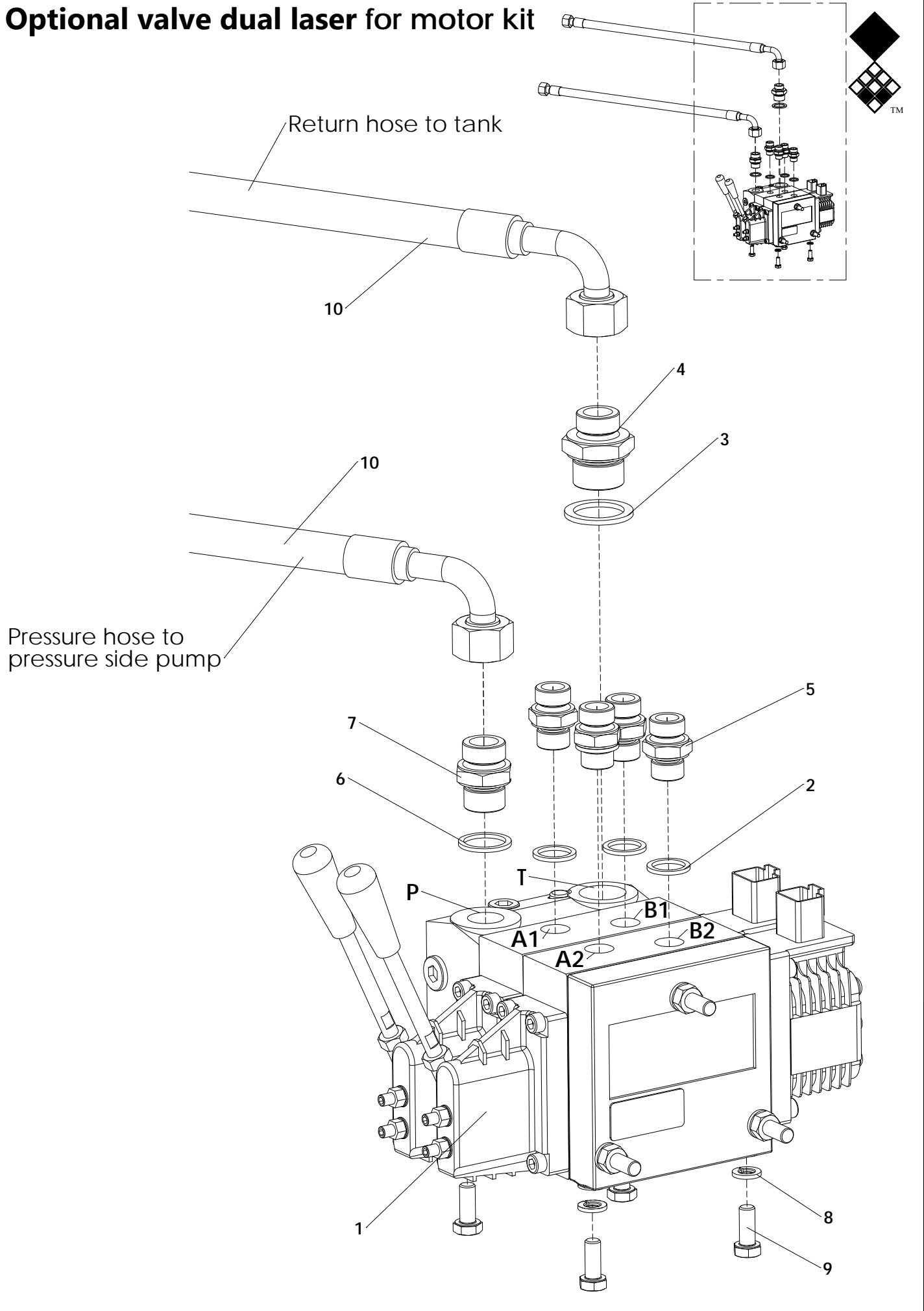

ITEM	PART NUMBER	DESCRIPTION	REMARKS	QUA
1	535.110.166	PVG16 Valve 2 sections		1
2	874.170.020	Copper washer 3_8		4
3	874.260.020	Copper washer 3/4"		1
4	544.260.222	Nipple pipe 3_4"x pipe 15 (M22)		1
5	544.170.120	Nipple BSP 3_8" x pipe 12 (M18)		4
6	874.210.020	Copper washer 1_2		1
7	544.210.150	Nipple BSP 1_2" x pipe 15 (M22)		1
8	866.080.020	Spring Washer M8 - DIN 127		4
9	804.080.200	Bolt M8 x 20 - ISO 4017		4
10	541.190.800	Hose NSK13-1/2" TL=800 PGLO1322 PGLO132290		2

Hydraulic diagram PVG to motor

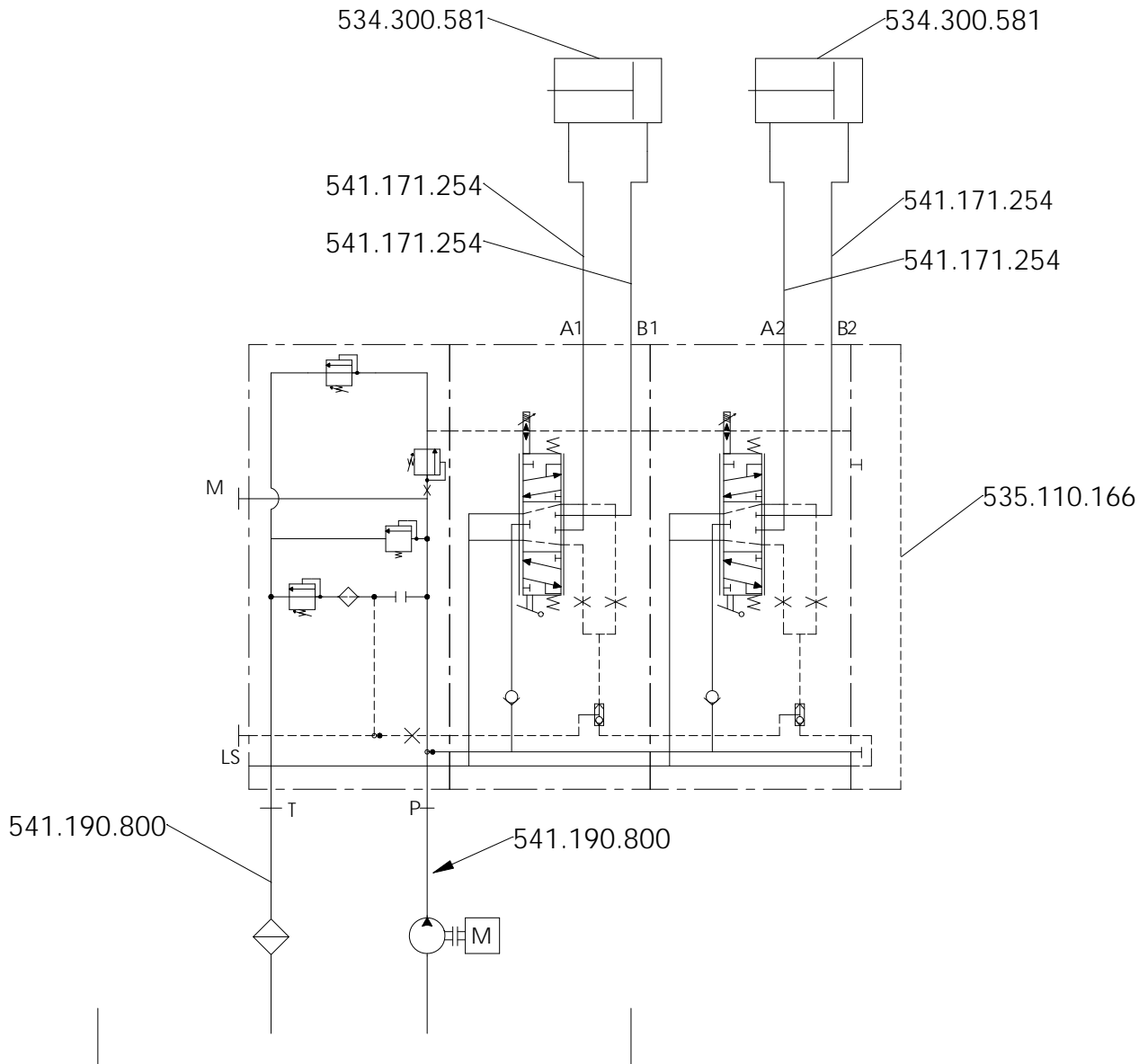

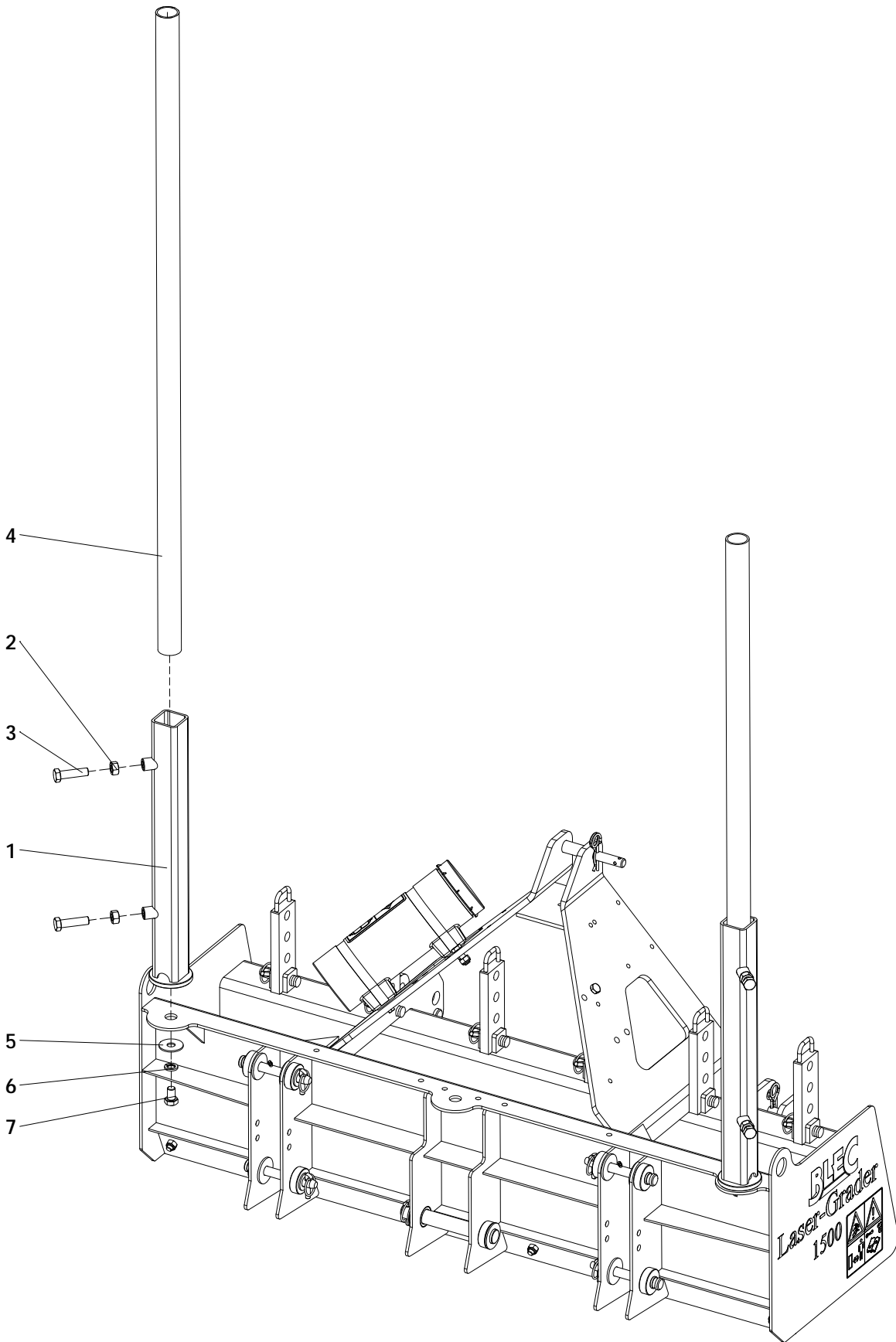
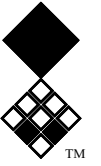

ITEM	PART NUMBER	DESCRIPTION	REMARKS	QUA
1	462.906.160	Pole base		1
2	826.160.160	Nut M16 - DIN 934		2
3	804.160.600	Bolt M16 x 60 - ISO 4017		2
4	476.489.150	Pole		1
5	864.160.031	Large washer M16 - DIN 9021		1
6	866.160.020	Spring Washer M16 - DIN 127		1
7	804.160.250	Bolt M16 x 25 - ISO 4017		1
	292.240.002	Laser pole assembly	Kit numer for 1 pole	

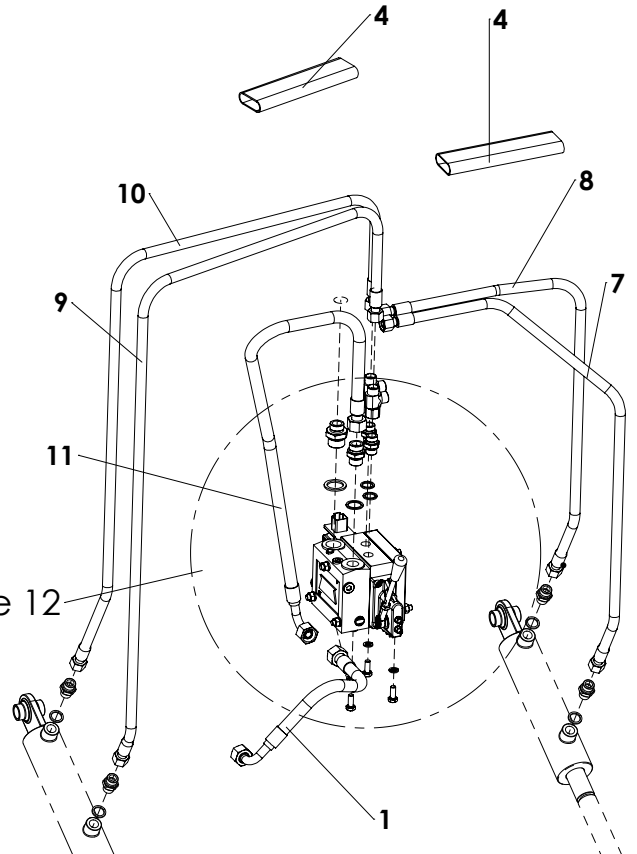
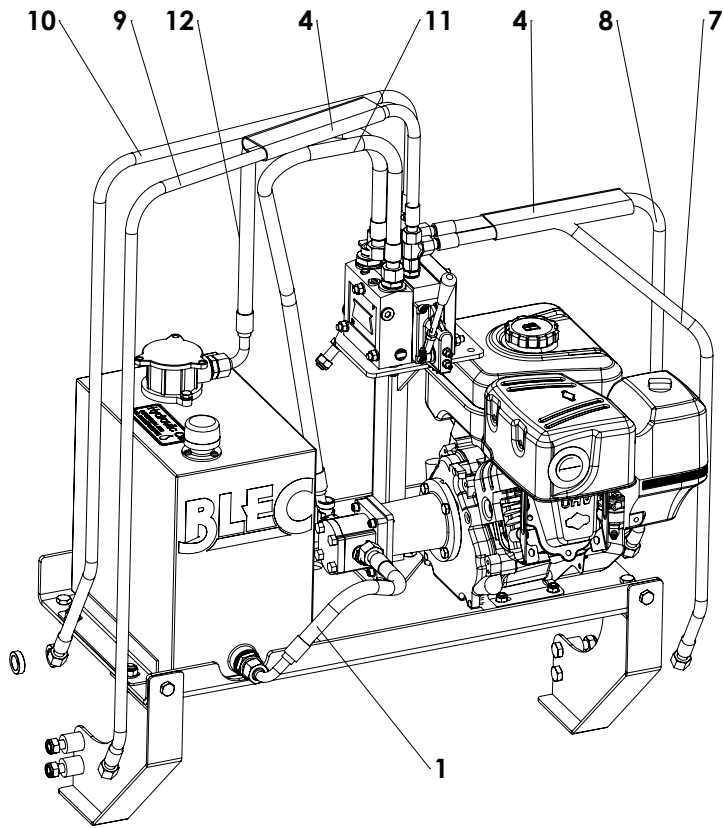

Page 12

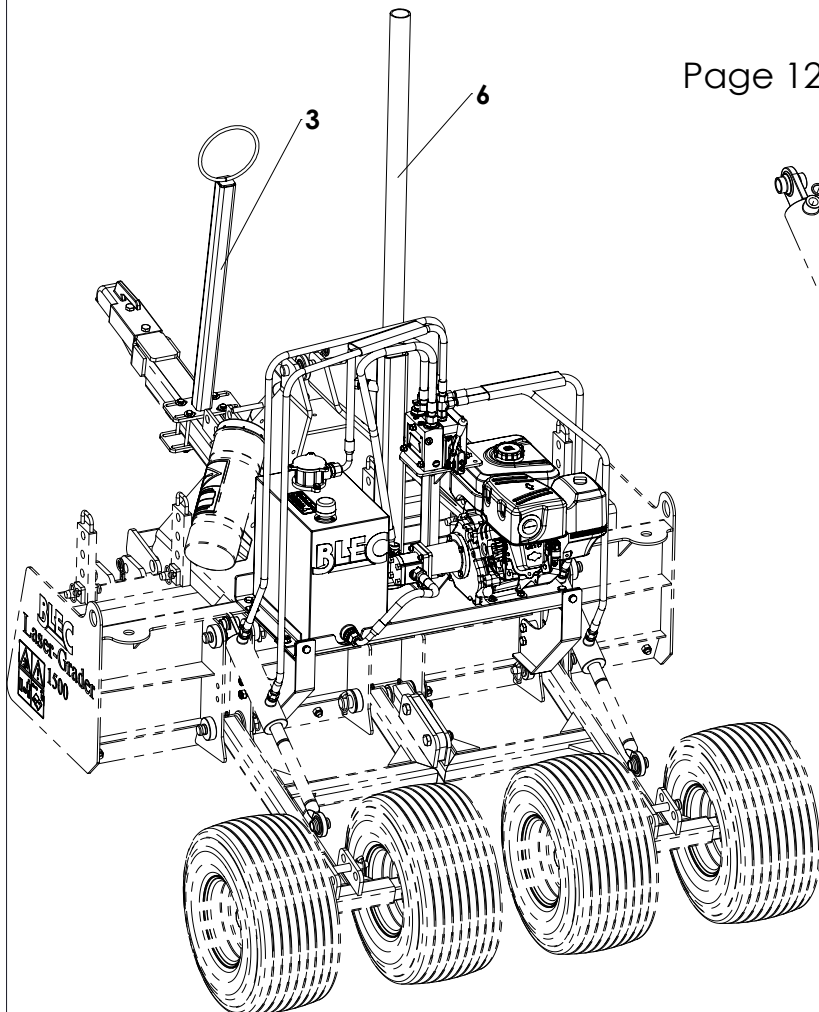

ITEM	PART NUMBER	DESCRIPTION	REMARKS	QUA
1	541.190.350	Hose NSK13-1/2" TL=350 PGLO132290 + PGLO1322		1
2	402.190.085	Distance bush		4
3	292.180.010	Hose pole		1
4	549.014.000	Hose binder L=400		2
5	535.110.165	PVG16 Valve 1 section		1
6	292.240.002	Laser pole assembly		1
7	541.171.254	Hose NSK10-3/8" TL=1250 2xPGLO1018		1
8	541.171.254	Hose NSK10-3/8" TL=1250 2xPGLO1018		1
9	541.171.254	Hose NSK10-3/8" TL=1250 2xPGLO1018		1
10	541.171.254	Hose NSK10-3/8" TL=1250 2xPGLO1018		1
11	541.190.800	Hose NSK13-1/2" TL=800 PGLO1322 + PGLO132290		1
12	541.190.800	Hose NSK13-1/2" TL=800 PGLO1322 + PGLO132290		1

Optional valve single laser for motor kit

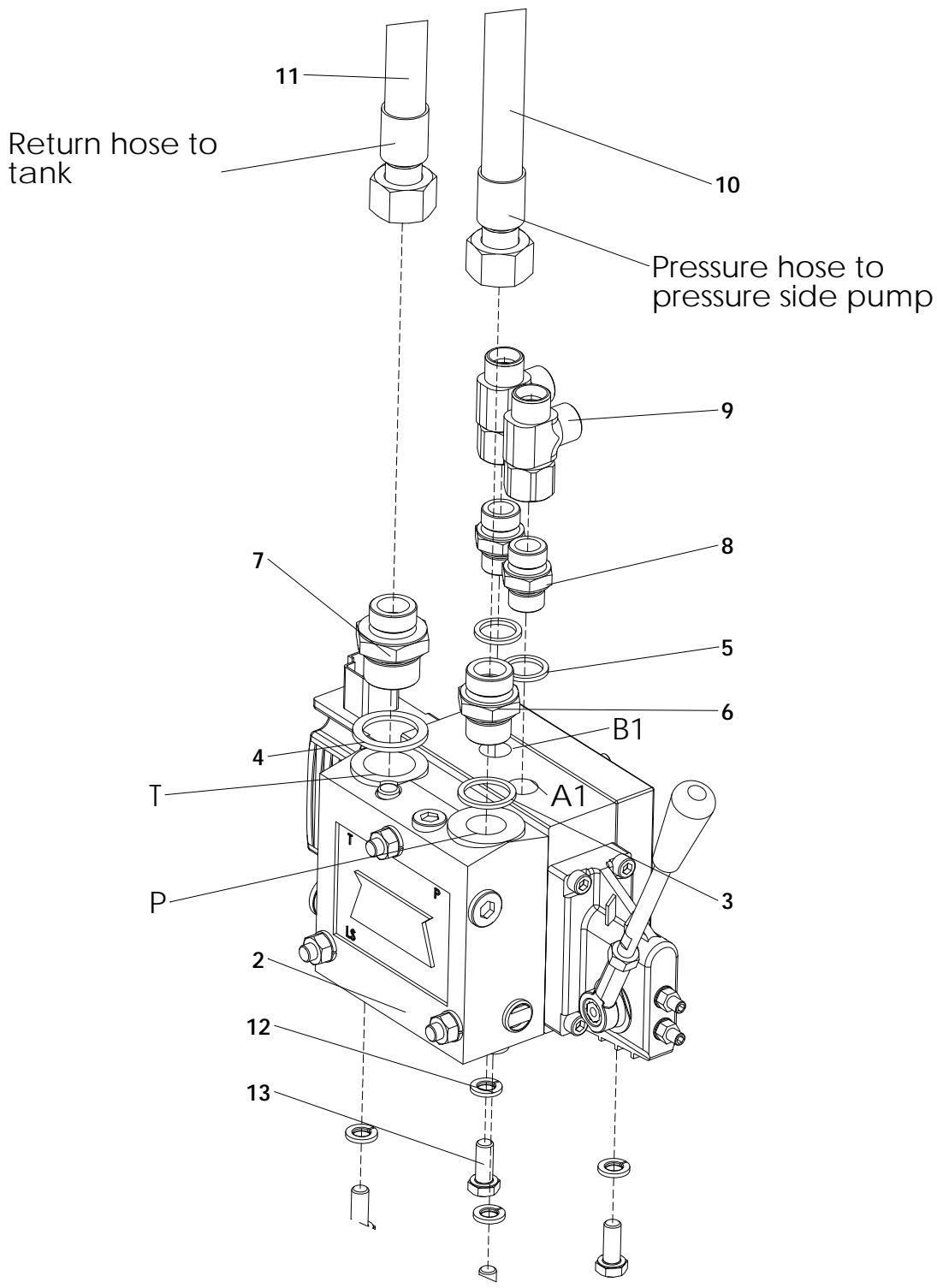
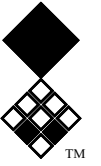

ITEM	PART NUMBER	DESCRIPTION	REMARKS	QUA
1	402.190.085	Distance bush		4
2	535.110.165	PVG16 Valve 1 section		1
3	874.210.020	Copper washer 1_2		1
4	874.260.020	Copper washer 3/4"		1
5	874.170.020	Copper washer 3_8		2
6	544.210.150	Nipple BSP 1_2" x pipe 15 (M22)		1
7	544.460.300	Nipple BSP 3_4"x pipe 15 (M22)		1
8	544.170.120	Nipple BSP 3_8" x pipe 12 (M18)		2
9	544.124.600	T_Connector PM, Pipe 12-M18		2
10	541.190.800	Hose NSK13-1/2" TL=800 PGLO1322 + PGLO132290		1
11	541.190.800	Hose NSK13-1/2" TL=800 PGLO1322 + PGLO132290		1
12	866.080.020	Spring Washer M8 - DIN 127		4
13	804.080.200	Bolt M8 x 20 - ISO 4017		4

Hydraulic diagram PVG to motor

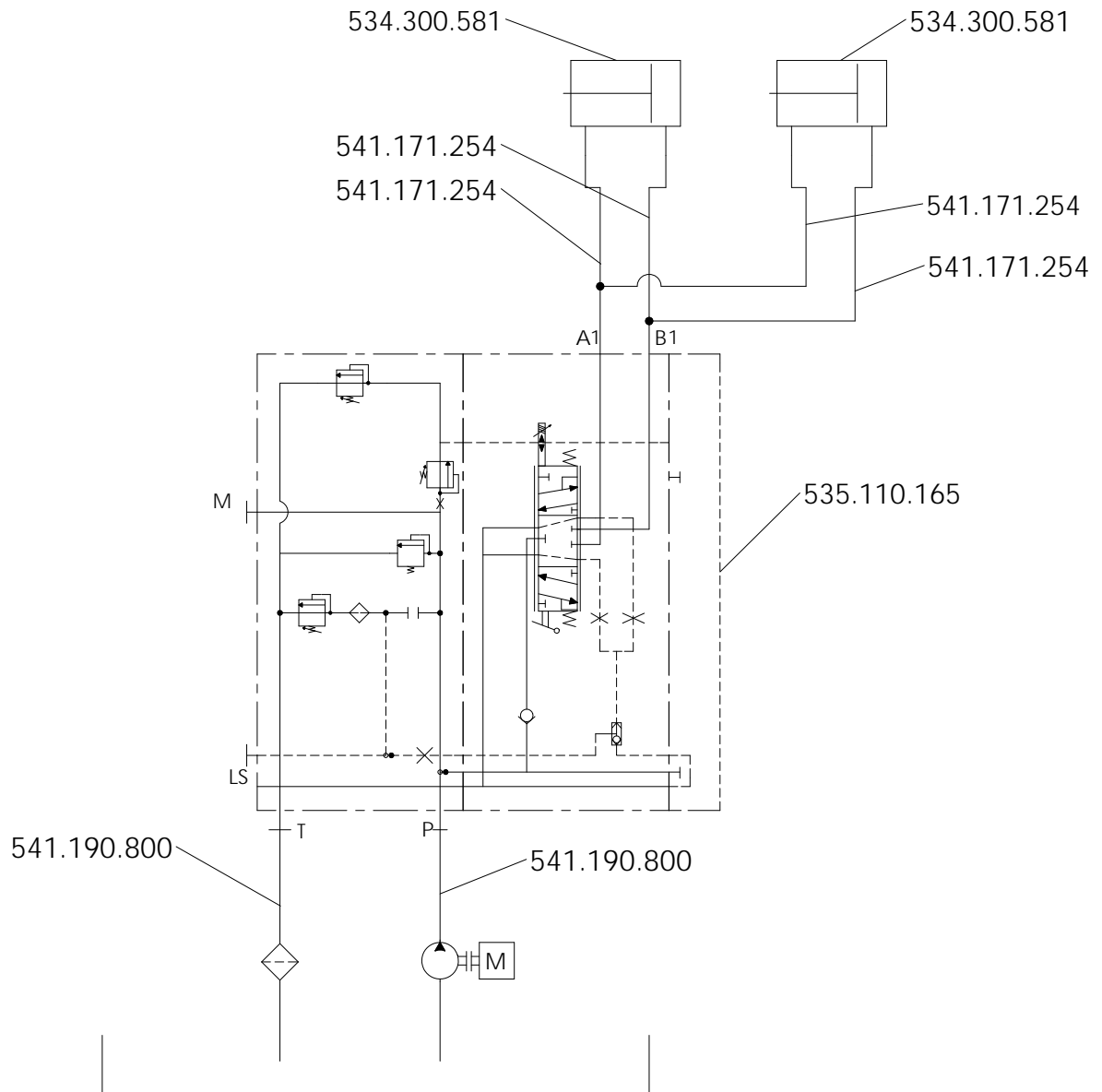

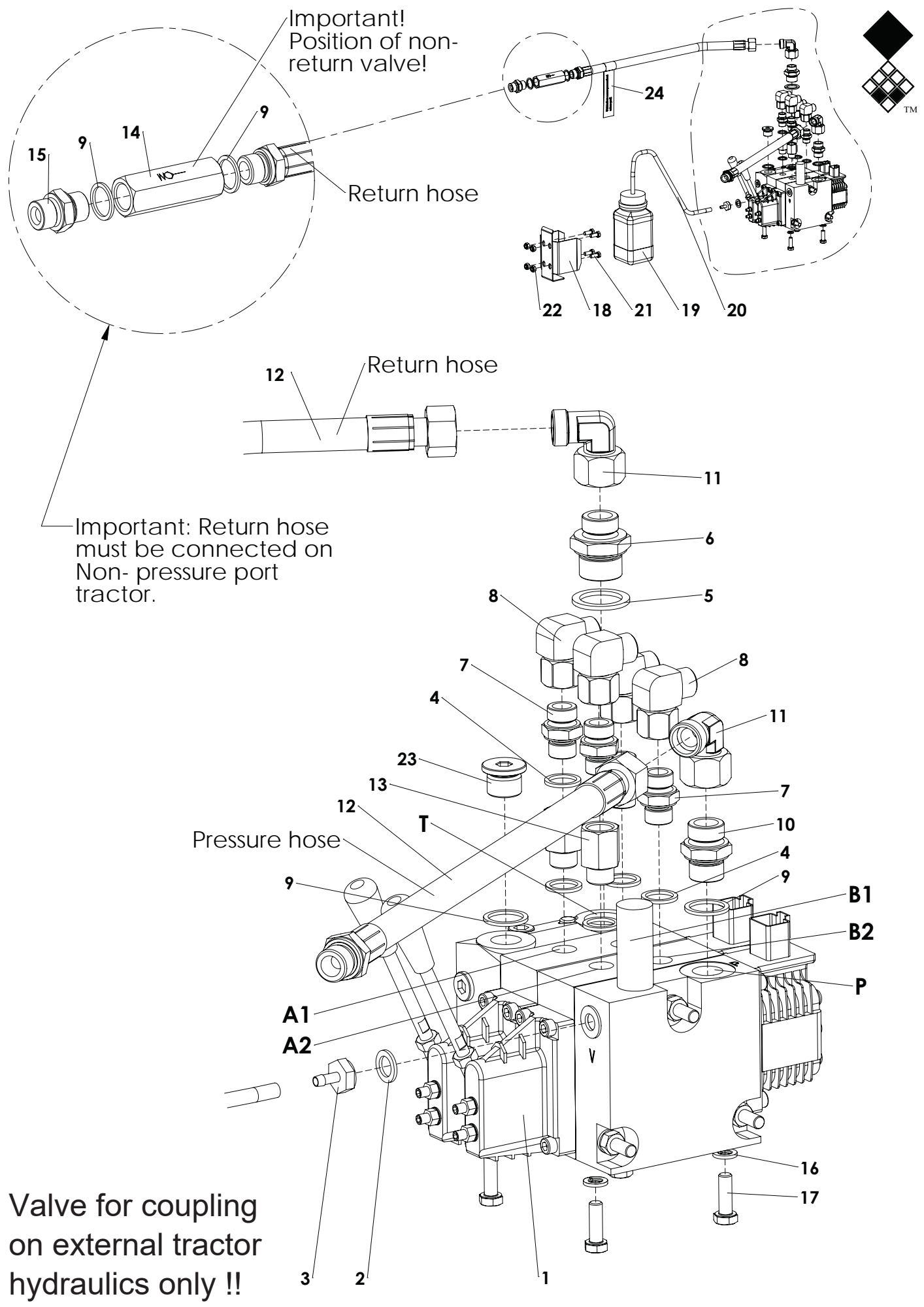

ITEM	PART NUMBER	DESCRIPTION	REMARKS	QUA
1	535.110.169	PVG16 Valve for tractor mounting		1
2	874.130.020	Copper washer 1/4"		2
3	549.060.190	Nipple		1
4	874.170.020	Copper washer 3_8		6
5	874.260.020	Copper washer 3/4"		1
6	544.260.222	Nipple pipe 3_4"x pipe 15 (M22)		1
7	544.170.120	Nipple BSP 3_8" x pipe 12 (M18)		4
8	544.123.180	L-Connector PM, Pipe 12-M18		4
9	874.210.020	Copper washer 1_2		4
10	544.210.150	Nipple BSP 1_2" x pipe 15 (M22)		1
11	544.151.150	L-Connector PM. Pipe 15-M22		2
12	541.192.000	Hose NSK13-1/2" TL=2500 PGLO1322 PN138		2
13	543.170.172	Extension nipple G3/8"xG3/8" L=23.5mm		2
14	536.210.800	SL Non-Return Valve 1/2", 0.5 bar		1
15	543.210.210	Nipple BSP 1_2" x 1_2" 60deg		1
16	866.080.020	Spring Washer M8 - DIN 127		4
17	804.080.250	Bolt M8 x 25 - ISO 4017		4
18	536.020.750	Oiltank holder		1
19	536.741.650	Oil tank 500 ml		1
20	536.097.000	Clear tube		1
21	804.100.250	Bolt M8 x 20 - ISO 4017		4
22	830.080.080	Self Lock Nut M8 - ISO 10511		4
23	549.210.200	Blind plug G1/2		1
24	922.340.001	Decal for return hose		1

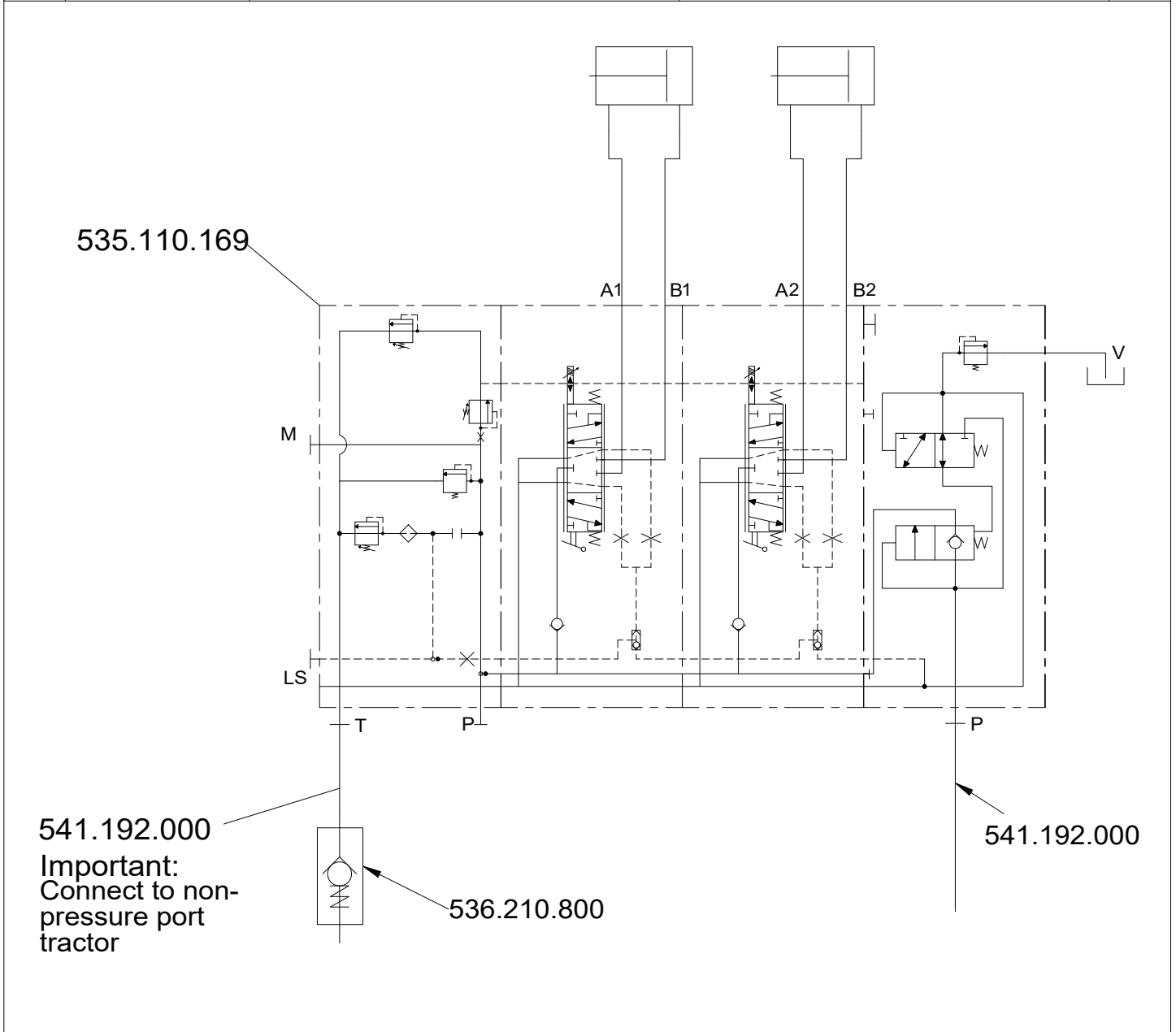

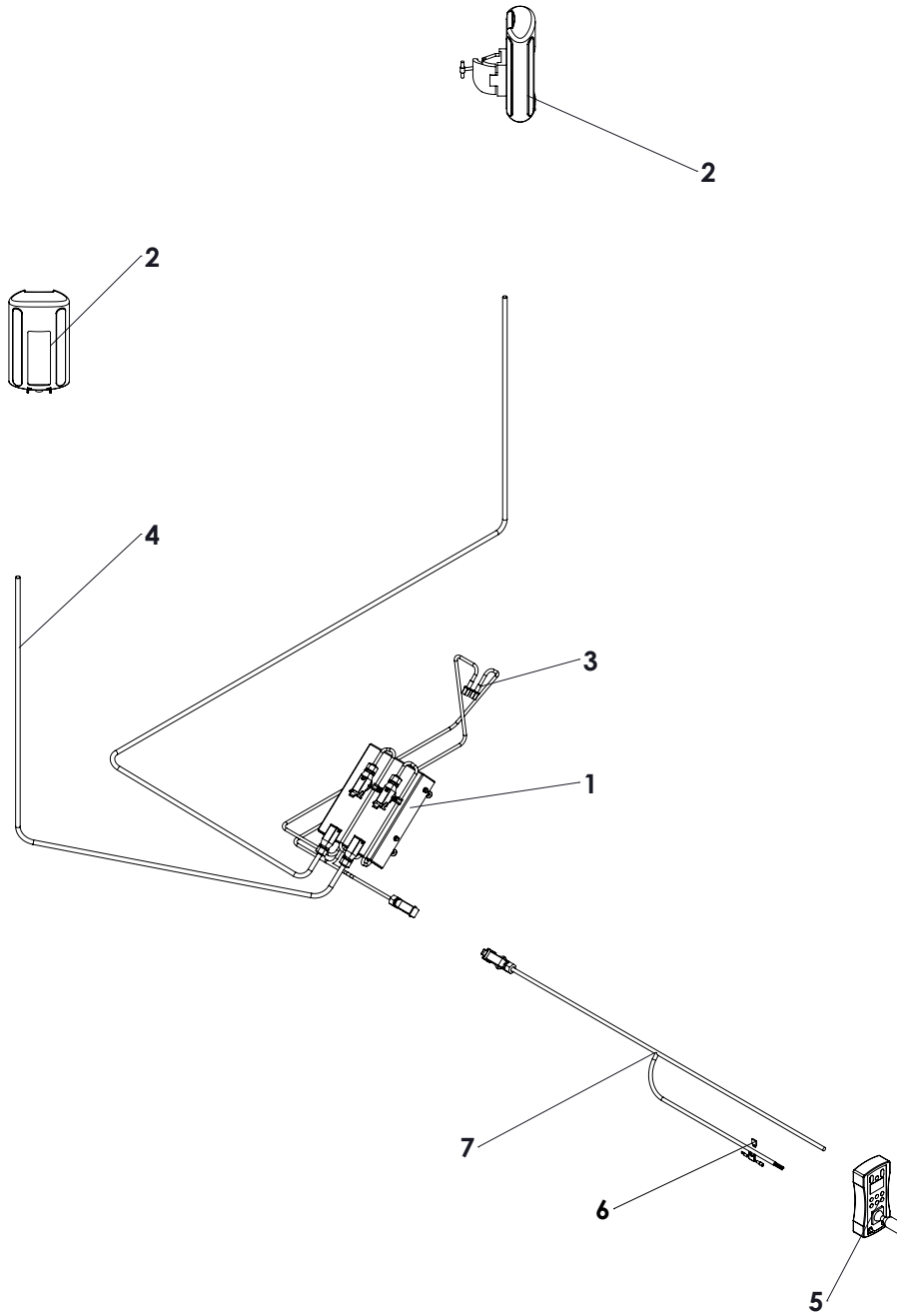

ITEM	PART NUMBER	DESCRIPTION	REMARKS	QUA Double	QUA Single
1		Laser control box	See page LK02	1	1
2	569.160.200	Trimble LR410		2	1
3	563.081.000	Valve wire		1	1
4	563.102.000 La	Laser wire		2	1
5	569.100.200	Control box laser		1	1
6	565.050.208	Fuse 10A		1	1
7	563.123.000	Tractor Wire		1	1
	191.180.003	Receivers and cantrole box dual pole kit	Page LK01 + LK02	1	0
	191.180.004	Receivers and cantrole box single pole kit	Page LK01 + LK02	0	1

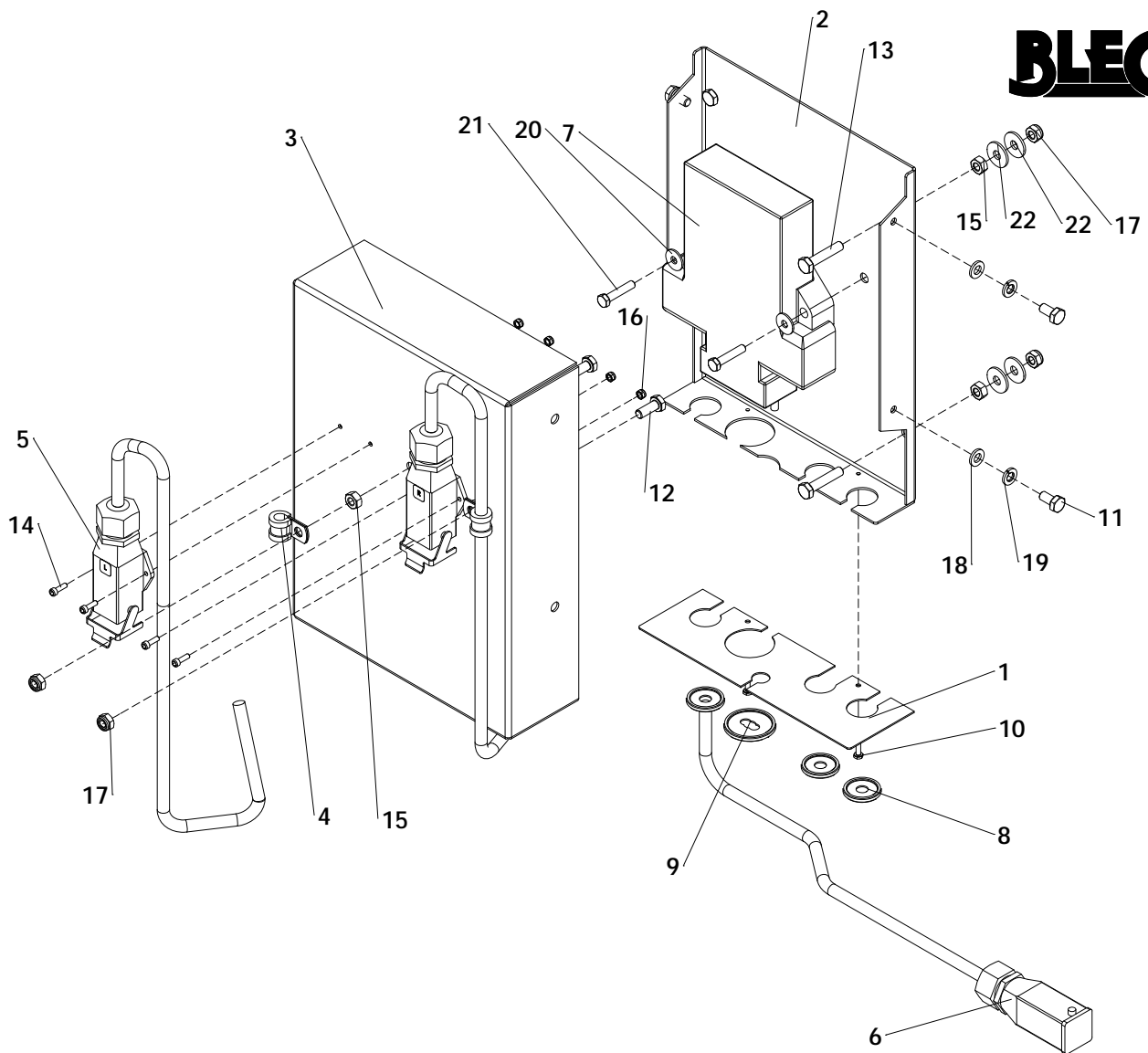

ITEM	PART NUMBER	DESCRIPTION	REMARKS	QUA Double	QUA Single
1	456.006.019	Cover		1	1
2	456.020.027	Rear cover		1	1
3	456.021.027	Front cover		1	1
4	547.080.160	Hose Clamp Ø8		2	1
5	563.080.300	Connector + wire		2	1
6	569.081.500	Connector female + wire		1	1
7	569.302.000	Computer laser kit		1	1
8	592.025.003	Hole cover		3	3
9	592.034.004	Hole cover		1	1
10	804.030.160	Bolt M3 x 16 - ISO 4017		2	2
11	804.060.120	Bolt M6 x 12 - ISO 4017		4	4
12	804.060.160	Bolt M6 x 16 - ISO 4017		2	1
13	804.060.300	Bolt M6 x 30 - ISO 4017		4	4
14	814.030.100	Bolt M3 x 10 - DIN 912		4	2
15	826.060.060	Nut M6 - DIN 934		6	5
16	830.030.030	Self Lock Nut M3 - ISO 10511		4	2
17	830.060.060	Self Lock Nut M6 - ISO 10511		6	5
18	864.060.030	Washer M6 - ISO 7089		4	4
19	866.060.020	Spring Washer M6 - DIN 127		4	4
20	864.050.031	Large washer M5 - DIN 9021		2	2
21	804.050.250	Bolt M5 x 25 - ISO 4017		2	2
22	864.060.031	Large washer M6 - DIN 9021		8	8

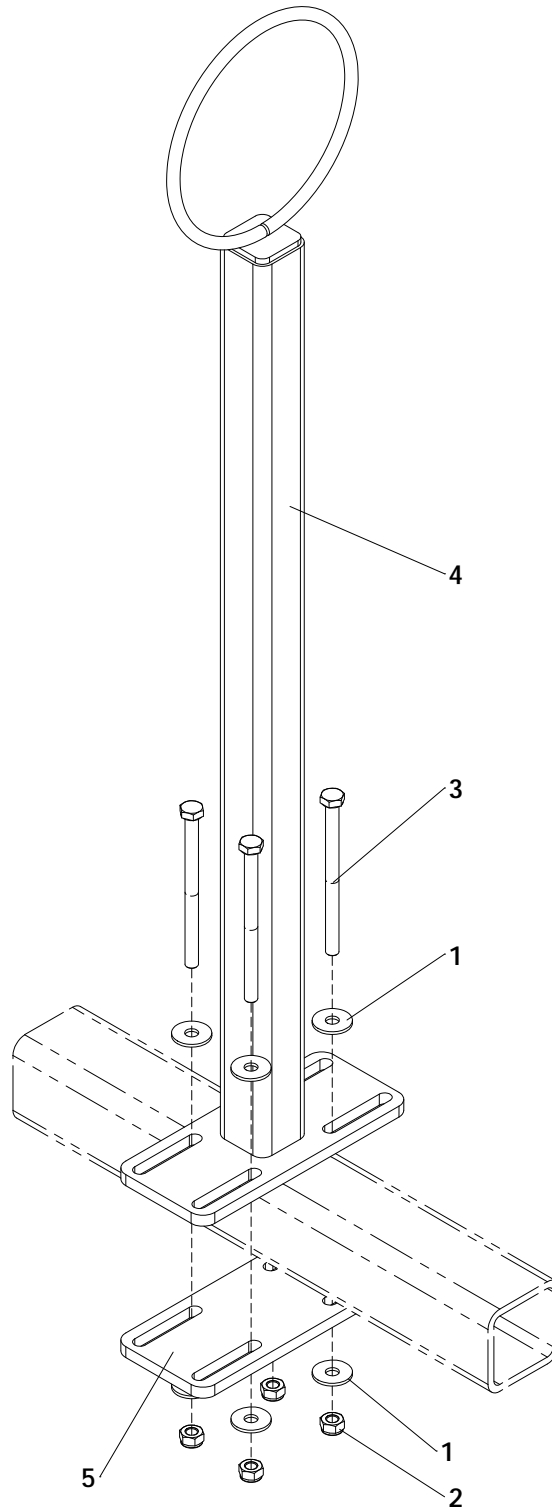
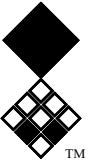

ITEM	PART NUMBER	DESCRIPTION	REMARKS	QUA
1	864.080.024	Large washer M8 - DIN 9021		8
2	830.080.080	Self Lock Nut M8 - ISO 10511		4
3	804.081.100	Bolt M8 x 110 - ISO 4017		4
4	462.820.075	Hose pole frame		1
5	468.081.752	Strip		1
	292.180.010	Hose pole	Parts 1 - 5	